

# FUNDAMENTALS OF 3D DESIGN AND SIMULATION

SOLIDWORKS EDUCATION EDITION 2023



# SOLIDWORKS® Education Edition 2023

## **Fundamentals of 3D Design and Simulation**

Dassault Systèmes SolidWorks Corporation  
175 Wyman Street  
Waltham, MA 02451 U.S.A.

© 1995-2023, Dassault Systemes SolidWorks Corporation, a Dassault Systèmes SE company, 175 Wyman Street, Waltham, Mass. 02451 USA. All Rights Reserved.

The information and the software discussed in this document are subject to change without notice and are not commitments by Dassault Systemes SolidWorks Corporation (DS SolidWorks).

No material may be reproduced or transmitted in any form or by any means, electronically or manually, for any purpose without the express written permission of DS SolidWorks.

The software discussed in this document is furnished under a license and may be used or copied only in accordance with the terms of the license. All warranties given by DS SolidWorks as to the software and documentation are set forth in the license agreement, and nothing stated in, or implied by, this document or its contents shall be considered or deemed a modification or amendment of any terms, including warranties, in the license agreement.

For a full list of the patents, trademarks, and third-party software contained in this release, please go to the Legal Notices in the SOLIDWORKS documentation.

## **Restricted Rights**

This clause applies to all acquisitions of Dassault Systèmes Offerings by or for the United States federal government, or by any prime contractor or subcontractor (at any tier) under any contract, grant, cooperative agreement or other activity with the federal government. The software, documentation and any other technical data provided hereunder is commercial in nature and developed solely at private expense. The Software is delivered as "Commercial Computer Software" as defined in DFARS 252.227-7014 (June 1995) or as a "Commercial Item" as defined in FAR 2.101(a) and as such is provided with only such rights as are provided in Dassault Systèmes standard commercial end user license agreement. Technical data is provided with limited rights only as provided in DFAR 252.227-7015 (Nov. 1995) or FAR 52.227-14 (June 1987), whichever is applicable. The terms and conditions of the Dassault Systèmes standard commercial end user license agreement shall pertain to the United States government's use and disclosure of this software, and shall supersede any conflicting contractual terms and conditions. If the DS standard commercial license fails to meet the United States government's needs or is inconsistent in any respect with United States Federal law, the United States government agrees to return this software, unused, to DS. The following additional statement applies only to acquisitions governed by DFARS Subpart 227.4 (October 1988): "Restricted Rights - use, duplication and disclosure by the Government is subject to restrictions as set forth in subparagraph (c)(1)(ii) of the Rights in Technical Data and Computer Software clause at DFARS 252-227-7013 (Oct. 1988)."

In the event that you receive a request from any agency of the U.S. Government to provide Software with rights beyond those set forth above, you will notify DS SolidWorks of the scope of the request and DS SolidWorks will have five (5) business days to, in its sole discretion, accept or reject such request. Contractor/ Manufacturer: Dassault Systemes SolidWorks Corporation, 175 Wyman Street, Waltham, Massachusetts 02451 USA.

# Contents

## Introduction

To the Teacher . . . . .	2
SOLIDWORKS Tutorials . . . . .	2
My SOLIDWORKS . . . . .	4
Certification Exams . . . . .	4
Training Files . . . . .	4
Educator Resources link . . . . .	4
Prerequisites . . . . .	5
Course Design Philosophy . . . . .	5
Conventions Used in this Book . . . . .	5
Windows . . . . .	5
Use of Color . . . . .	6
Graphics and Graphics Cards . . . . .	6
Color Schemes . . . . .	6

## Lesson 1: SOLIDWORKS Basics and the User Interface

What is the SOLIDWORKS Software? . . . . .	8
Design Intent . . . . .	10
Examples of Design Intent . . . . .	11
How Features Affect Design Intent . . . . .	11
File References . . . . .	12
Object Linking and Embedding (OLE) . . . . .	13
File Reference Example . . . . .	13
Opening Files . . . . .	14
Computer Memory . . . . .	14

The SOLIDWORKS User Interface . . . . . 15

    Welcome Dialog Box . . . . . 15

    Pull-down Menus . . . . . 16

Using the Command Manager . . . . . 16

    Adding and Removing CommandManager Tabs . . . . . 17

    FeatureManager Design Tree . . . . . 17

    PropertyManager . . . . . 19

    Full Path Name . . . . . 19

    Selection Breadcrumbs . . . . . 19

    Task Pane . . . . . 20

    Opening Labs with the File Explorer . . . . . 21

    Heads-up View Toolbar . . . . . 21

    Unselectable Icons . . . . . 21

    Mouse Buttons . . . . . 22

    Keyboard Shortcuts. . . . . 22

    Multiple Monitor Displays . . . . . 23

    System Feedback . . . . . 23

    Options . . . . . 24

    Search . . . . . 25

**Lesson 2:**  
**Introduction to Sketching**

2D Sketching. . . . . 28

Stages in the Process. . . . . 28

Saving Files. . . . . 30

    Save. . . . . 30

    Save As . . . . . 30

    Save As Copy to Disk. . . . . 30

    Save As Copy and Open . . . . . 30

What are We Going to Sketch? . . . . . 31

Sketching . . . . . 31

    Default Planes. . . . . 31

Sketch Entities . . . . . 33

    Sketch Geometry. . . . . 33

Basic Sketching. . . . . 34

    The Mechanics of Sketching. . . . . 34

    Inference Lines (Automatic Relations). . . . . 36

    Sketch Feedback . . . . . 37

    Status of a Sketch . . . . . 38

Rules That Govern Sketches. . . . . 38

Design Intent. . . . . 40

    What Controls Design Intent? . . . . . 40

    Desired Design Intent . . . . . 41

Sketch Relations . . . . .	41
Automatic Sketch Relations . . . . .	41
Added Sketch Relations . . . . .	42
Examples of Sketch Relations . . . . .	43
Selecting Multiple Objects . . . . .	45
Dimensions . . . . .	46
Dimensioning: Selection and Preview . . . . .	47
Angular Dimensions . . . . .	50
Instant 2D . . . . .	51
Extrude . . . . .	51
Sketching Guidelines† . . . . .	54
Exercise 1: Sketch and Extrude 1 . . . . .	55
Exercise 2: Sketch and Extrude 2 . . . . .	56
Exercise 3: Sketch and Extrude 3 . . . . .	57
Exercise 4: Sketch and Extrude 4 . . . . .	58
Exercise 5: Sketch and Extrude 5 . . . . .	59
Exercise 6: Sketch and Extrude 6 . . . . .	60

### **Lesson 3: Basic Part Modeling**

Basic Modeling . . . . .	62
Stages in the Process . . . . .	62
Terminology . . . . .	63
Feature . . . . .	63
Plane . . . . .	63
Extrusion . . . . .	63
Sketch . . . . .	63
Boss . . . . .	63
Cut . . . . .	63
Fillet and Rounds . . . . .	63
Design Intent . . . . .	63
Choosing the Best Profile . . . . .	64
Choosing the Sketch Plane . . . . .	65
Planes . . . . .	65
Placement of the Model . . . . .	65
Details of the Part . . . . .	67
Standard Views . . . . .	67
Main Bosses . . . . .	67
Best Profile . . . . .	67
Sketch Plane . . . . .	68
Design Intent . . . . .	68
Sketching the First Feature . . . . .	69
Extrude Options . . . . .	70
Renaming Features . . . . .	70

Boss Feature . . . . .	71
Sketching on a Planar Face . . . . .	71
Sketching . . . . .	71
Tangent Arc Intent Zones . . . . .	72
Autotransitioning Between Lines and Arcs . . . . .	72
Cut Feature . . . . .	74
View Selector . . . . .	75
Using the Hole Wizard . . . . .	76
Creating a Standard Hole . . . . .	76
Counterbore Hole . . . . .	76
Filleting . . . . .	78
Filleting Rules . . . . .	78
Editing Tools . . . . .	81
Editing a Sketch . . . . .	81
Selecting Multiple Objects . . . . .	81
Editing Features . . . . .	82
Fillet Propagation . . . . .	82
Rollback Bar . . . . .	82
Detailing Basics . . . . .	87
Settings Used in the Template . . . . .	88
CommandManager Tabs . . . . .	88
New Drawing . . . . .	88
Drawing Views . . . . .	89
Tangent Edges . . . . .	91
Moving Views . . . . .	92
Center Marks . . . . .	93
Dimensioning . . . . .	94
Driving Dimensions . . . . .	94
Driven Dimensions . . . . .	94
Manipulating Dimensions . . . . .	96
Associativity Between the Model and the Drawing . . . . .	99
Changing Parameters . . . . .	99
Rebuilding the Model . . . . .	99
Exercise 7: Plate . . . . .	102
Exercise 8: Cuts . . . . .	104
Exercise 9: Basic-Changes . . . . .	107
Exercise 10: Base Bracket . . . . .	109
Exercise 11: Part Drawings . . . . .	113

## Lesson 4: Patterning

Why Use Patterns? .....	116
Pattern Options .....	120
Linear Pattern .....	121
Flyout FeatureManager Design Tree .....	122
Skipping Instances .....	123
Geometry Patterns .....	124
Performance Evaluation .....	125
Circular Patterns .....	127
Reference Geometry .....	128
Axes .....	128
Planes .....	130
Mirror Patterns .....	135
Patterning a Solid Body .....	137
Using Pattern Seed Only .....	138
Up To Reference .....	139
Sketch Driven Patterns .....	142
Points .....	143
Automatic Dimensioning of Sketches .....	144
Exercise 12: Linear Patterns .....	148
Exercise 13: Sketch Driven Patterns .....	149
Exercise 14: Skipping Instances .....	150
Exercise 15: Linear and Mirror Patterns .....	151
Exercise 16: Mirror Body .....	152
Exercise 17: Circular Patterns .....	153
Exercise 18: Axes and Multiple Patterns .....	154

## Lesson 5: Revolved Features

Case Study: Handwheel .....	158
Stages in the Process .....	158
Design Intent .....	159
Revolved Features .....	159
Sketch Geometry of the Revolved Feature .....	159
Rules Governing Sketches of Revolved Features .....	161
Special Dimensioning Techniques .....	161
Diameter Dimensions .....	162
Creating the Revolved Feature .....	163

Building the Rim . . . . .	165
Slots . . . . .	165
Multibody Solids . . . . .	168
Building the Spoke . . . . .	168
Edge Selection . . . . .	173
Chamfers . . . . .	175
RealView Graphics . . . . .	175
Edit Material . . . . .	178
Mass Properties . . . . .	181
Mass Properties as Custom Properties . . . . .	182
File Properties . . . . .	182
Classes of File Properties . . . . .	182
Creating File Properties . . . . .	183
Uses of File Properties . . . . .	183
SOLIDWORKS SimulationXpress . . . . .	185
Overview . . . . .	185
Mesh . . . . .	185
Using SOLIDWORKS SimulationXpress . . . . .	186
The SimulationXpress Interface . . . . .	187
Options . . . . .	187
Phase 1: Fixtures . . . . .	188
Phase 2: Loads . . . . .	189
Phase 3: Material . . . . .	189
Phase 4: Run . . . . .	190
Phase 5: Results . . . . .	190
Phase 6: Optimize . . . . .	191
Updating the Model . . . . .	192
Results, Reports and eDrawings . . . . .	193
Exercise 19: Flange . . . . .	195
Exercise 20: Wheel . . . . .	196
Exercise 21: Guide . . . . .	199
Exercise 22: Ellipse . . . . .	203
Exercise 23: Sweeps . . . . .	204
Slide Stop . . . . .	204
Cotter Pin . . . . .	204
Paper Clip . . . . .	205
Mitered Sweep . . . . .	205
Exercise 24: SimulationXpress . . . . .	206

**Lesson 6:****Bottom-Up Assembly Modeling**

Case Study: Universal Joint . . . . .	210
Bottom-Up Assembly . . . . .	210
Stages in the Process. . . . .	210
The Assembly . . . . .	211
Creating a New Assembly. . . . .	212
Position of the First Component. . . . .	213
FeatureManager Design Tree and Symbols . . . . .	214
Degrees of Freedom . . . . .	214
Components . . . . .	214
Component Name . . . . .	214
State of the component . . . . .	215
Adding Components . . . . .	217
Insert Component . . . . .	217
Moving and Rotating Components. . . . .	218
Mating Components . . . . .	219
Mate Types and Alignment. . . . .	220
Mating Concentric and Coincident. . . . .	223
Width Mate . . . . .	228
Rotating Inserted Components . . . . .	231
Using the Component Preview Window . . . . .	232
Parallel Mate. . . . .	233
Dynamic Assembly Motion . . . . .	234
Displaying Part Configurations in an Assembly. . . . .	234
The Pin . . . . .	235
Using Part Configurations in Assemblies . . . . .	235
The Second Pin . . . . .	237
Opening a Component . . . . .	237
Creating Copies of Instances . . . . .	239
Component Hiding and Transparency . . . . .	240
Component Properties. . . . .	242
Subassemblies. . . . .	243
Smart Mates . . . . .	244
Inserting Subassemblies . . . . .	246
Mating Subassemblies . . . . .	247
Distance Mates . . . . .	248
Unit System. . . . .	248
Pack and Go . . . . .	250
Exercise 25: Mates . . . . .	251
Exercise 26: Gripe Grinder. . . . .	253
Exercise 27: Using Hide and Show Component. . . . .	255
Exercise 28: Part Configurations in an Assembly . . . . .	257
Exercise 29: U-Joint Changes. . . . .	259

## Lesson 7: The Analysis Process

Objectives . . . . .	261
The Analysis Process . . . . .	262
Stages in the Process. . . . .	262
Case Study: Stress in a Plate. . . . .	262
Project Description . . . . .	263
SOLIDWORKS Simulation Interface . . . . .	264
SOLIDWORKS Simulation Options . . . . .	266
Plot Settings . . . . .	267
Preprocessing . . . . .	269
New Study. . . . .	269
Assigning Material Properties . . . . .	270
Fixtures . . . . .	272
Fixture Types . . . . .	272
External Loads . . . . .	275
Size and Color of Symbols . . . . .	278
Preprocessing Summary . . . . .	279
Meshing . . . . .	280
Standard Mesh . . . . .	280
Curvature-Based Mesh . . . . .	280
Blended Curvature-Based Mesh . . . . .	280
Mesh Density . . . . .	281
Element Sizes . . . . .	281
Minimum Number of Elements in a Circle . . . . .	281
Ratio . . . . .	282
Mesh Quality. . . . .	283
Processing . . . . .	285
Postprocessing . . . . .	285
Result Plots . . . . .	285
Modifying Result Plots . . . . .	286
Nodal vs. Element Stresses. . . . .	287
Show as Tensor Plot Option . . . . .	288
Average stresses at mid-nodes . . . . .	289
Managing Result Plots . . . . .	293
Additional Plot Controls . . . . .	293
Other Plots . . . . .	297
Multiple Studies . . . . .	300
Creating New Studies . . . . .	300
Copy Parameters . . . . .	300
Check Convergence and Accuracy . . . . .	303
Results Summary . . . . .	303
Comparison with Analytical Results . . . . .	305

Reports .....	306
Summary .....	308
References .....	308
Questions .....	308
Exercise 30: Bracket .....	309
Exercise 31: Compressive Spring Stiffness .....	318
Problem Statement .....	318
Exercise 32: Container Handle .....	321

**Lesson 8:****Introduction to Motion Simulation and Forces**

Objectives .....	323
Basic Motion Analysis .....	324
Case Study: Car Jack Analysis .....	324
Problem Description .....	324
Stages in the Process .....	325
Driving Motion .....	328
Gravity .....	330
Forces .....	331
Understanding Forces .....	331
Applied Forces .....	331
Force Definition .....	331
Force Direction .....	332
Case 1 .....	332
Case 2 .....	332
Case 3 .....	333
Results .....	335
Plot Categories .....	335
Sub-Categories .....	335
Resizing Plots .....	335
Exercise 33: 3D Fourbar Linkage .....	342

## Lesson 9: Creating a SOLIDWORKS Flow Simulation Project

Objectives . . . . .	345
Case Study: Manifold Assembly . . . . .	346
Problem Description . . . . .	346
Stages in the Process . . . . .	346
Model Preparation . . . . .	347
Internal Flow Analysis . . . . .	347
External Flow Analysis . . . . .	347
Manifold Analysis . . . . .	348
Lids . . . . .	348
Lid Thickness . . . . .	349
Manual Lid Creation . . . . .	349
Adding a Lid to a Part File . . . . .	349
Adding a Lid to an Assembly File . . . . .	350
Checking the Geometry . . . . .	352
Internal Fluid Volume . . . . .	353
Invalid Contacts . . . . .	353
Project Wizard . . . . .	358
Dependency . . . . .	361
Exclude Cavities Without Flow Conditions . . . . .	361
Adiabatic Wall . . . . .	362
Roughness . . . . .	362
Computational Domain . . . . .	364
Mesh . . . . .	371
Load Results Option . . . . .	371
Monitoring the Solver . . . . .	372
Goal Plot Window . . . . .	373
Warning Messages . . . . .	373
Post-processing . . . . .	376
Scaling the Limits of the Legend . . . . .	378
Changing Legend Settings . . . . .	378
Orientation of the Legend, Logarithmic Scale . . . . .	378
Discussion . . . . .	391
Summary . . . . .	391

# Introduction

## To the Teacher

The *SOLIDWORKS Education Edition - Fundamentals of 3D Design and Simulation* manual is designed to assist you in teaching SOLIDWORKS and SOLIDWORKS Simulation in an academic setting. This guide offers a competency-based approach to teaching 3D design concepts, analysis and techniques.

Qualified schools on subscription have access to the eBook at no cost to students. Contact your SOLIDWORKS Value Added Reseller to obtain access.

## SOLIDWORKS Tutorials

The *SOLIDWORKS Education Edition - Fundamentals of 3D Design and Simulation* manual also supplements the SOLIDWORKS Tutorials.



## Accessing the SOLIDWORKS Tutorials

To start the SOLIDWORKS Tutorials, click **Help, SOLIDWORKS Tutorials**. The SOLIDWORKS window is resized and a second window appears next to it with a list of the available tutorials. There are over 40 lessons in the SOLIDWORKS Tutorials. As you move the pointer over the links, an illustration of the tutorial will appear at the bottom of the window. Click the desired link to start that tutorial.

---

**TIP:** When you use SOLIDWORKS Simulation to perform analysis, click **Help, SOLIDWORKS Simulation, Tutorials** to access over 50 lessons and over 80 verification problems. Click **Tools, Add-ins** to activate SOLIDWORKS Simulation, SOLIDWORKS Motion, and SOLIDWORKS Flow Simulation.

---

## Conventions

Set your screen resolution to 1280x1024 for optimal viewing of the tutorials.

The following icons appear in the tutorials:

 Moves to the next screen in the tutorial.

 Represents a note or tip. It is not a link; the information is below the icon. Notes and tips provide time-saving steps and helpful hints.

 You can click most buttons that appear in the lessons to flash the corresponding SOLIDWORKS button.

 **Open File** or **Set this option** automatically opens the file or sets the option.

 **A closer look at...** links to more information about a topic. Although not required to complete the tutorial, it offers more detail on the subject.

 **Why did I...** links to more information about a procedure, and the reasons for the method given. This information is not required to complete the tutorial.

 **Show me...** demonstrates with a video.

## Printing the SOLIDWORKS Tutorials

If you like, you can print the SOLIDWORKS Tutorials by following this procedure:

1. On the tutorial navigation toolbar, click **Show**.  
This displays the table of contents for the SOLIDWORKS Tutorials.
2. Right-click the book representing the lesson you wish to print and select **Print...** from the shortcut menu.  
The **Print Topics** dialog box appears.
3. Select **Print the selected heading and all subtopics**, and click **OK**.
4. Repeat this process for each lesson that you want to print.

## My SOLIDWORKS

My.SolidWorks.com is a community website to share, connect, and learn everything about SOLIDWORKS. My SOLIDWORKS learning contains additional video lessons and individual learning paths for your students.

## Certification Exams

The Certified SOLIDWORKS Associate(CSWA) - Academic program provides free certification exams for you or your students in a proctored setting. Achieving CSWA proves the fundamentals of engineering design competency. Employers verify students job ready credentials through our online virtual tester. Schools that provide two or more courses in SOLIDWORKS-based instruction can also apply to be a Certified SOLIDWORKS Professional(CSWP) - Academic Provider.

More information and to apply can be found at [www.solidworks.com/cswa-academic](http://www.solidworks.com/cswa-academic).

## Training Files

A complete set of the various files used throughout the course can be downloaded from the following website:

[www.solidworks.com/EDU\\_Fundamentals3DDesignSim](http://www.solidworks.com/EDU_Fundamentals3DDesignSim)

The files are organized by lesson number. The Case Study folder within each lesson contains the files you need when presenting the lessons. The Exercises folder contains any files that are required for doing the laboratory exercises.

## Educator Resources link

The **Instructors Curriculum** link on the **SOLIDWORKS Resources**  tab of the Task Pane includes substantial supporting materials to aid in your course presentation. Accessing this page requires a login account for the SOLIDWORKS Customer Portal. These supporting materials afford you flexibility in scope, depth, and presentation.

1. Start SOLIDWORKS.

Using the **Start** menu, start the SOLIDWORKS application.

2. SOLIDWORKS Content.

Click **SOLIDWORKS Resources**  to open the SOLIDWORKS Resources Task Pane.

Click on the **Instructors Curriculum** link which will take you to the SOLIDWORKS Customer Portal web page.

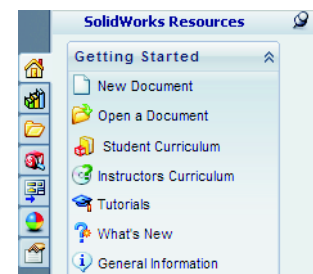

**Prerequisites**

Students attending this course are expected to have the following:

- Mechanical design experience.
- Experience with the Windows<sup>®</sup> operating system.
- Completed the online tutorials that are integrated in the SOLIDWORKS software. You can access the online tutorials by clicking **Help, Online Tutorial**.

**Course Design Philosophy**

This course is designed around a process- or task-based approach to training. A process-based training course emphasizes the processes and procedures you follow to complete a particular task. By utilizing case studies to illustrate these processes, you learn the necessary commands, options and menus in the context of completing a task.

**A Note About Dimensions**

The drawings and dimensions given in the lab exercises are not intended to reflect any particular drafting standard. In fact, sometimes dimensions are given in a fashion that would never be considered acceptable in industry. The reason for this is the labs are designed to encourage you to apply the information covered in class and to employ and reinforce certain techniques in modeling. As a result, the drawings and dimensions in the exercises are done in a way that complements this objective.

**Conventions Used in this Book**

This manual uses the following typographic conventions:

Convention	Meaning
<b>Bold Sans Serif</b>	SOLIDWORKS commands and options appear in this style. For example, <b>Features &gt; Extruded Cut</b>  means click the <b>Extruded Cut</b> icon on the <b>Features</b> tab of the CommandManager.
Typewriter	Feature names and file names appear in this style. For example, Sketch1.
<b>17 Do this step</b>	Double lines precede and follow sections of the procedures. This provides separation between the steps of the procedure and large blocks of explanatory text. The steps themselves are numbered in sans serif bold.

**Windows**

The screen shots in this manual were made using the SOLIDWORKS software running a mixture of Windows<sup>®</sup> 7 and Windows 10. You may notice slight differences in the appearance of the menus and windows. These differences do not affect the performance of the software.

## Use of Color

The SOLIDWORKS user interface makes extensive use of color to highlight selected geometry and to provide you with visual feedback. This greatly increases the intuitiveness and ease of use of the SOLIDWORKS software. To take maximum advantage of this, the training manuals are printed in full color.

Also, in many cases, we have used additional color in the illustrations to communicate concepts, identify features, and otherwise convey important information. For example, we might show the result of a filleting operation with the fillets in a different color even though, by default, the SOLIDWORKS software would not display the results in that way.

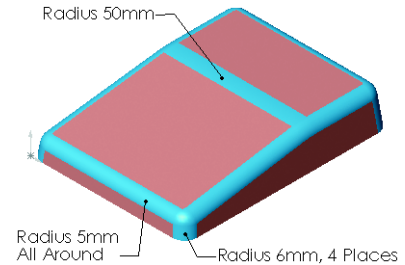

## Graphics and Graphics Cards

The SOLIDWORKS software sets a new standard with best-in-class graphics. The combination of a highly reflective material and the realism of **RealView Graphics** is an effective tool for evaluating the quality of advanced part models and surfaces.

**RealView Graphics** is hardware (graphics card) support of advanced shading in real time. For example, if you rotate a part, it retains its rendered appearance throughout the rotation.



## Color Schemes

Out of the box, the SOLIDWORKS software provides several predefined color schemes that control, among other things, the colors used for highlighted items, selected items, sketch relation symbols, and shaded previews of features.

We have not used the same color scheme for every case study and exercise because some colors are more visible and clear than others when used with different colored parts.

In addition, we have changed the viewport background to plain white so that the illustrations reproduce better on white paper.

As a result, because the color settings on your computer may be different than the ones used by the authors of this book, the images you see on your screen may not exactly match those in the book.

## User Interface Appearance

Throughout the development of the software, there have been some cosmetic User Interface changes, intended to improve visibility, that do not affect the function of the software. As a policy, dialog images in the manuals which exhibit no functional change from the previous version are not replaced. As such, you may see a mixture of current and “old” UI dialogs and color schemes.

# Lesson 1

## SOLIDWORKS Basics and the User Interface

Upon successful completion of this lesson, you will be able to:

- Describe the key characteristics of a feature-based, parametric solid modeler.
- Distinguish between sketched and applied features.
- Identify the principal components of the SOLIDWORKS user interface.
- Explain how different dimensioning methodologies convey different design intents.

## What is the SOLIDWORKS Software?

SOLIDWORKS mechanical design automation software is a *feature-based, parametric solid modeling* design tool which takes advantage of the easy to learn Windows graphical user interface. You can create *fully associative* 3D solid models with or without *constraints* while utilizing automatic or user defined relations to capture *design intent*.

The italicized terms in the previous paragraph mean:

### ■ Feature-based

Just as an assembly is made up of a number of individual piece parts, a SOLIDWORKS model is also made up of individual constituent elements. These elements are called features.

When you create a model using the SOLIDWORKS software, you work with intelligent, easy to understand geometric features such as bosses, cuts, holes, ribs, fillets, chamfers, and drafts. As the features are created they are applied directly to the work piece.

Features can be classified as either sketched or applied.

- **Sketched Features:** Based upon a 2D sketch. Generally that sketch is transformed into a solid by extrusion, rotation, sweeping or lofting.
- **Applied Features:** Created directly on the solid model. Fillets and chamfers are examples of this type of feature.

The SOLIDWORKS software graphically shows you the feature-based structure of your model in a special window called the FeatureManager® design tree. The FeatureManager design tree not only shows you the sequence in which the features were created, it gives you easy access to all the underlying associated information. You will learn more about the FeatureManager design tree throughout this course.

To illustrate the concept of feature-based modeling, consider the part shown at the right:

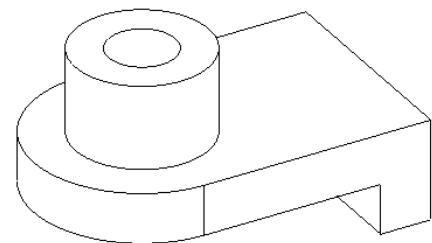

This part can be visualized as a collection of several different features – some of which add material, like the cylindrical boss, and some which remove material, like the blind hole.

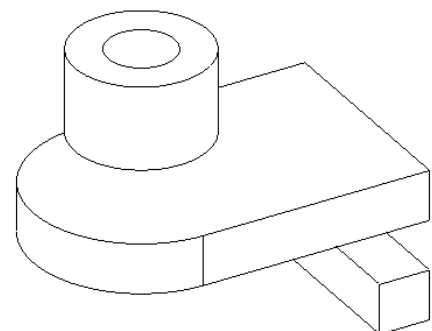

If we were to map the individual features to their corresponding listing in the FeatureManager design tree, it would look like this:

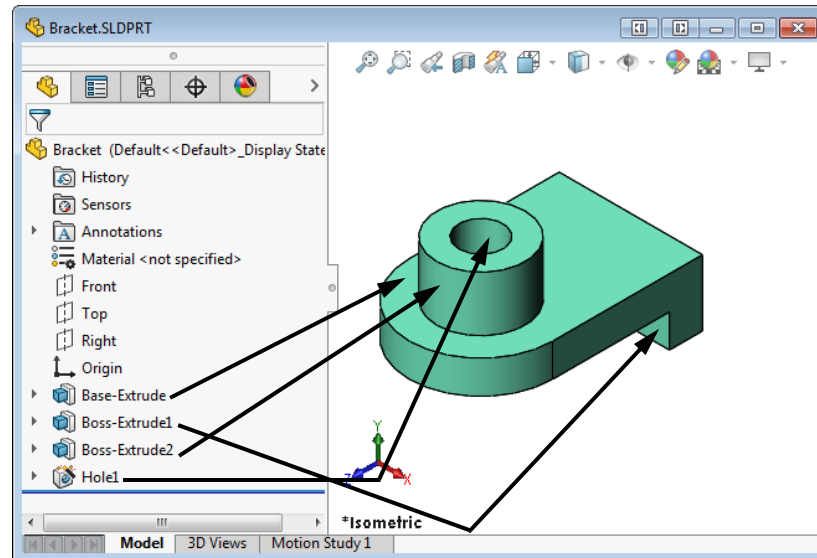

### ■ Parametric

The dimensions and relations used to create a feature are captured and stored in the model. This not only enables you to capture your design intent, it also enables you to quickly and easily make changes to the model.

- **Driving Dimensions:** These are the dimensions used when creating a feature. They include the dimensions associated with the sketch geometry, as well as those associated with the feature itself. A simple example of this would be a feature like a cylindrical boss. The diameter of the boss is controlled by the diameter of the sketched circle. The height of the boss is controlled by the depth to which that circle was extruded when the feature was made.
- **Relations:** These include such information as parallelism, tangency, and concentricity. Historically, this type of information has been communicated on drawings via feature control symbols. By capturing this in the sketch, SOLIDWORKS enables you to fully capture your design intent up front, in the model.

### ■ Solid Modeling

A solid model is the most complete type of geometric model used in CAD systems. It contains all the wire frame and surface geometry necessary to fully describe the edges and faces of the model. In addition to the geometric information, it has the information called topology that relates the geometry together. An example of topology would be which faces (surfaces) meet at which edge (curve). This intelligence makes operations such as filleting as easy as selecting an edge and specifying a radius.

- **Fully Associative**  
A SOLIDWORKS model is fully associative to the drawings and assemblies that reference it. Changes to the model are automatically reflected in the associated drawings and assemblies. Likewise, you can make changes in the context of the drawing or assembly and know that those changes will be reflected back in the model.
- **Constraints**  
Geometric relationships such as parallel, perpendicular, horizontal, vertical, concentric, and coincident are just some of the constraints supported in SOLIDWORKS. In addition, equations can be used to establish mathematical relationships among parameters. By using constraints and equations, you can guarantee that design concepts such as through holes or equal radii are captured and maintained.
- **Design Intent**  
The final italicized term is design intent. This subject is worthy of its own section, as follows.

## Design Intent

In order to use a parametric modeler like SOLIDWORKS efficiently, you must consider the design intent before modeling. Design intent is your plan as to how the model should behave when it is changed. The way in which the model is created governs how it will be changed. Several factors contribute to how you capture design intent:

- **Automatic (sketch) Relations**  
Based on how geometry is sketched, these relations can provide common geometric relationships between objects such as parallel, perpendicular, horizontal, and vertical.
- **Equations**  
Used to relate dimensions algebraically, they provide an external way to force changes.
- **Added Relations**  
Added to the model as it is created, relations provide another way to connect related geometry. Some common relations are concentric, tangent, coincident, and collinear.
- **Dimensioning**  
Consider your design intent when applying dimensions to a sketch. What are the dimensions that should drive the design? What values are known? Which are important for the production of the model? The way dimensions are applied to the model will determine how the geometry will change if modifications are made.

Consider the design intent in the following examples.

### Examples of Design Intent

The design intent of each sketch below is slightly different. How will the geometry be affected if the overall plate width, **100mm**, is changed?

A sketch dimensioned like this will keep the holes **20mm** from each end regardless of the width of the plate.

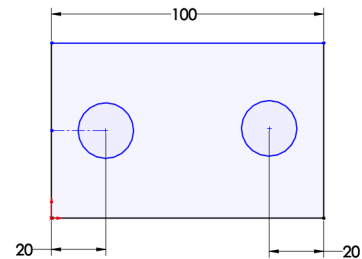

Baseline dimensions like this will keep the holes positioned relative to the left edge of the plate. The positions of the holes are not affected by changes in the overall width of the plate.

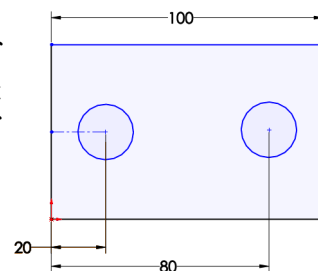

Dimensioning from the edge and from center to center will maintain the distance between the hole centers and allow it to be changed that way.

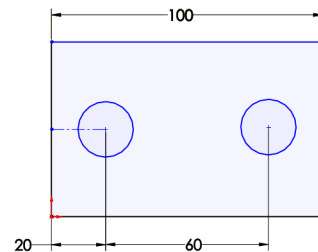

### How Features Affect Design Intent

Design intent is affected by more than just how a sketch is dimensioned. The choice of features and the modeling methodology are also important. For example, consider the case of a simple stepped shaft as shown at the right. There are several ways a part like this could be built and each way creates a part that is geometrically identical.

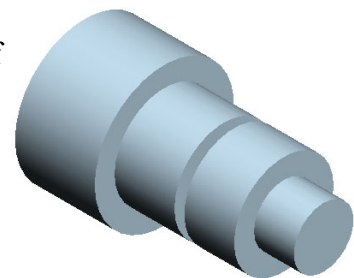

### The “Layer Cake” Approach

The layer cake approach builds the part one piece at a time, adding each layer, or feature, onto the previous one, like this:

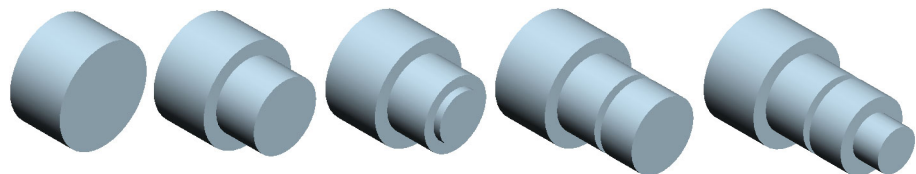

Changing the thickness of one layer has a ripple effect, changing the position of all the other layers that were created after it.

### The “Potter’s Wheel” Approach

The potter’s wheel approach builds the part as a single, revolved feature. A single sketch representing the cross section includes all the information and dimensions necessary to make the part as one feature. While this approach may seem very efficient, having all the design information contained within a single feature limits flexibility and can make changes awkward.

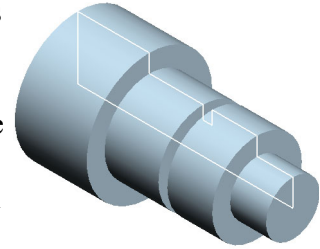

### The Manufacturing Approach

The manufacturing approach to modeling mimics the way the part would be manufactured. For example, if this stepped shaft was turned on a lathe, you would start with a piece of bar stock and remove material using a series of cuts.

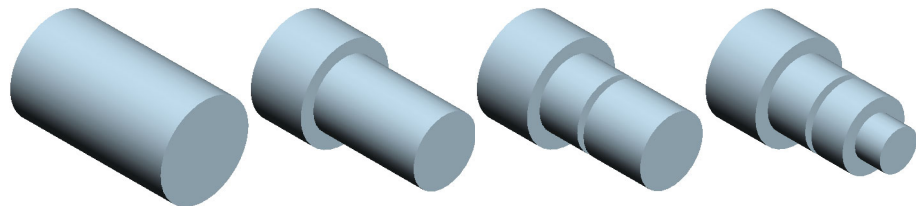

There is not really a right or wrong answer when trying to determine which approach to use. SOLIDWORKS allows for great flexibility and making changes to models is relatively easy. But creating models with design intent in mind will result in well built documents that are easily modifiable and well suited for re-use, making your job easier.

### File References

SOLIDWORKS creates files that are compound documents that contain elements from other files. File references are created by linking files rather than duplicating information in multiple files.

Referenced files do not have to be stored with the document that references them. In most practical applications, the referenced documents are stored in multiple locations on the computer or network. SOLIDWORKS provides several tools to determine the references that exist and their location.

**Object Linking and Embedding (OLE)**

In the Windows environment, information sharing between files can be handled either by linking or embedding the information.

The main differences between linked objects and embedded objects are where the data is stored and how you update the data after you place it in the destination file.

**Linked Objects**

When an object is linked, information is updated only if the source file is modified. Linked data is stored in the source file. The destination file stores only the location of the source file (an external reference), and it displays a representation of the linked data.

Linking is also useful when you want to include information that is maintained independently, such as data collected by a different department.

**Embedded Objects**

When you embed an object, information in the destination file doesn't change if you modify the source file. Embedded objects become part of the destination file and, once inserted, are no longer part of the source file.

**File Reference Example**

The many different types of external references created by SOLIDWORKS are shown in the following graphic. Some of the references can be linked or embedded.

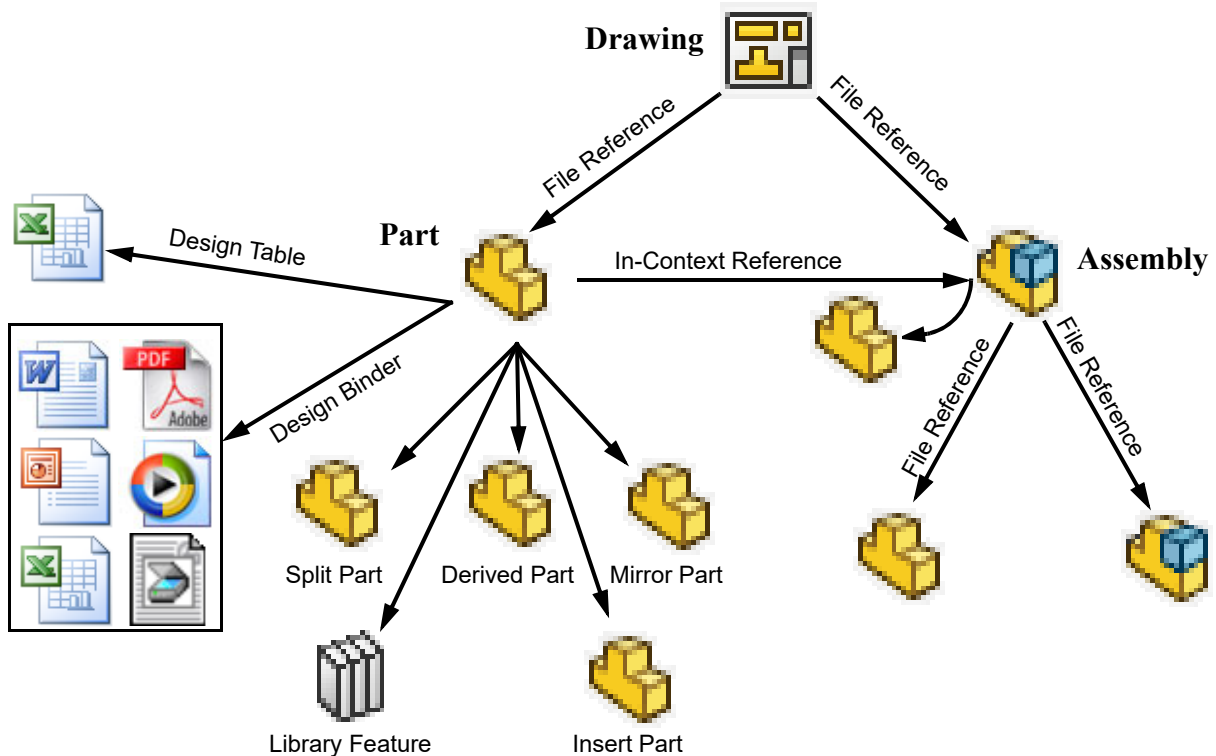

## Opening Files

SOLIDWORKS is a RAM-resident CAD system. Whenever a file is opened, it is copied from its storage location to the computer's Random Access Memory or RAM. All changes to the file are made to the copy in RAM and only written back to the original files during a **Save** operation.

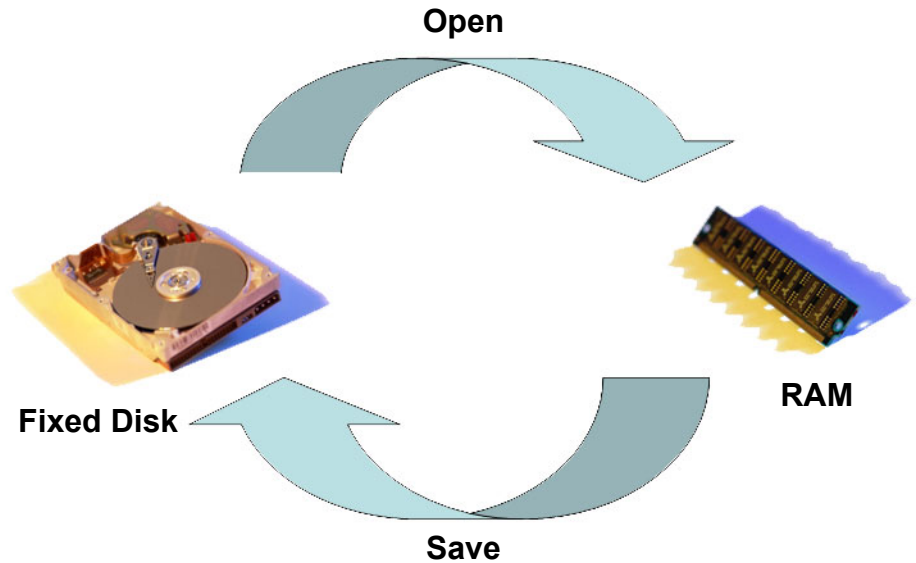

### Computer Memory

To better understand where files are stored and which copy of the file we are working on, it is important to differentiate between the two main types of computer memory.

#### Random Access Memory

Random Access Memory (RAM) is the volatile memory of the computer. This memory only stores information when the computer is operating. When the computer is turned off, any information in RAM is lost.

#### Fixed Memory

Fixed memory is all the non-volatile memory. This includes computer hard drives, flash drives and CD/DVD drives. Fixed memory holds its information even when the computer is not running.

# The SOLIDWORKS User Interface

The SOLIDWORKS user interface is a native Windows interface, and as such behaves in the same manner as other Windows applications. Some of the more important aspects of the interface are identified below.

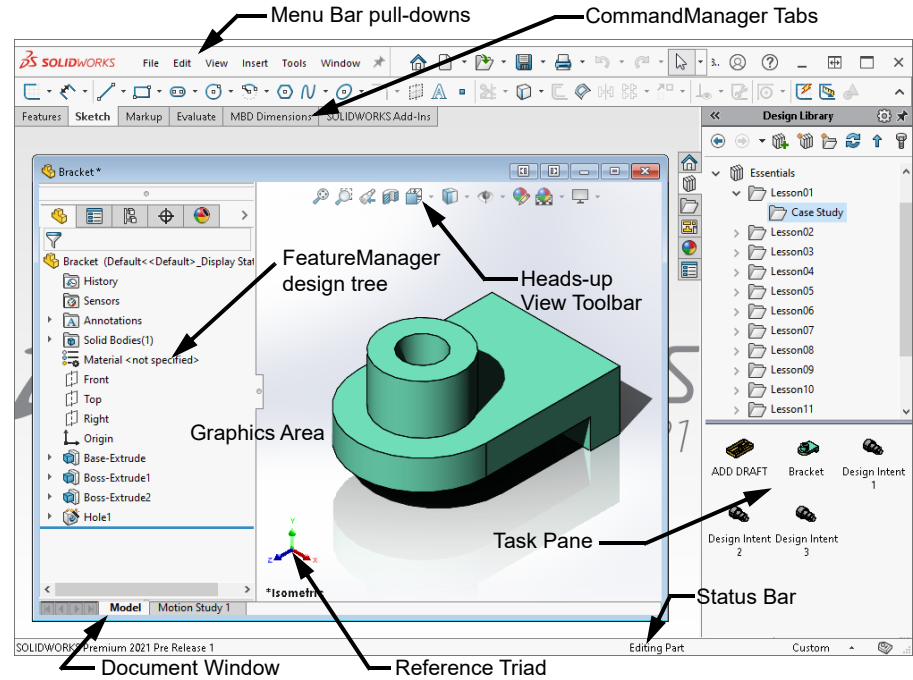

# Welcome Dialog Box

The **Welcome** dialog box opens with SOLIDWORKS to provide convenient ways to create new documents, open existing documents, and access SOLIDWORKS resources and news.

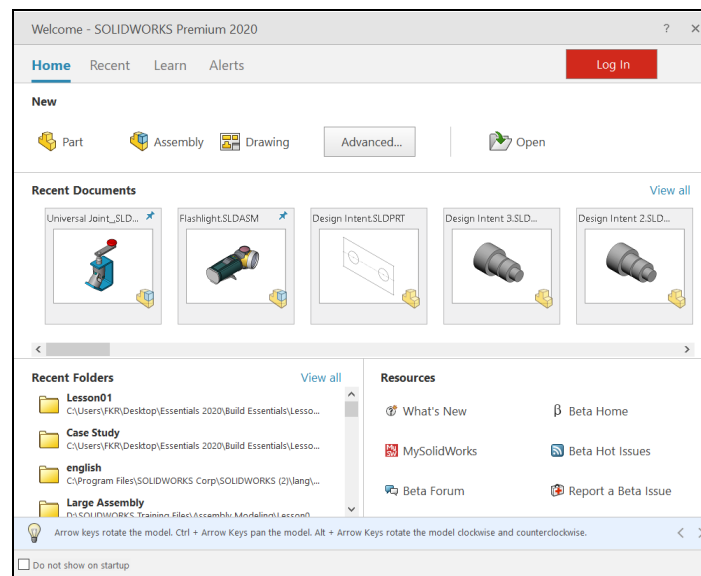

# Note

This dialog box can also be set to **Do not show on startup**.

## Pull-down Menus

The Pull-down menus provide access to many of the commands that the SOLIDWORKS software offers. Float over the right-facing arrow to access the menu. Click the pushpin to keep the menu open.

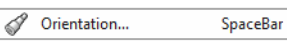

When a menu item has a right-pointing arrow like this: , it means that there is a sub-menu associated with that choice.

When a menu item is followed by ellipses like this: , it means that the option opens a dialog box with additional choices or information.

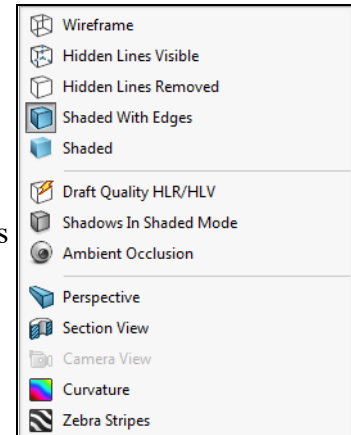

## Customizing Pull-down Menus

When the **Customize Menu** item is selected, each item appears with a check box. Clearing the check box removes the associated item from the menu.

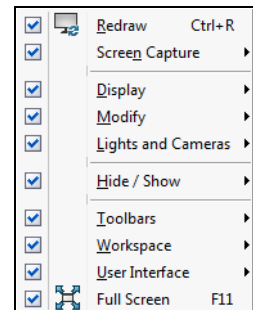

## Using the Command Manager

The **CommandManager** is a set of icons divided into tabs that are geared towards specific tasks. For example, the part version has several tabs to access commands related to features, sketches, and so on.

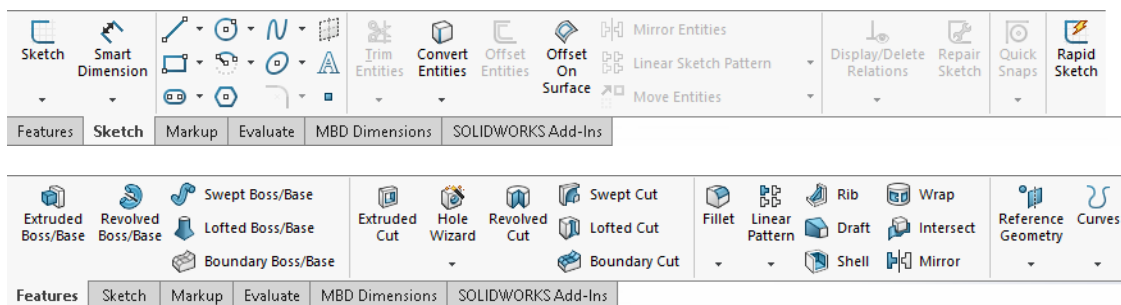

### Note

The CommandManager can be displayed with or without text on the buttons. These images show the **Use Large Buttons with Text** option.

### Adding and Removing CommandManager Tabs

The default settings display multiple CommandManager tabs for a part file. Others can be added or removed by right-clicking on any tab, clicking **Tabs**, and clicking or clearing the tab by name.

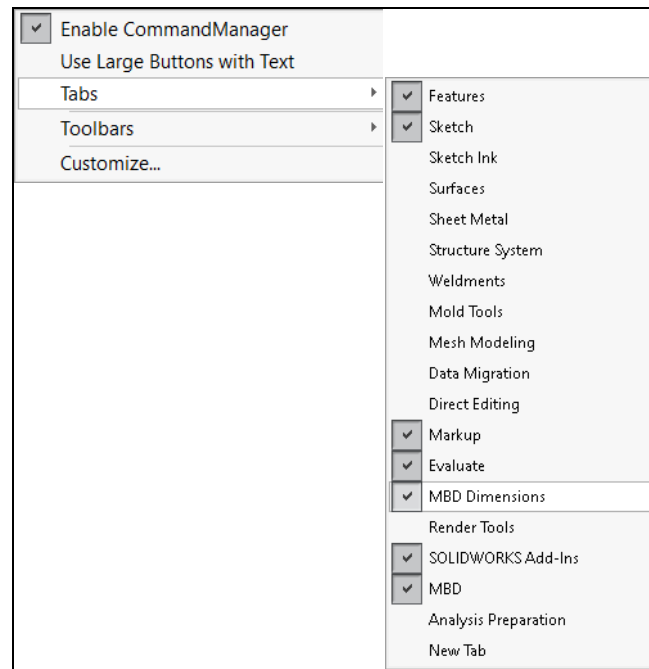

There are different sets of tabs for part, assembly and drawing files.

### FeatureManager Design Tree

The FeatureManager design tree is a unique part of the SOLIDWORKS software that visually displays all the features in a part or assembly. As features are created they are added to the FeatureManager design tree. As a result, the FeatureManager design tree represents the chronological sequence of modeling operations. The FeatureManager design tree also allows access to the editing of the features (objects) that it contains.

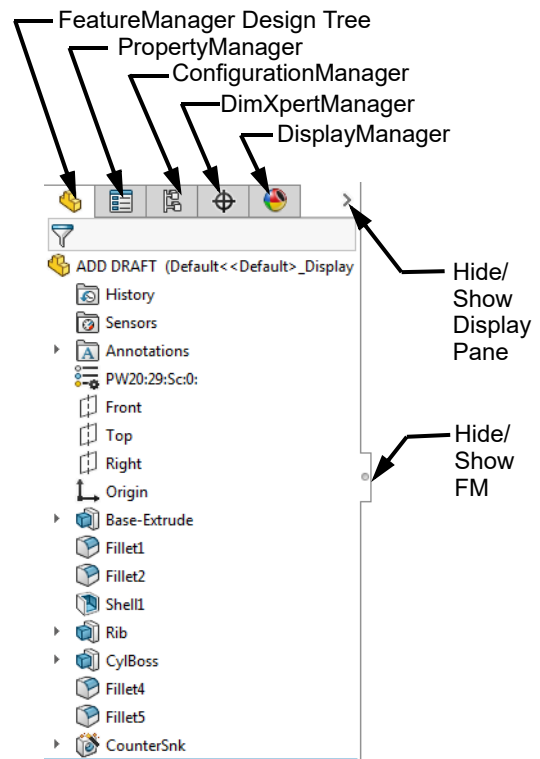

## Show and Hide FeatureManager Items

Many FeatureManager items (icons and folders) are hidden by default. In the image above, only the History, Sensors and Annotations folders are shown.

Click **Tools, Options, System Options, and FeatureManager** to control their visibility using one of the three settings explained below.

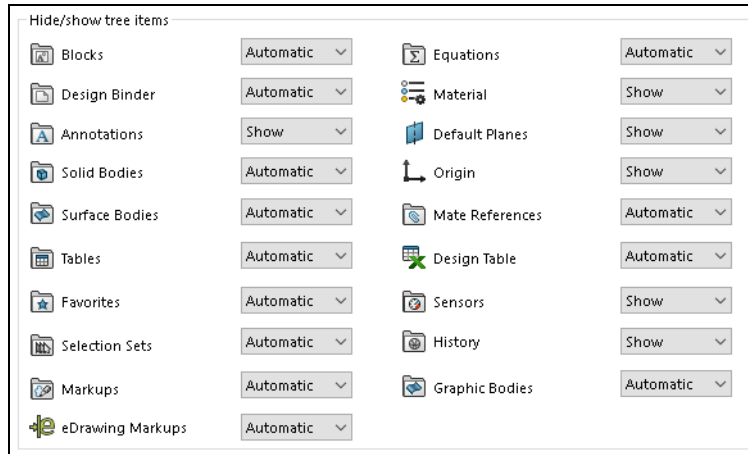

- **Automatic** - Hide the item when it is empty.
- **Hide** - Hide the item at all times.
- **Show** - Show the item at all times.

### Tip

The CommandManager or PropertyManager can be dragged and docked on the top, side or outside of the SOLIDWORKS window or to a different monitor.

### PropertyManager

Many SOLIDWORKS commands are executed through the PropertyManager. The PropertyManager occupies the same screen position as the FeatureManager design tree and replaces it when it is in use.

The top row buttons contain the standard **OK** and **Cancel** buttons.

Below the top row of buttons are one or more **Group Boxes** that contain related options. They can be opened (expanded) or closed (collapsed) and in many cases made active or inactive.

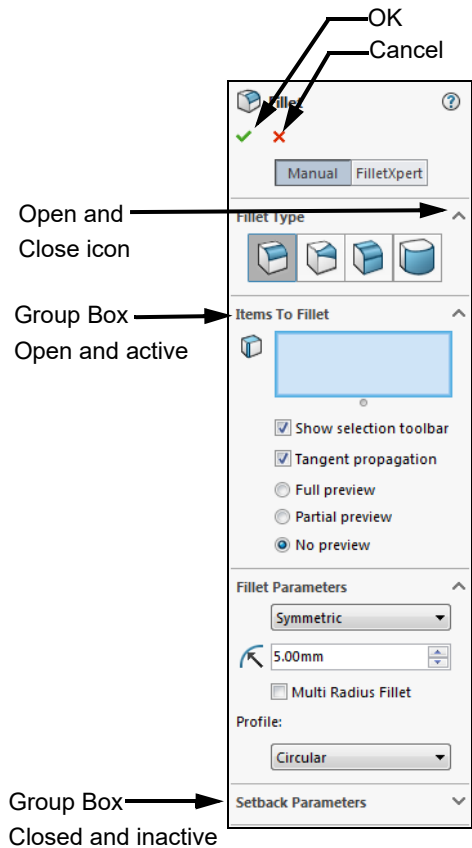

### Full Path Name

The full path name of the document can be seen as a tool tip when floating the cursor over the file name.

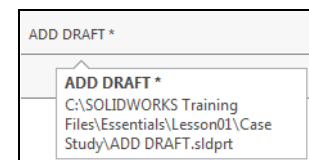

### Selection Breadcrumbs

**Selection Breadcrumbs** show the hierarchy of objects based on a selected piece of geometry. For example, selecting a face can lead to a series of objects including the feature, solid body, component, subassembly, and finally to the top level assembly.

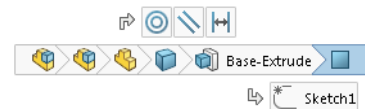







It also leads to the sketch of the feature and the mates attached to that component.

These visual objects can also be used for access. Right-clicking on the boss feature offers several editing tools including **Edit Feature** and **Hide**.

### Note

These objects and tools will be discussed in later lessons.

## Task Pane

The **Task Pane** window contains **SOLIDWORKS Resources** , **Design Library** , **File Explorer** , **View Palette** , **Appearances, Scenes, and Decals** , and **Custom Properties**  options. The window appears on the right by default but it can be moved and resized. It can be opened/closed, tacked or moved from its default position on the right side of the interface.

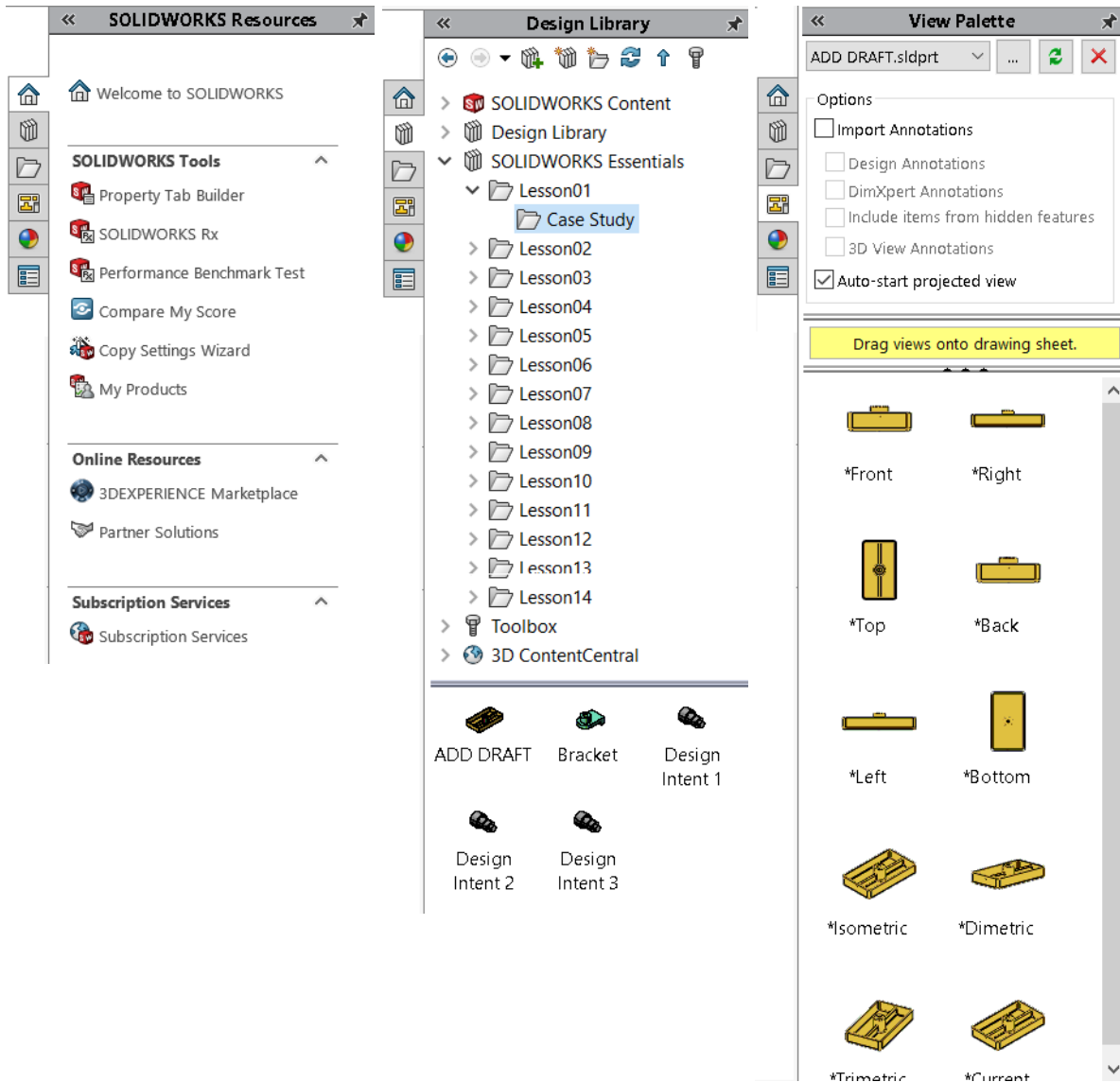

## Opening Labs with the File Explorer

You can open parts and assemblies required for lab exercises using the File Explorer.

- Open the **Task Pane**.
- Click **File Explorer** .
- Expand the **Essentials** folder used for the class files. It should be found under the **SOLIDWORKS Training Files** folder.
- Expand the lesson folder (Lesson01 for example) followed by either the **Case Study** or **Exercises** folder.
- Double-click a part or assembly file to open it.

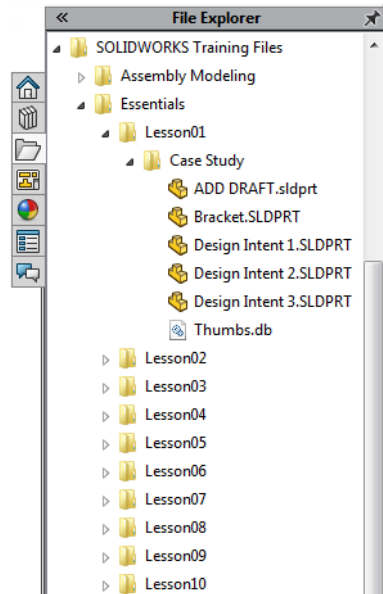

## Heads-up View Toolbar

The **Heads-up View** toolbar is a transparent toolbar that contains many common view manipulation commands. Many of the icons (such as the **Hide/Show Items** icon shown) are **Flyout Tool** buttons that contain other options. These flyouts contain a small down arrow  to access the other commands.

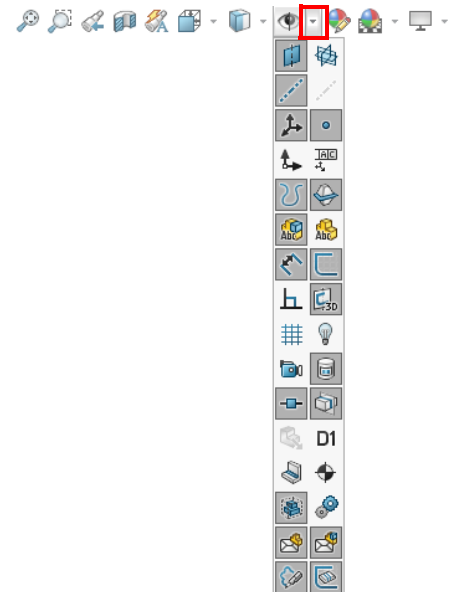

## Unselectable Icons

At times you will notice commands, icons, and menu options that are grayed out and unselectable. This is because you may not be working in the proper environment to access those options. For example, if you are working in a sketch (**Edit Sketch** mode), you have full access to all the sketch tools. However, you cannot select the icons such as fillet or chamfer on the Features tab of the CommandManager. This design helps the inexperienced user by limiting the choices to only those that are appropriate.

**To Preselect or Not?** As a rule, the SOLIDWORKS software does not require you to preselect objects before opening a menu or dialog box. For example, if you want to add some fillets to the edges of your model, you have complete freedom – you can select the edges first and then click the **Fillet** tool or you can click the **Fillet** tool and then select the edges. The choice is yours.

**Mouse Buttons** The left, right and middle mouse buttons have distinct meanings in SOLIDWORKS.

- **Left**  
Select objects such as geometry, menus buttons, and objects in the FeatureManager design tree.
- **Right**  
Activates a context sensitive shortcut menu. The contents of the menu differ depending on what object the cursor is over. These menus also represent shortcuts to frequently used commands.

**Shortcut Menu** At the top of the **Shortcut Menu** is the **Context Toolbar**. It contains some of the most commonly used commands in icon form.

Below it is the pull-down menu. It contains other commands that are available in the context of the selection, in this example a face.

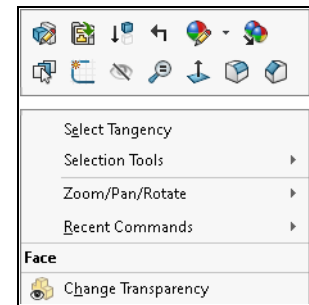

**Note** The Context toolbar will also become available as you make selections with the left mouse button. It provides quick access to common commands.

- **Middle**  
Dynamically rotates, pans or zooms a part or assembly. Pans a drawing.

## Keyboard Shortcuts

Some menu items indicate a keyboard shortcut like this:



SOLIDWORKS conforms to standard Windows conventions for such shortcuts as **Ctrl+O** for **File, Open**; **Ctrl+S** for **File, Save**; **Ctrl+Z** for **Edit, Undo** and so on. In addition, you can customize SOLIDWORKS by creating your own shortcuts.



**Multiple Monitor Displays**

SOLIDWORKS can take advantage of multiple monitor displays to span monitors and to move document windows or menus to a different monitor.

**Spanning Monitors**

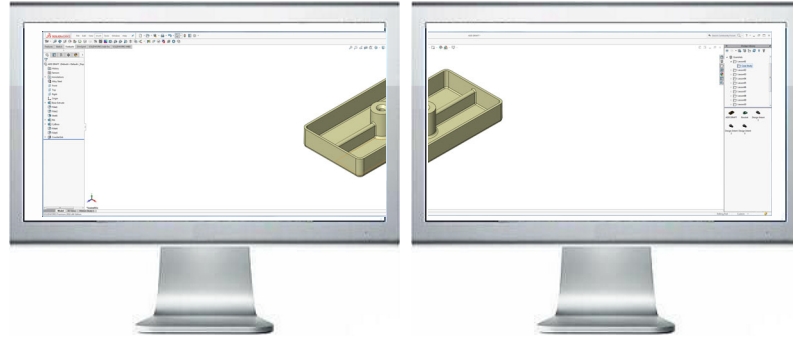
Click **Span Displays**  on the top bar of the SOLIDWORKS window to stretch the display across both monitors.

**Fitting to a Monitor**

Click either **Click to Tile Left**  or **Click to Tile Right**  on the top bar of a document to fit it to the left or right monitor.

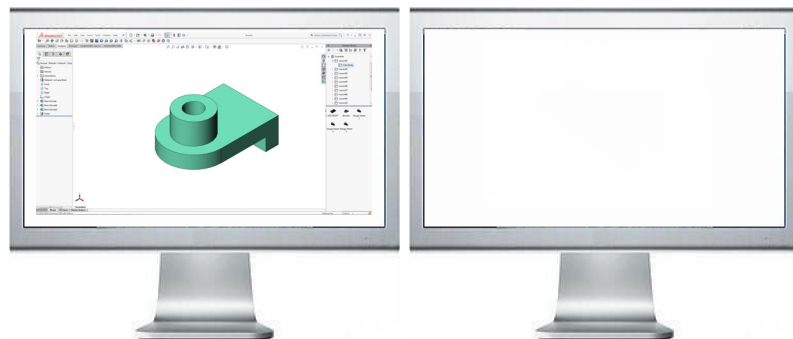
**System Feedback**

Feedback is provided by a symbol attached to the cursor arrow indicating what you are selecting or what the system is expecting you to select. As the cursor floats across the model, feedback will come in the form of symbols, riding next to the cursor. The illustration at the right shows some of the symbols: vertex, edge, face and dimension.

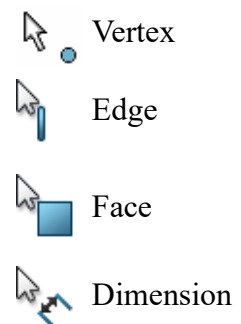

## Options

Located on the **Tools** menu, the **Options** dialog box enables you to customize the SOLIDWORKS software to reflect such things as your company's drafting standards as well as your individual preferences and work environment.

## Tip

Use the search bar in the upper right of the **Options** dialog box to find system options and document properties. Type the label of the check box, radio button, or other option to locate the page where the option resides.

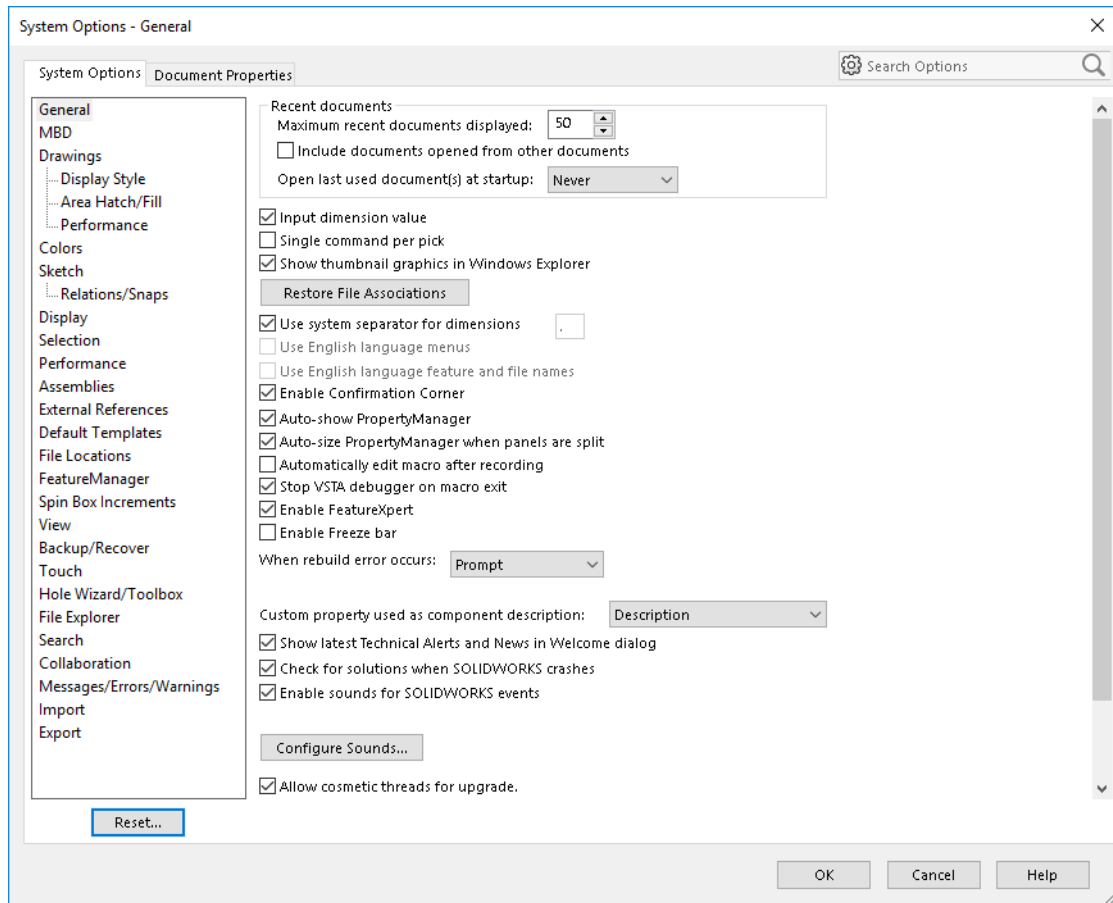

## Customization

You have several levels of customization. They are:

### ■ System options

The options grouped under the heading **System Options** are saved on your system and affect every document you open in your SOLIDWORKS session. System settings allow you to control and customize your work environment. For example, you might like working with colored viewport background. I don't. Since this is a system setting, parts or assemblies opened on your system would have a colored viewport. The same files opened on my system would not.

### ■ Document properties

These settings are applied to the individual document. For example, units, drafting standards, and material properties (density) are all document settings. They are saved with the document and do not change, regardless of whose system the document is opened on.

### ■ Document templates

Document templates are pre-defined documents that were set up with certain specific settings. For example, you might want two different templates for parts. One with English settings such as ANSI drafting standards and inch units, and one with metric settings such as millimeters units and ISO drafting standards. You can set up as many different document templates as you need. They can be organized into different folders for easy access when opening new documents. You can create document templates for parts, assemblies, and drawings.

### ■ Object

Many times the properties of an individual object can be changed or edited. For example, you can change the default display of a dimension to suppress one or both extension lines, or you can change the color of a feature.

## Search

The **Search** option can be used to find information from **SOLIDWORKS Help, Commands, Files and Models** on your system by searching for any part of the name (requires Windows Desktop Search engine), or **MySolidWorks** information. Search using this procedure:

- Choose which type of search you would like to do.
- Type a name or partial name into the **Search** box and click the search icon .

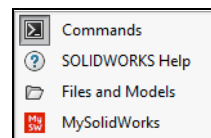



# Lesson 2

## Introduction to Sketching

Upon successful completion of this lesson, you will be able to:

- Create a new part.
- Insert a new sketch.
- Add sketch geometry.
- Establish sketch relations between pieces of geometry.
- Understand the state of the sketch.
- Extrude the sketch into a solid.

## 2D Sketching

This lesson introduces 2D sketching, the basis of modeling in SOLIDWORKS.

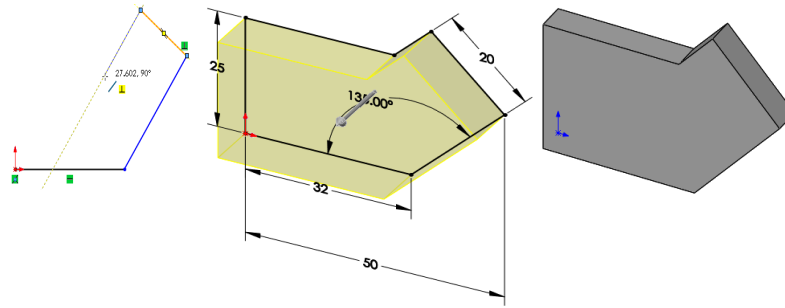

Sketches are used for all sketched features in SOLIDWORKS including:

- Extrusions
- Sweeps
- Revolves
- Lofts

The illustration below shows how a given sketch can form the basis of several different types of features.

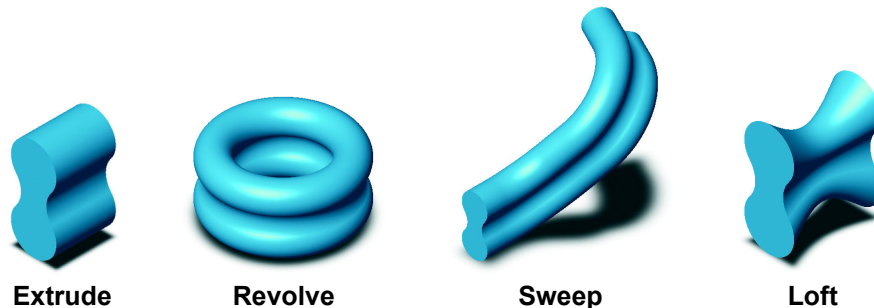

In this lesson, only extruded features will be covered. The others will be covered in detail in later lessons or courses.

## Stages in the Process

Every sketch has several characteristics that contribute to its shape, size and orientation.

- **New part**  
New parts can be created in inch, millimeter or other units. Parts are used to create and hold the solid model.
- **Sketches**  
Sketches are collections of 2D geometry that are used to create solid features.
- **Sketch geometry**  
Types of 2D geometry such as lines, circles and rectangles that make up the sketch.
- **Sketch relations**  
Geometric relationships such as horizontal and vertical are applied to the sketch geometry. The relations restrict the movement of the entities.

- **State of the sketch**  
Each sketch has a status that determines whether it is ready to be used or not. The state can be fully-, under- or over defined.
- **Sketch tools**  
Tools can be used to modify the sketch geometry that has been created. This often involves trimming or extending entities.
- **Extruding the sketch**  
Extruding uses the 2D sketch to create a 3D solid feature.

**Procedure**

The process in this lesson includes sketching and extrusions. To begin with, a new part file is created.

**Introducing:  
New Part**

The **New** tool creates a new SOLIDWORKS document from a selection of part, assembly or drawing templates. There are several training templates in addition to the default ones.

**Where to Find It**

- Menu Bar: **New** 
- Menu: **File, New**
- Keyboard Shortcut: **Ctrl+N**

**1 New part.**

Click **New**  and click the Part\_MM template from the Training Templates tab on the **New SOLIDWORKS Document** dialog box, and click **OK**.

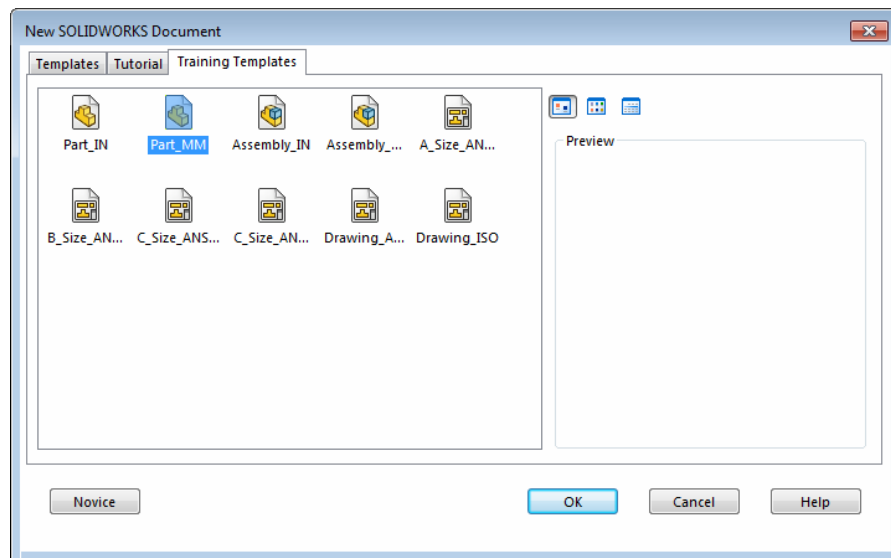

The part is created with the settings of the template including the units. This part template uses millimeters as the units. You can create and save any number of different templates, all with different settings.

## Saving Files

Saving files writes the file information in RAM to a location on a fixed disk. SOLIDWORKS provides three options for saving files. Each has a different effect on file references.

### Save

Copy the file in RAM to the fixed disk, leaving the copy in RAM open. If this file is being referenced by any open SOLIDWORKS files, there are no changes to the reference.

### Where to Find It

- Menu Bar: **Save** 
- Menu: **File, Save**
- Keyboard Shortcut: **Ctrl+S**

### Save As

Copy the file in RAM to the fixed disk under a new name or file type, replacing the file in RAM with the new file. The old file in RAM is closed *without* saving. If this file is being referenced by any *open* SOLIDWORKS files, you should update the references to this new file.

### Save As Copy to Disk

Copy the file in RAM to the fixed disk under a new name or file type, leaving the original in RAM open. If this file is being referenced by any open SOLIDWORKS files, you *should not* update the references to this new file.

### Save As Copy and Open

Copy the file in RAM to the fixed disk under a new name or file type, leaving both the copy and the original open.

## 2 Saving a part.

Click **Save**  and file the part under the name Plate. The extension, \*.sldprt, is added automatically. Click **Save**.

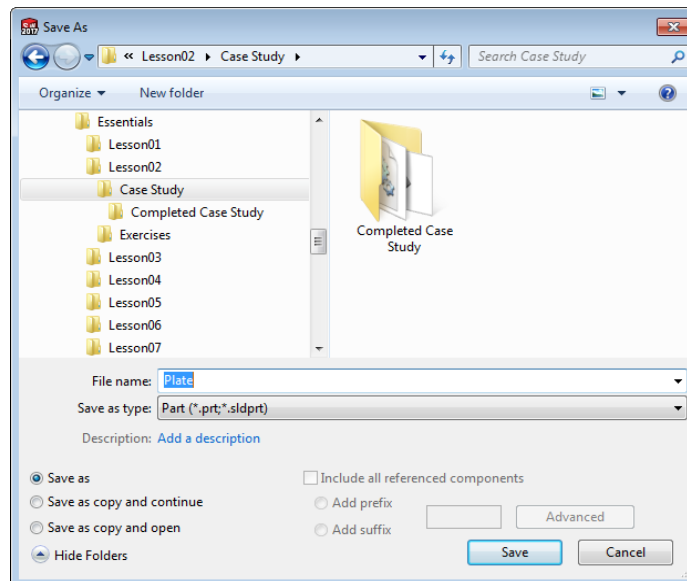

## What are We Going to Sketch?

The first feature of a part will be created in this section. That initial feature is just the first of many features needed to complete the part.

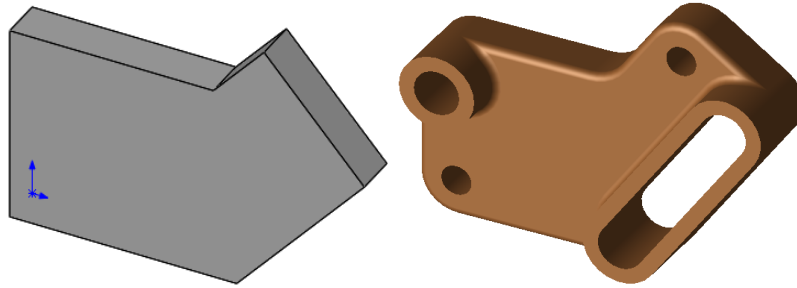

## Sketching

Sketching is the act of creating a 2D profile comprised of wireframe geometry. Typical geometry types are lines, arcs, circles and ellipses. Sketching is dynamic, with feedback from the cursor to make it easier.

## Default Planes



To create a sketch, you must choose a plane on which to sketch. The system provides three initial planes by default. They are Front Plane, Top Plane, and Right Plane.

## Introducing: Sketch

When creating a new sketch, the **Sketch** tool opens the sketcher on the currently selected plane or planar face. You also use the **Sketch** tool to edit an existing sketch.

If you have not preselected a face or plane before activating the **Sketch** tool, the cursor  appears indicating that you should select a face or plane.

## Where to Find It

- CommandManager: **Sketch > Sketch** 
- Menu: **Insert, Sketch**
- Shortcut Menu: Right-click a plane or planar face and click **Sketch** 

### 3 Open a new sketch.

Click . This will show all three default planes for selection in a Trimetric orientation. A Trimetric orientation is a pictorial view that is oriented so the three mutually perpendicular planes appear unequally foreshortened.

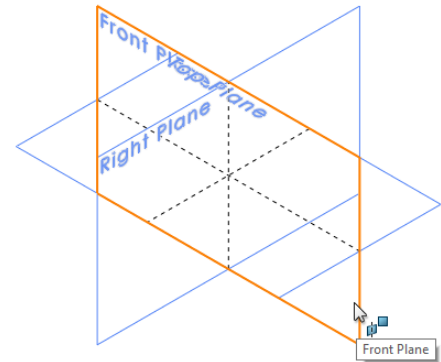

From the screen, choose the Front Plane. The plane will highlight and rotate.

#### Note

The **Reference Triad** (lower left corner) shows the orientation of the model coordinate axes (red-X, green-Y and blue-Z) at all times. It can help show how the view orientation has been changed relative to the Front Plane.



### 4 Sketch active.

The selected Front Plane rotates so it is parallel to the screen.

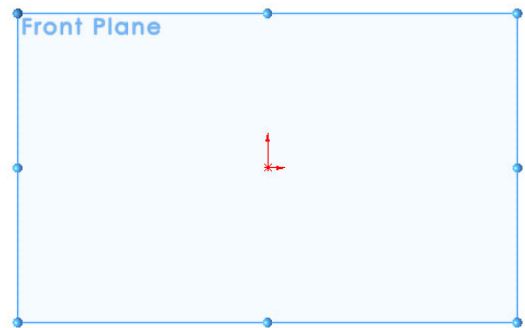

The  symbol represents the sketch origin. It is displayed in the color red, indicating that it is active.

#### Introducing: Confirmation Corner

When many SOLIDWORKS commands are active, a symbol or a set of symbols appears in the upper right corner of the graphics area. This area is called the **Confirmation Corner**.

#### Sketch Indicator

When a sketch is active, or open, the **Confirmation Corner** displays two symbols. One looks like a sketch. The other is a red X. These symbols provide a visual reminder that you are active in a sketch. Clicking the sketch symbol exits the sketch and *saves any changes*. Clicking the red X exits the sketch and discards any changes.



When other commands are active, the confirmation corner displays a check mark and an X. The check mark executes the current command. The X cancels the command.



Press the **D** key to move the confirmation corner to the pointer location.























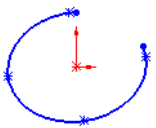

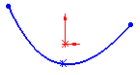

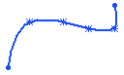

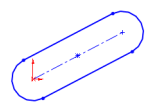

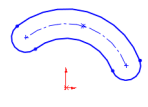





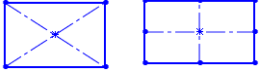

## Sketch Entities

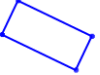
SOLIDWORKS offers a rich variety of sketch tools for creating profile geometry. In this lesson, only one of the most basic shapes will be used: **Lines**.

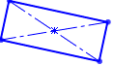
## Sketch Geometry

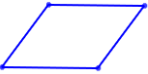
The following chart lists some of the sketch entities that are available:

Sketch Entity	Button	Geometry Example
Line		
Circle		
Perimeter Circle		
Centerpoint Arc		
Tangent Arc		
3 Point Arc		
Ellipse		
Partial Ellipse		
Parabola		
Spline		
Straight Slot		
Centerpoint Straight Slot		
3 Point Arc Slot		
Centerpoint Arc Slot		
Polygon		

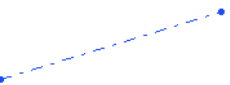
Sketch Entity	Button	Geometry Example
Corner Rectangle		
Center Rectangle (Construction geometry can be added to any type)		
3 Point Corner Rectangle		
3 Point Center Rectangle		
Parallelogram		
Point		
Centerline		

## Basic Sketching

The best way to begin sketching is by using the most fundamental shape, the **Line**.

### The Mechanics of Sketching

To sketch geometry, there are two techniques that can be used:

- **Click-Click**

Position the cursor where you want the line to start. Click (press and release) the left mouse button. Move the cursor to where you want the line to end. A preview of the sketch entity will follow the cursor like a rubber band. Click the left mouse button a second time. Additional clicks create a series of connected lines.



- **Click-Drag**

Position the cursor where you want the line to start. Press and hold the left mouse button. Drag the cursor to where you want the sketch entity to end. A preview of the sketch entity will follow the cursor like a rubber band. Release the left mouse button.

**Introducing:  
Insert Line**

The **Line** tool creates single line segments in a sketch. Horizontal and vertical lines can be created while sketching by watching for the feedback symbols on the cursor.



**Where to Find It**

- CommandManager: **Sketch > Line** 
- Menu: **Tools, Sketch Entities, Line**
- Shortcut Menu: Right-click in the graphics area and click **Sketch Entities, Line** 

**Introducing: Sketch  
Relations**

**Sketch Relations** are used to force a behavior on a sketch element thereby capturing design intent. They will be discussed in detail in *Sketch Relations* on page 41.

**5 Sketch a line.**

Click **Line**  and sketch a horizontal line from the origin. The  symbol appears at the cursor, indicating that a **Horizontal** relation will be automatically added to the line. The number indicates the length of the line. Click again to end the line.

**Important!**

Do not be too concerned with making the line the exact length. SOLIDWORKS software is dimension driven – the dimensions control the size of the geometry, not the other way around. Make the sketch approximately the right size and shape and then use dimensions to make it exact.

**6 Line at angle.**

Starting at the end of the first line, sketch a line at an angle.

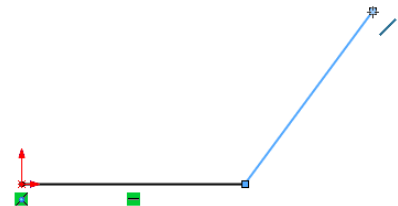
**Note**

The pencil icon at the cursor will be omitted for clarity.

## Inference Lines (Automatic Relations)

In addition to the relation symbols, dashed inference lines will also appear to help you “line up” with existing geometry. These lines include existing line vectors, normals, horizontals, verticals, tangents and centers.

Note that some lines capture actual geometric relations, while others simply act as a guide or reference when sketching. A difference in the color of the inference lines will distinguish them. In the picture at the right, the lines labeled “A” are yellow, and if the sketch line snaps to them, a tangent or perpendicular relationship will be captured.

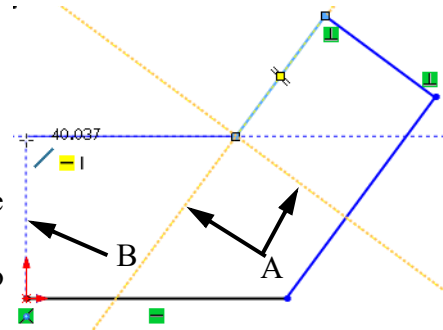

The line labeled “B” is blue. It only provides a reference, in this case vertical, to the other endpoint. If the sketch line is ended at this point, no vertical relation will be captured.

### Note

The display of Sketch Relations that appears automatically can be toggled on and off using **View, Hide/Show, Sketch Relations**. It will remain on during the initial phase of sketching.

### 7 Inference lines.

Create a line moving in a direction perpendicular to the previous line. This causes inference lines to be displayed while sketching. A **Perpendicular** relation is created between this line and the last one.

The cursor symbol indicates that you are capturing a perpendicular relation.

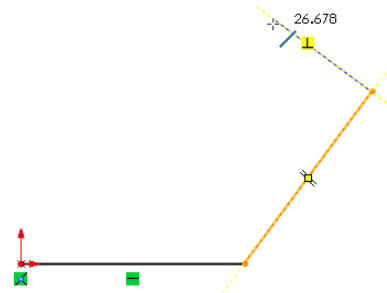

### 8 Perpendicular.

Create another perpendicular line from the last endpoint, again capturing a perpendicular relation.

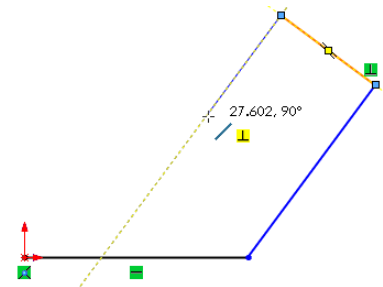

**9 Reference.**

Create a horizontal line from the last endpoint. Blue inferences are strictly for reference and do *not* create relations. They are displayed in blue. This reference is used to align the endpoint vertically with the origin.

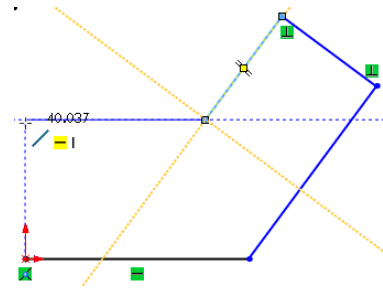

**10 Close.**

Close the sketch with a final line connected to the starting point of the first line.

A closed contour is confirmed with shading.

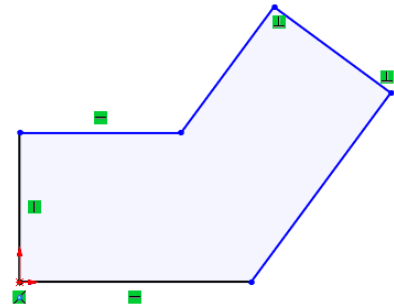

**Note**



Click **Shaded Sketch Contours**  from the **Sketch** CommandManager to toggle the shading on and off.

**Sketch Feedback**

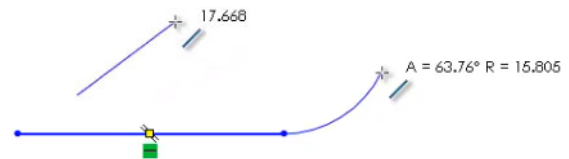
The sketcher has many feedback features. The cursor will change to show what type of entity is being created. It will also indicate what selections on the existing geometry, such as end, coincident (on) or midpoint, are available using an orange dot when the cursor is on it.

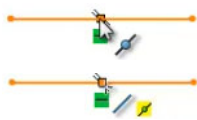

Three of the most common feedback symbols are:

Symbol	Icon	Description
Endpoint		Yellow concentric circles appear at the Endpoint when the cursor is over it.
Midpoint		The Midpoint appears as a yellow square. It changes to orange when the cursor hovers over the line.
Coincident (On Edge)		The quadrant points of the circle appear with a concentric circle over the centerpoint.

## Turning Off Tools

Turn off the active tool using *one* of these techniques:

- Menu Bar: **Select** 
- CommandManager: Click the active tool to toggle the tool off
- Keyboard Shortcut: **Esc**

### 11 Turn off the tool.

Press the **Esc** key on the keyboard to turn off the line tool.

## Status of a Sketch

Sketches can be in one of five definition states at any time. The status of a sketch depends on geometric relations between geometry and the dimensions that define it. The three most common states are:

### Under Defined

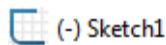

The sketch is inadequately defined, but the sketch can still be used to create features. This is good because many times in the early stages of the design process, there isn't sufficient information to fully define the sketch. When more information becomes available, the remaining definition can be added at a later time. Under defined sketch geometry is **blue** (by default).

### Fully Defined

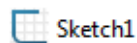

The sketch has all the information necessary to fully describe the geometry. Fully defined geometry is black (by default). As a general rule, when a part is released to manufacturing, the sketches within it should be fully defined.

### Over Defined

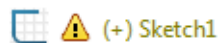

The sketch has duplicate dimensions or conflicting relations and it should not be used until repaired. Extraneous dimensions and relations should be deleted. Over defined geometry is **red** (by default).

### Note

The two other states are **No Solution Found** and **Invalid Solution Found**. They both indicate that there are errors that must be repaired.

## Rules That Govern Sketches

Different types of sketches will yield different results. Several different types are summarized in the table below. It is important to note that some of the techniques shown in the table below are advanced techniques that are covered either later in this course, or in other advanced courses.

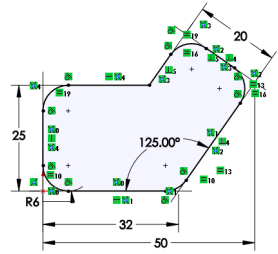
Sketch Type	Description	Special Considerations
	A typical "standard" sketch that is a neatly closed contour.	None required.

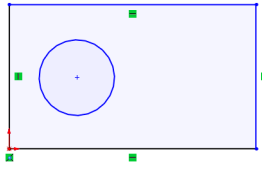
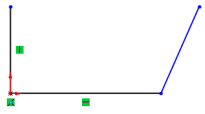
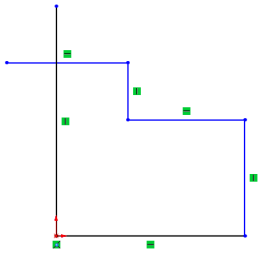
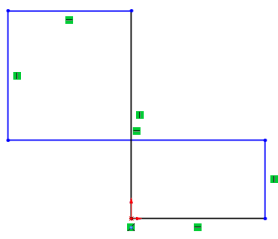
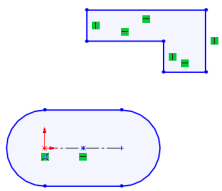
	<p>Multiple nested contours creates a boss with an internal cut.</p>	<p>None required.</p>
	<p>Open contour creates a thin feature with constant thickness.</p>	<p>None required.</p>
	<p>Corners are not neatly closed. <i>They should be.</i></p>	<p>Use the <b>Contour Select Tool</b>. Although this sketch will work, it represents poor technique and sloppy work habits. Do not do it.</p>
	<p>Sketch contains a self-intersecting contour.</p>	<p>Use the <b>Contour Select Tool</b>. If both contours are selected, this type of sketch will create a <b>Multibody Solid</b>. See <i>Multibody Solids</i> in the <i>Advanced Part Modeling</i> course. Although this will work, multibodies are an advanced modeling technique that you should not use until you have more experience.</p>
	<p>The sketch contains disjoint contours.</p>	<p>This type of sketch can create a <b>Multibody Solid</b>. See <i>Multibody Solids</i> in the <i>Advanced Part Modeling</i> course. Although this will work, multibodies are an advanced modeling technique that you should not use until you have more experience.</p>

**12 Current sketch status.**

The sketch is **Under Defined** because some of the geometry is blue. Note that endpoints of a line can be a different color and different state than the line itself. For example, the vertical line at the origin is black because it is (a) vertical, and (b) attached to the origin. However, the uppermost

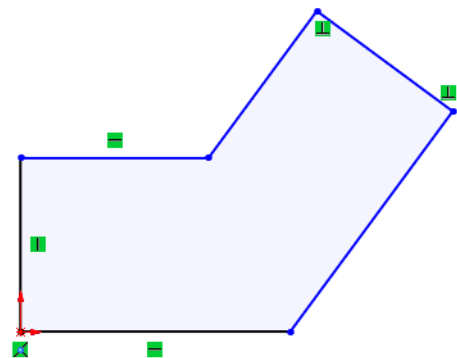

endpoint is blue because the length of the line is under defined.

### 13 Dragging.

Under defined geometry (**blue**) can be dragged to new locations. Fully defined geometry cannot. Drag the uppermost endpoint to change the shape of the sketch. The dragged endpoint appears as a blue dot.

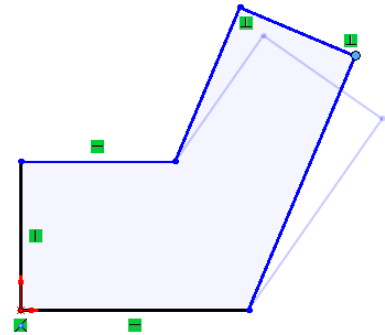

### 14 Undo the change.

Undo the last command by clicking the **Undo**  option. You can see (and select from) a list of the last few commands by clicking the down arrow menu. The keyboard shortcut for **Undo** is **Ctrl+Z**.

#### Tip

You can also **Redo**  a change, which reverts it back to the state prior to undo. The shortcut for redo is **Ctrl+Y**.

---

---

## Design Intent

The design intent, as discussed earlier, governs how the part is built and how it will change. In this example, the sketch shape must be allowed to change in these ways:

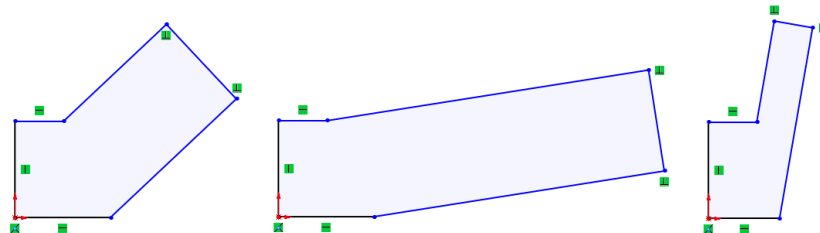

## What Controls Design Intent?

Design intent in a sketch is captured and controlled by a combination of two things:

### ■ Sketch relations

Create geometric relationships such as parallel, collinear, perpendicular, or coincident between sketch elements.

### ■ Dimensions

Dimensions are used to define the size and location of the sketch geometry. Linear, radial, diameter and angular dimensions can be added.

To fully define a sketch *and* capture the desired design intent requires understanding and applying a combination of relations and dimensions.

#### Tip

The relations are visible because **View, Hide/Show, Sketch Relations** is toggled on. If it is turned off, clicking the geometry will show the relations and open the PropertyManager.

The relations will be toggled *off* at this point, but they will still appear on selected geometry.

**Desired Design Intent**

In order for the sketch to change properly, the correct relations and dimensions are required. The required design intent is listed below:

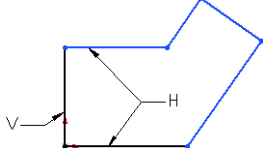
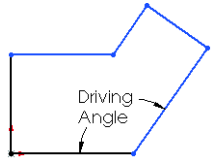
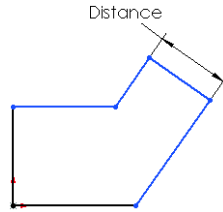
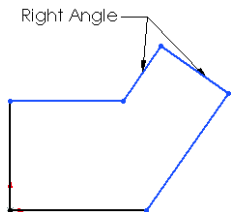
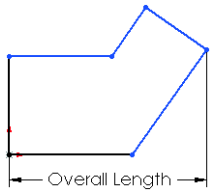
<p>Horizontal and vertical lines</p>	
<p>Angle value</p>	
<p>Parallel Distance value</p>	
<p>Right-angle corners, or perpendicular lines</p>	
<p>Overall length value</p>	

**Note**

The shading has been removed from table images for clarity.

**Sketch Relations**

**Sketch Relations** are used to force a behavior on a sketch element thereby capturing design intent. Some are automatic, others can be added as needed. In this example, we will look at the relations on one of the lines and examine how they affect the design intent of the sketch.

**Automatic Sketch Relations**

Automatic relations are added as geometry is sketched. We saw this as we sketched the outline in the previous steps. Sketch feedback tells you when automatic relations are being created.

## Added Sketch Relations

### Introducing: Display/Delete Relations

#### Where to Find It

For those relations that cannot be added automatically, tools exist to create relations based on selected geometry.

**Display/Delete Relations** shows the relations in a sketch. It also enables you to remove relations.

- CommandManager: **Sketch > Display/Delete Relations** 
- Menu: **Tools, Relations, Display/Delete**
- **Properties** PropertyManager: **Existing Relations**

#### 15 Display the relations associated with a line.

Click the uppermost angled line and the PropertyManager opens. The **Existing Relations** box in the PropertyManager lists the geometric relations that are associated with the selected line.

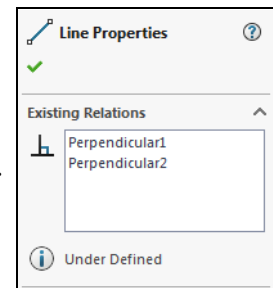
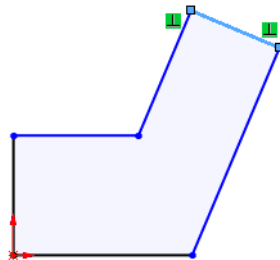

#### 16 Remove the relation.

Remove the uppermost relation by clicking the relation, either the symbol or in the PropertyManager, and pressing the **Delete** key. If the symbol is selected, it changes color and displays the entities it controls.

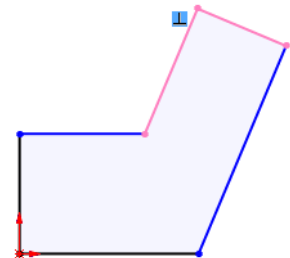

#### 17 Drag the endpoint.

Because the line is no longer constrained to be perpendicular, the sketch will behave differently when you drag it. Compare this to how the sketch behaved when you dragged it in step 13.

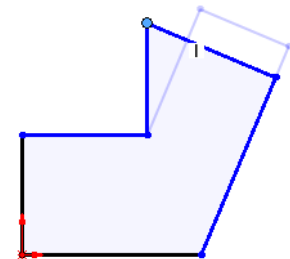

**Examples of Sketch Relations**

There are many types of **Sketch Relations**. Which ones are valid depends on the combination of geometry that you select. Selections can be the entity itself, endpoints or a combination. Depending on the selection, a limited set of options is made available. The following chart shows some examples of sketch relations. This is not a complete list of all geometric relations. Additional examples will be introduced throughout this course.

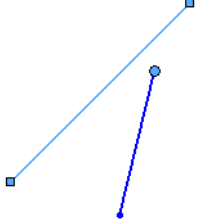
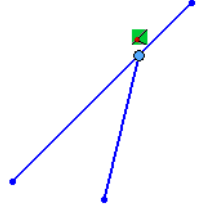
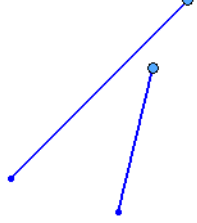
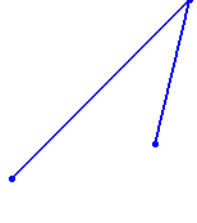
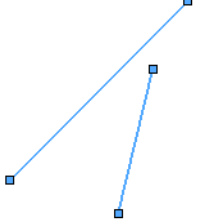
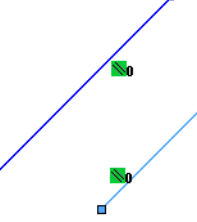
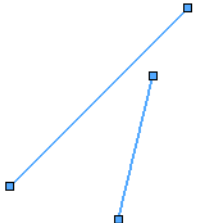
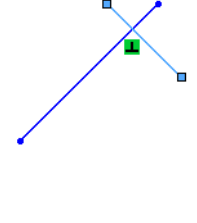
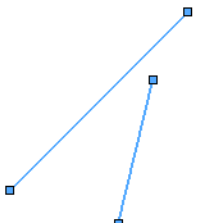
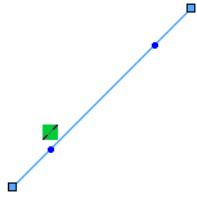
Relation	Before	After
<b>Coincident</b> between a line and an endpoint.		
<b>Merge</b> between two endpoints.		
<b>Parallel</b> between two or more lines.		
<b>Perpendicular</b> between two lines.		
<b>Collinear</b> between two or more lines.		

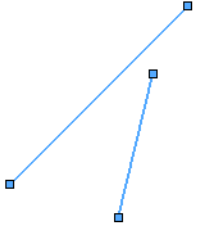
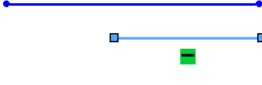
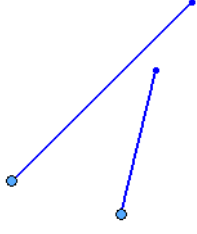
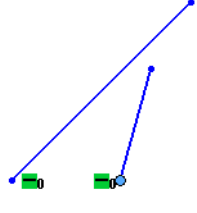
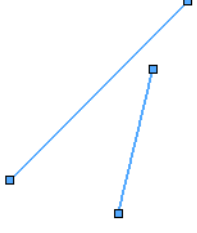
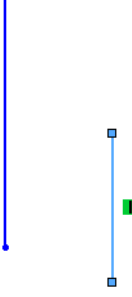
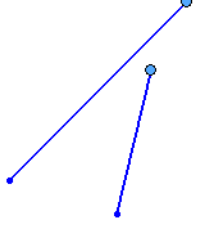
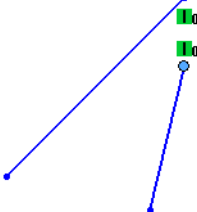
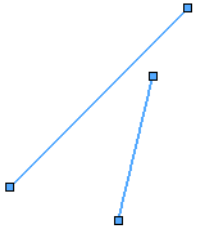
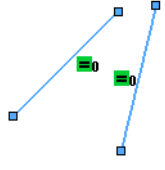

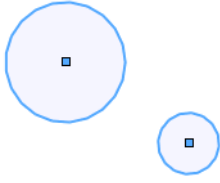
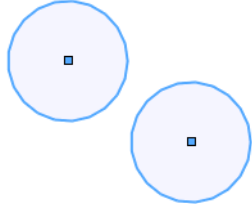
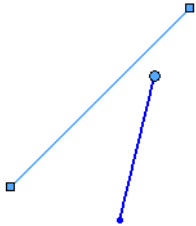
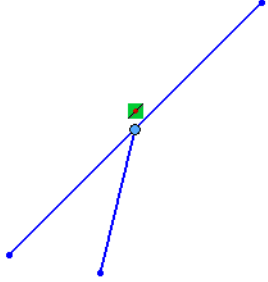
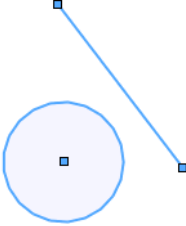
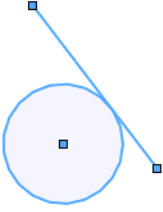
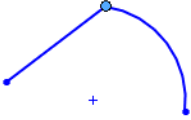
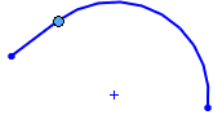
Relation	Before	After
<b>Horizontal</b> applied to one or more lines.		
<b>Horizontal</b> between two or more endpoints.		
<b>Vertical</b> applied to one or more lines.		
<b>Vertical</b> between two or more endpoints.		
<b>Equal</b> between two or more lines.		

Relation	Before	After
<b>Equal</b> between two or more arcs or circles.		
<b>Midpoint</b> between a line and an endpoint.		
<b>Tangent</b> between a line and an arc/circle or two arc/circles.		
<b>Tangent</b> between a line and an arc using the common endpoint.		

### Introducing: Add Relations

#### Where to Find It

**Add Relations** is used to create a geometric relationship such as parallel or collinear between sketch elements.

- CommandManager: **Sketch > Display/Delete Relations**  **>**  
**Add Relation** 
- Menu: **Tools, Relations, Add**
- Shortcut Menu: Select one or more sketch objects and click a relation

### Selecting Multiple Objects

As you learned in a previous lesson, you select objects with the left mouse button. What about when you need to select more than one object at a time? When selecting multiple objects, SOLIDWORKS follows standard Microsoft® Windows conventions: hold down the **Ctrl** key while selecting the objects.

**18 Add a relation.**

Hold down **Ctrl** and click the two lines. The context menu shows only those relations that are valid for the geometry selected. Click **Make Perpendicular**.

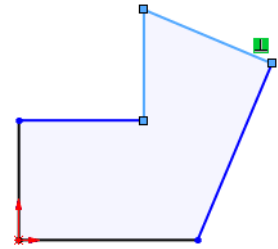
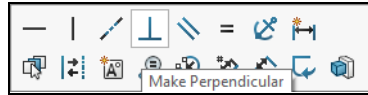

**19 Drag the sketch.**

Drag the sketch back into approximately its original shape.

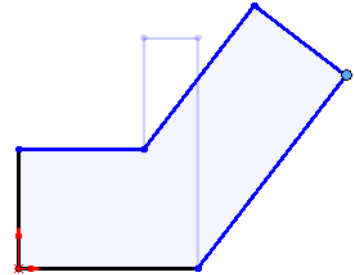

## Dimensions

Dimensions are another way to define geometry and capture design intent in the SOLIDWORKS system. The advantage of using a dimension is that it is used to both display the current value and change it.

### Introducing: Smart Dimensions

The **Smart Dimension** tool determines the proper type of dimension based on the geometry chosen, *previewing* the dimension before creating it. For example, if you pick an arc the system will create a radial dimension. If you pick a circle, you will get a diameter dimension, while selecting two parallel lines will create a linear dimension between them. In cases where the **Smart Dimension** tool isn't quite smart enough, you have the option of selecting endpoints and moving the dimension to different measurement positions.

### Where to Find It

- CommandManager: **Sketch > Smart Dimension** 
- Menu: **Tools, Dimensions, Smart**
- Shortcut Menu: Right-click in the graphics area and click **Smart Dimension** 

## Dimensioning: Selection and Preview

As you select sketch geometry with the dimension tool, the system creates a preview of the dimension. The preview enables you to see all the possible options by simply moving the mouse after making the selections. Clicking the left mouse button places the dimension in its current position and orientation. Clicking the right mouse button  locks only the orientation, allowing you to move the text before final placement by clicking the left mouse button.

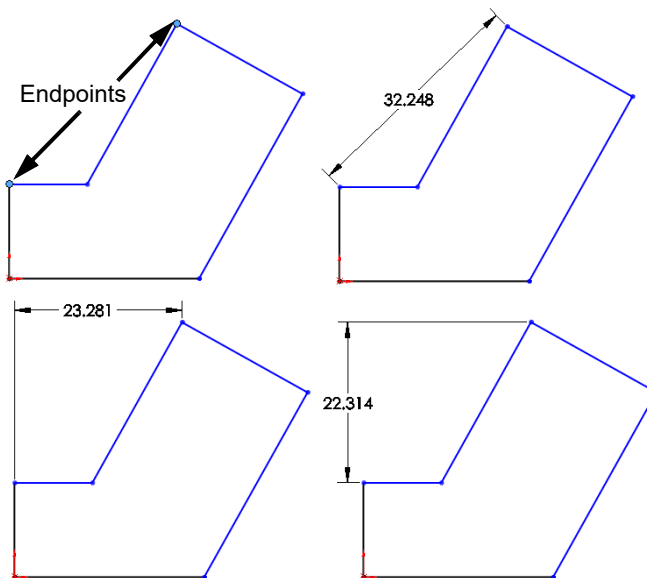

With the dimension tool and two endpoints selected, below are three possible orientations for a linear dimension. The value is derived from the initial point to point distance and may change based on the orientation selected.



### Note

Another option is to select the geometry that is to be dimensioned and click **Auto Insert Dimension** .

## 20 Adding a linear dimension.

Click **Smart Dimension**  and click the line shown and right-click  to lock in the orientation. Click again to place the text as shown. The dimension appears with a **Modify** tool displaying the current length of the line. The thumbwheel is used to incrementally increase/decrease the value using the middle mouse button. Or with the text highlighted, you can type a new value to change it directly.

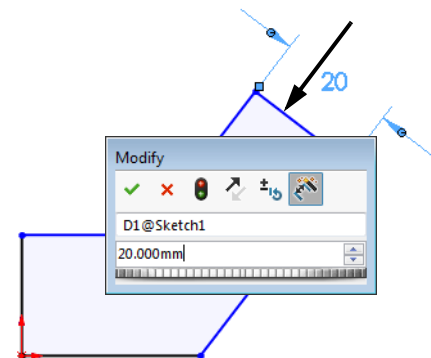

**Note**

A midpoint location can be inadvertently selected instead of the geometry itself. To avoid this, select the geometry slightly off center.

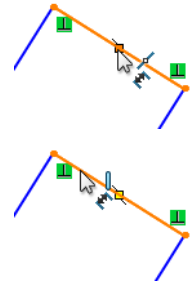

---

**The Modify Tool**

The modify tool that appears when you create or edit a dimension (parameter) has several options. The options available to you are:

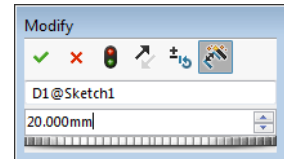

 Dial the value up or down.

- Save the current value and exit the dialog box.
- Restore the original value and exit the dialog box.
- Rebuild the model with the current value.
- Reverse the sense of the dimension.
- Change the thumbwheel increment value.
- Mark the dimension for drawing import.

**Note**

The dimension name can be changed in the upper section of the dialog box.

**Units in the Modify Tool**

Units different from the part units can be selected for the input. When typing the value, select the **Units >** menu and select input units.

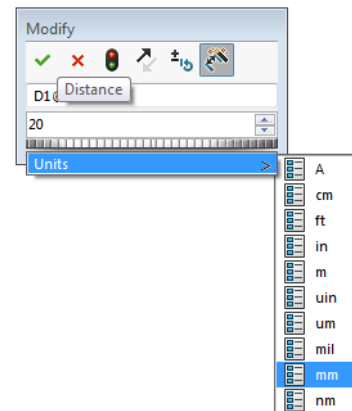

**Note**

Unit abbreviations and fractions can also be typed into the value field after the numeric value (for instance **0.375in** or **3/8"**).

**21 Set the value.**

Change the value to **20** and click the

**Save**  option. The dimension forces the length of the line to be 20mm.

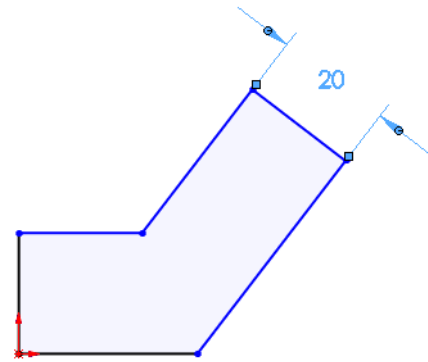
**Tip**

Pressing **Enter** has the same effect as clicking the **Save**  button.

**22 Linear dimensions.**

Add additional linear dimensions to the sketch as shown.

**Dimensioning Tip**

When you dimension a sketch, start with the smallest dimension first, and work your way to the largest.

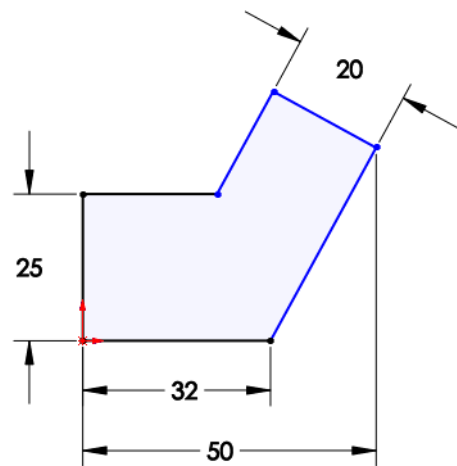

## Angular Dimensions

Angular dimensions can be created using the same dimension tool used to create linear, diameter and radial dimensions. Select either two lines that are both non-collinear and non-parallel, or select three non-collinear endpoints.

Depending on where you place the angular dimension, you can get the interior or exterior angle, the acute angle, or the obtuse angle. Possible placement options:

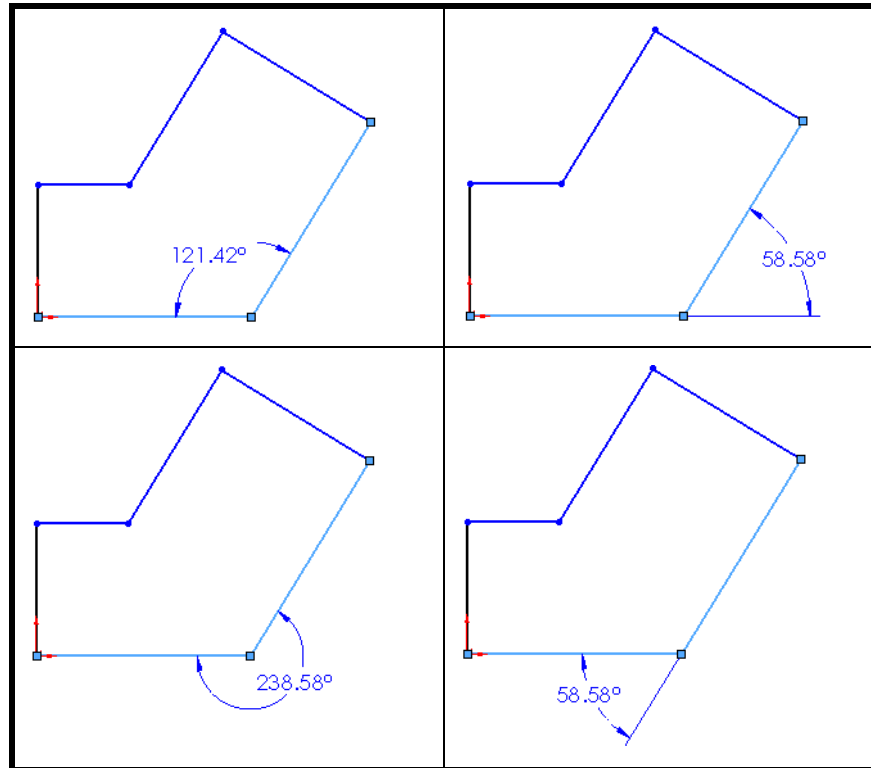

### 23 Angular dimension.

Using the dimension tool, create the angular dimension shown and set the value to **125°**.

The sketch is fully defined. See *Fully Defined* on page 38.

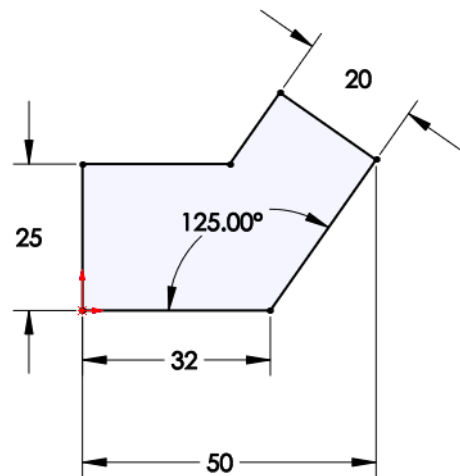

**Instant 2D**

**Instant 2D** can be used to manipulate sketch dimensions, dynamically changing the values using a graphic **Ruler**.

**Note**

The ruler is displayed to guide the drag. Moving closer to the ruler gradients allows you to snap to them.

**Where to Find It**

- CommandManager: **Sketch > Instant 2D** 

**24 Select dimension.**

The **Instant 2D** tool is on by default. Select the 125° dimension.

Click and hold the round ball handle at the tip of the arrow.

The value of the dimension, and the geometry, changes dynamically as the handle is dragged.

Drag the value to **135°** using the ruler.

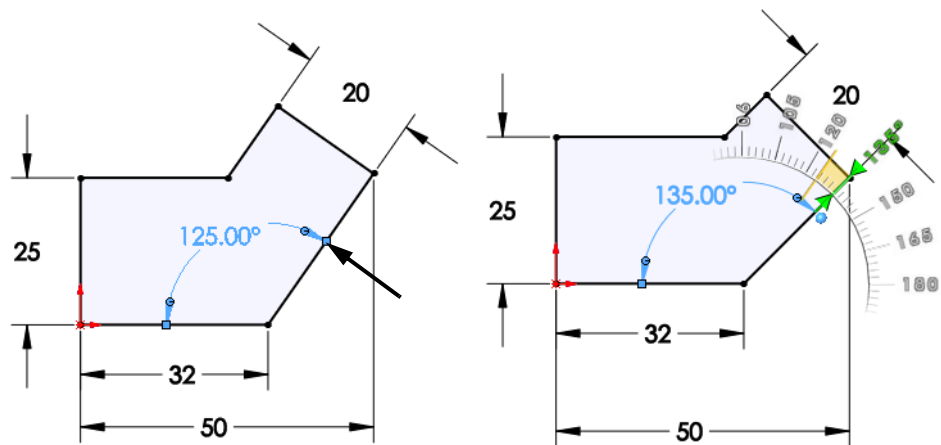
**Extrude**

Once the sketch is completed, it can be extruded to create the first feature. There are many options for extruding a sketch including the start and end conditions, draft and depth of extrusion, which will be discussed in more detail in later lessons. Typically, extrusions take place in a direction normal to the sketch plane, in this case the Front plane.

**Where to Find It**

- CommandManager: **Features > Extruded Boss/Base** 
- Menu: **Insert, Boss/Base, Extrude**

## 25 Extrude.

Click **Extruded Boss/Base** .

On the Features CommandManager tab, the options for other methods of creating features are listed along with **Extrude** and **Revolve**. They are unavailable because this sketch does not meet the conditions necessary for creating these types of features.

The view automatically changes to Trimetric and a preview of the feature is shown at the default depth.

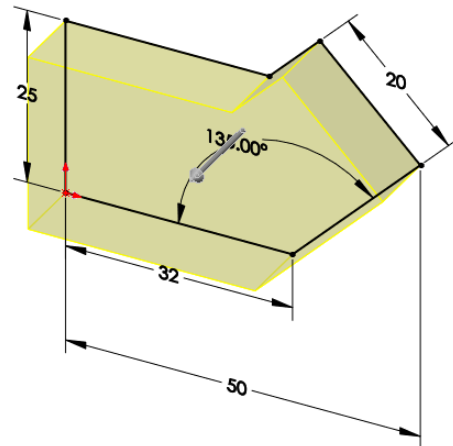

## Drag Handles and Rulers

Handles  appear that can be used to drag the preview to the desired depth. The handle is colored while dragging in the active direction. A callout shows the current depth value and a ruler.

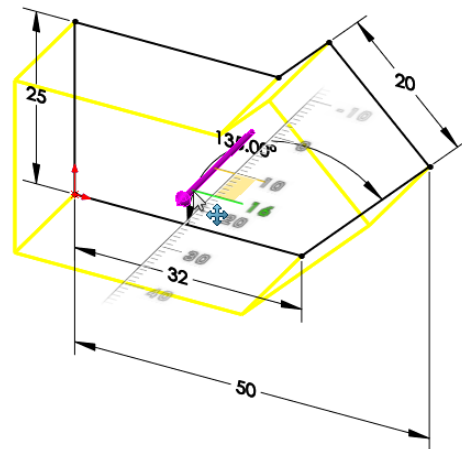

## 26 Extrude Feature settings.

Change the settings as shown.

- **End Condition = Blind**
-  **(Depth) = 6mm**

Click **OK**  to create the feature.

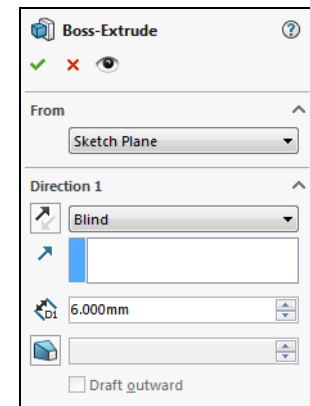

**Tip**

The **OK** button ✓ is just one way to accept and complete the process. A second is to press the **Enter** key.

A third method is the set of **OK/Cancel** buttons in the **Confirmation Corner** of the graphics area, or press the **D** key to bring it to the cursor.

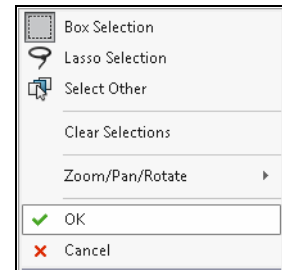

A fourth method is to right-click and click **OK** from the shortcut menu.

**27 Completed feature.**

The completed feature is the first solid, or feature of the part. The sketch is absorbed into the **Extrude1** feature.

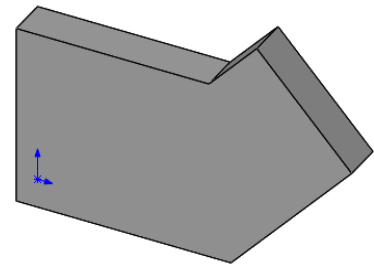
**Note**

Click the ▶ preceding the feature name to expand the feature and show the sketch.

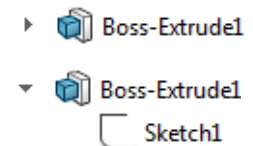
**28 Save and close.**

Click **Save**  then click **File, Close** to close the part.

## Sketching Guidelines†

Following is a collection of “rules of thumb” or best practices for sketching of which all SOLIDWORKS users should be aware. Some of these tips are covered in substantial detail in subsequent lessons within this book.

- Keep your sketches simple. Simple sketches are easier to edit, less likely to develop errors, and help with downstream features such as configurations.
- Make use of the origin in your first sketch.
- The first sketch of a new part should represent the main profile of the part.
- Create sketch geometry first, add geometric relationships second, and then add your dimensions last. Dimensions can sometimes interfere with the addition of required relations.
- Use geometric relations wherever possible to maintain design intent.
- Draw the sketch to approximately the right scale to prevent errors or geometry overlap when you start adding dimensions.
- Add or edit dimensions on the closest / smallest geometry first, then work your way to the outer / larger geometry to prevent geometry overlap.

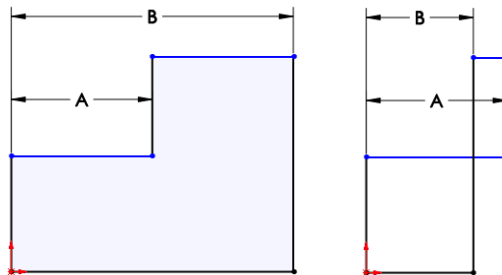

- Use relations, equations, and global variables to reduce the number of independent dimensions needed.
- Take advantage of symmetry. Use the **Mirror** or **Dynamic Mirror** sketch tool to mirror sketch elements and add symmetrical relations.
- Be flexible. It may be necessary to change the order in which you’re adding dimensions or relations. Drag the sketch geometry closer to the required location before adding dimensions.
- Fix errors as they occur. Use **SketchXpert** and **Check Sketch for Feature** which can quickly help you identify problems and correct them.

† Thanks to Joe Medeiros, Javelin Technologies.

**Exercise 1:  
Sketch and  
Extrude 1**

Create this part using the information and dimensions provided. Sketch and extrude profiles to create this part.

This lab reinforces the following skills:

- *Introducing: New Part* on page 29
- *Sketching* on page 31
- *Inference Lines (Automatic Relations)* on page 36
- *Dimensions* on page 46
- *Extrude* on page 51

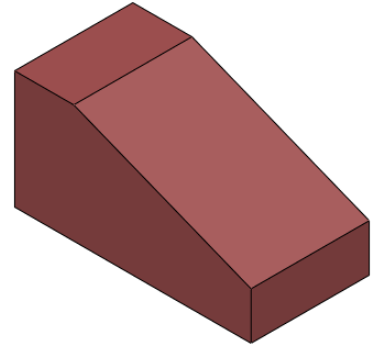

Units: **millimeters**

**1 New part.**

Create a new part using the Part\_MM template.

**2 Sketch.**

Create this sketch on the Front Plane using lines, automatic relations and dimensions.

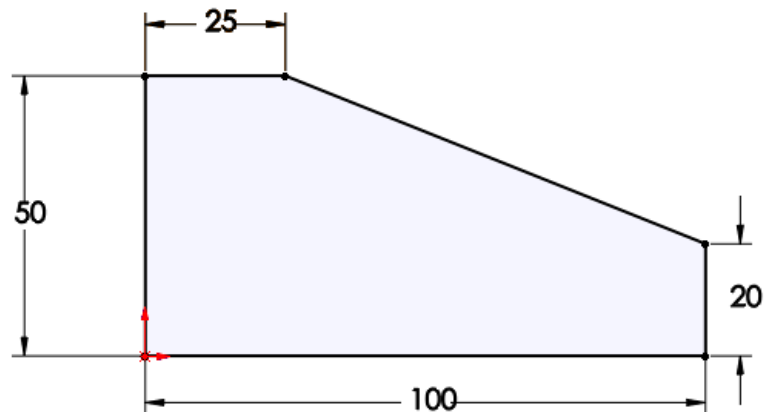
**3 Extrude.**

Extrude the sketch **50mm** in depth.

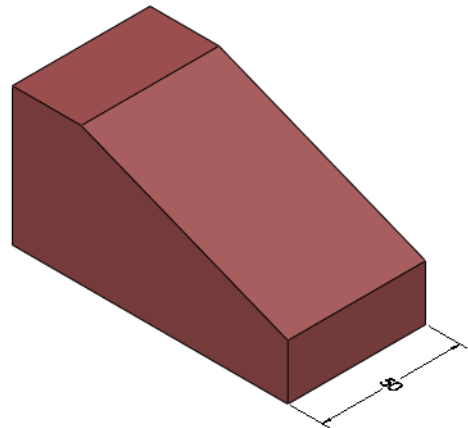
**4 Save and close the part.**

## Exercise 2: Sketch and Extrude 2

Create this part using the information and dimensions provided. Sketch and extrude profiles to create this part.

This lab reinforces the following skills:

- *Introducing: New Part* on page 29
- *Sketching* on page 31
- *Inference Lines (Automatic Relations)* on page 36
- *Dimensions* on page 46
- *Extrude* on page 51

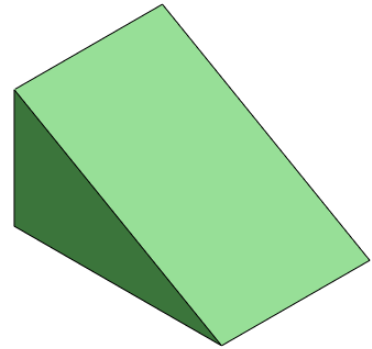

Units: **millimeters**

### 1 New part.

Create a new part using the Part\_MM template.

### 2 Sketch.

Create this sketch on the Front Plane using lines, automatic relations and dimensions.

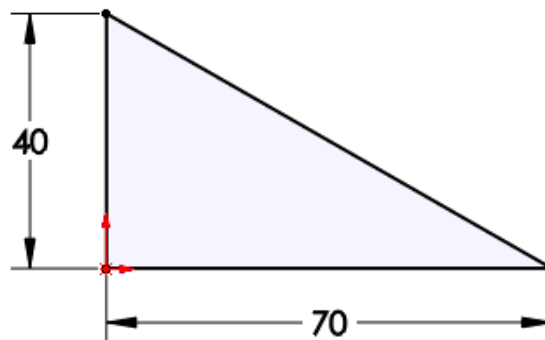

### 3 Extrude.

Extrude the sketch **50mm** in depth.

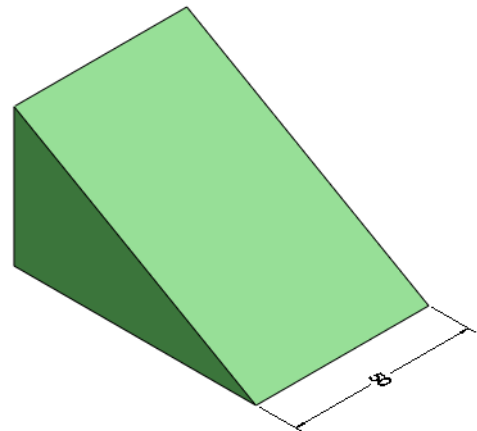

### 4 Save and close the part.

**Exercise 3:  
Sketch and  
Extrude 3**

Create this part using the information and dimensions provided. Sketch and extrude profiles to create this part.

This lab reinforces the following skills:

- *Introducing: New Part* on page 29
- *Sketching* on page 31
- *Inference Lines (Automatic Relations)* on page 36
- *Dimensions* on page 46
- *Extrude* on page 51

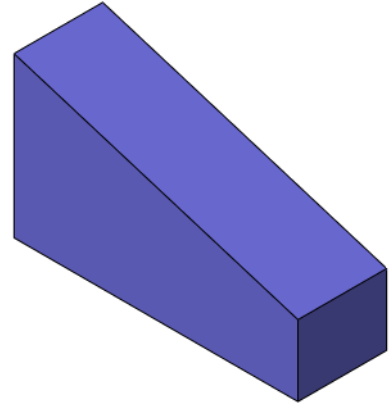

Units: **millimeters**

**1 New part.**

Create a new part using the Part\_MM template.

**2 Sketch.**

Create this sketch on the Front Plane using lines, automatic relations and dimensions.

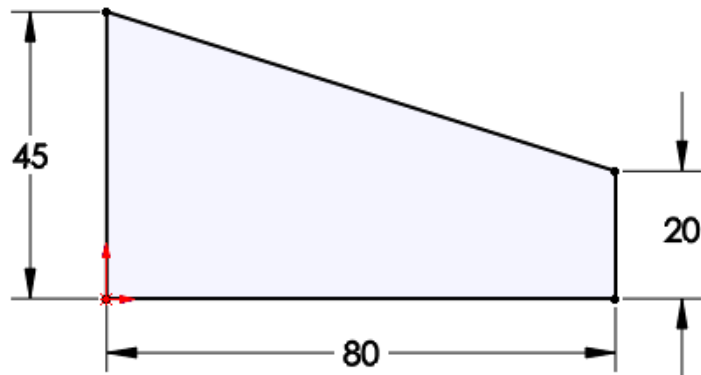
**3 Extrude.**

Extrude the sketch **25mm** in depth.

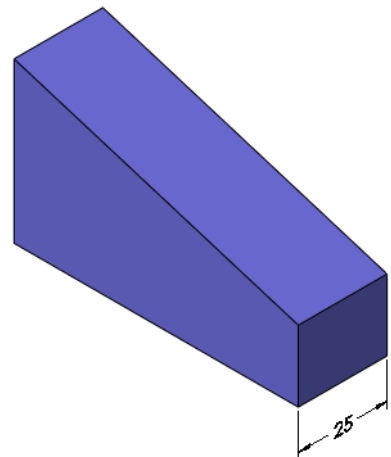
**4 Save and close the part.**

## Exercise 4: Sketch and Extrude 4

Create this part using the information and dimensions provided. Sketch and extrude profiles to create this part.

This lab reinforces the following skills:

- *Introducing: New Part* on page 29
- *Sketching* on page 31
- *Inference Lines (Automatic Relations)* on page 36
- *Dimensions* on page 46
- *Extrude* on page 51

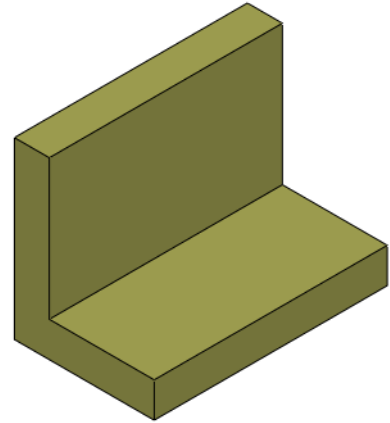

Units: **millimeters**

### 1 New part.

Create a new part using the Part\_MM template.

### 2 Sketch.

Create this sketch on the Front Plane using lines, automatic relations and dimensions.

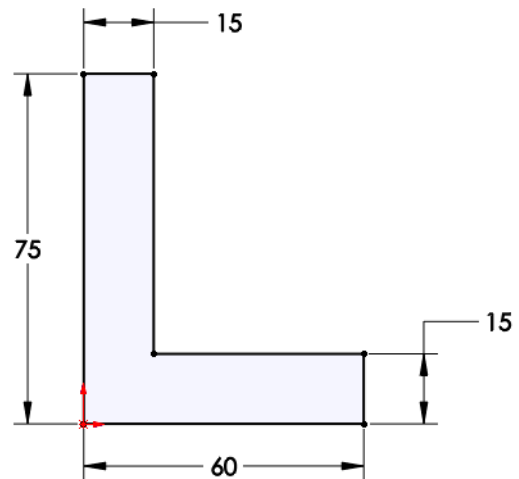

### 3 Extrude.

Extrude the sketch **100mm** in depth.

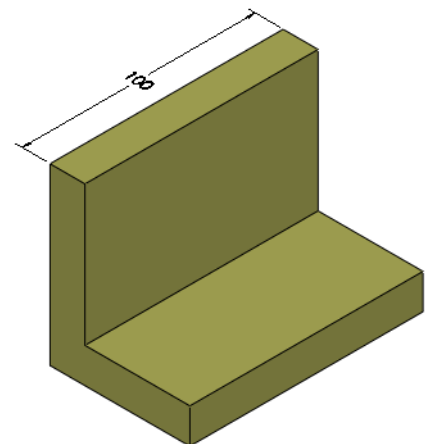

### 4 Save and close the part.

**Exercise 5:  
Sketch and  
Extrude 5**

Create this part using the information and dimensions provided. Sketch and extrude profiles to create the part.

This lab reinforces the following skills:

- *Introducing: New Part* on page 29
- *Sketching* on page 31
- *Inference Lines (Automatic Relations)* on page 36
- *Dimensions* on page 46
- *Extrude* on page 51

Units: **millimeters**

**1 New part.**

Create a new part using the Part\_MM template.

**2 Sketch.**

Create this sketch on the Front Plane using lines, automatic relations and dimensions.

Fully define the sketch.

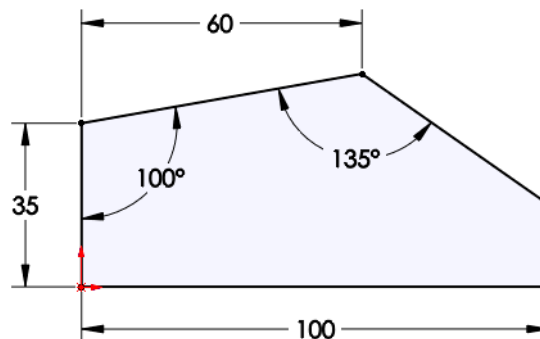
**3 Extrude.**

Extrude the sketch **25mm** in depth.

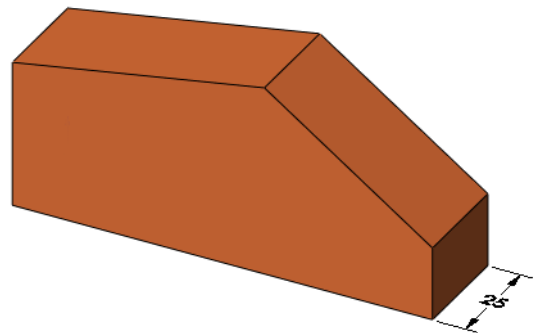
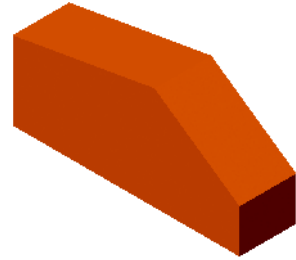
**4 Save and close the part.**

## Exercise 6: Sketch and Extrude 6

Create this part using the information and dimensions provided. Sketch and extrude profiles to create the part.

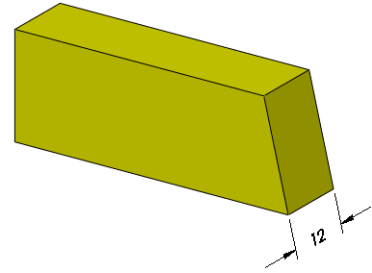

This lab reinforces the following skills:

- *Introducing: New Part* on page 29
- *Sketching* on page 31
- *Inference Lines (Automatic Relations)* on page 36
- *Dimensions* on page 46
- *Extrude* on page 51

Units: **millimeters**

### 1 New part.

Create a new part using the Part\_MM template.

### 2 Automatic relations.

Create this sketch on the Front Plane using lines and automatic relations. Show the **Perpendicular** and **Vertical** relations.

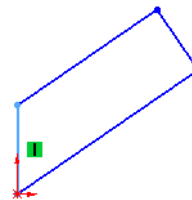
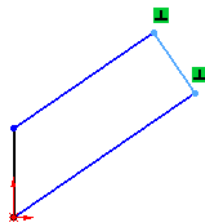

### 3 Dimensions.

Add dimensions to fully define the sketch.

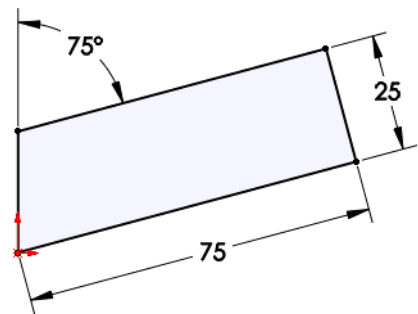

### 4 Extrude.

Extrude the sketch **12mm**.

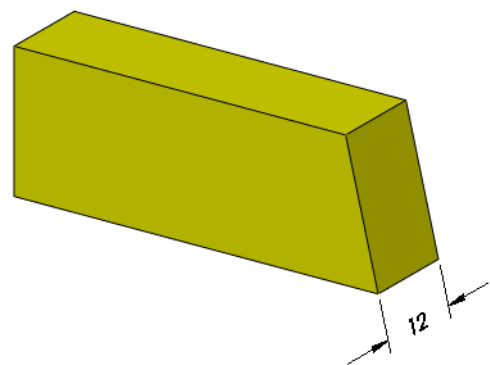

### 5 Save and close the part.

# Lesson 3

## Basic Part Modeling

Upon successful completion of this lesson, you will be able to:

- Choose the best profile for sketching.
- Choose the proper sketch plane.
- Extrude a sketch as a cut.
- Create Hole Wizard holes.
- Insert fillets on a solid.
- Use the editing tools Edit Sketch, Edit Feature and Rollback.
- Make a basic drawing of a part.
- Make a change to a dimension.
- Demonstrate the associativity between the model and its drawings.

## Basic Modeling

This lesson discusses the considerations that you make before creating a part, and shows the process of creating a simple one.

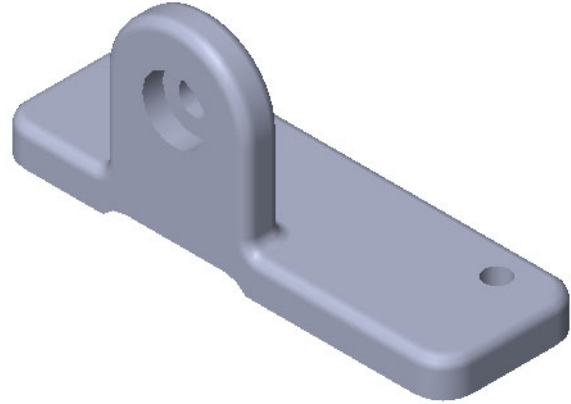

## Stages in the Process

The steps in planning and executing the creation of this part are listed below.

- **Terminology**  
What are the terms commonly used when talking about modeling and using the SOLIDWORKS software?
- **Profile choice**  
Which profile is the best one to choose when starting the modeling process?
- **Sketch plane choice**  
Once you've chosen the best profile, how does this affect your choice of sketch plane?
- **Design intent**  
What is design intent and how does it affect the modeling process?
- **New part**  
Opening the new part is the first step.
- **First feature**  
What is the first feature?
- **Bosses, cuts and hole features**  
How do you modify the first feature by adding bosses, cuts and holes?
- **Fillets**  
Rounding off the sharp corners – filleting.
- **Editing tools**  
Use three of the most common editing tools.
- **Drawings**  
Creating a drawing sheet and drawing views of the model.
- **Dimension changes**  
Making a change to a dimension changes the model's geometry. How does this happen?

**Terminology**

Moving to 3D requires some new terminology. The SOLIDWORKS software employs many terms that you will become familiar with through using the product. Many are terms that you will recognize from design and manufacturing such as cuts and bosses.

**Feature**

All cuts, bosses, planes and sketches that you create are considered Features. Sketched features are those based on sketches (boss and cut), and applied features are applied directly to existing geometry (fillet).

**Plane**

Planes are flat and infinite. They are represented on the screen with visible edges. They are used as the primary sketch surface for creating boss and cut features.

**Extrusion**

Although there are many ways to create features and shape the solid, for this lesson, only *extrusions* will be discussed. An extrusion will extend a profile along a path typically normal to the profile plane for some distance. The movement along that path becomes the solid model.

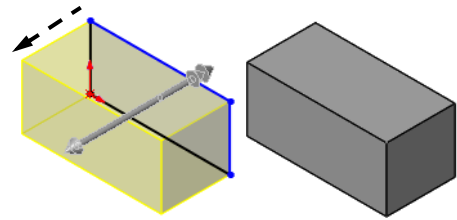
**Sketch**

In the SOLIDWORKS system, the name used to describe a 2D profile is *sketch*. Sketches are created on flat faces and planes within the model. They are generally used as the basis for bosses and cuts, although they can exist independently.

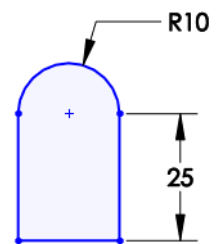
**Boss**

*Bosses* are used to *add* material to the model. The critical initial feature is always a boss. After the first feature, you may add as many bosses as needed to complete the design. As with the base, all bosses begin with a sketch.

**Cut**

A *Cut* is used to *remove* material from the model. This is the opposite of the boss. Like the boss, cuts begin as 2D sketches and remove material by extrusion, revolution, or other methods you will learn about.

**Fillets and Rounds**



*Fillets* and *rounds* are generally added to the solid, not the sketch. By nature of the faces adjacent to the selected edge, the system knows whether to create a round (removing material) or a fillet (adding material).

**Design Intent**

How the model should be created and changed, is considered the design intent. Relationships between features and the sequence of their creation all contribute to design intent.

## Choosing the Best Profile

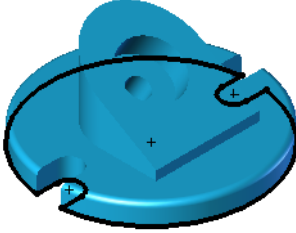
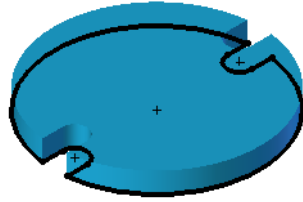
Choose the “best” profile for the model's base feature. This profile, when extruded, will generate more of the model than any other. Look at these models as examples.

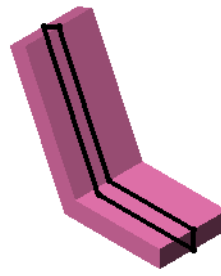
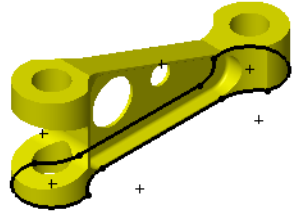
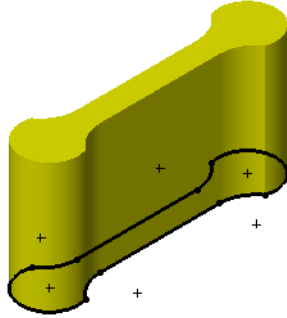
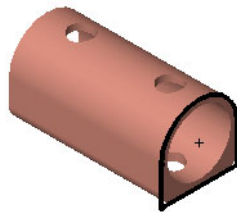
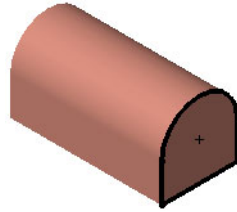
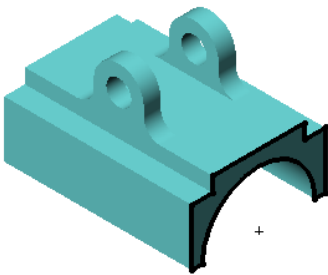
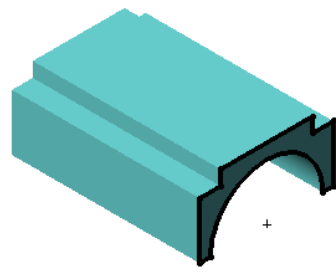
Part	Best Profile Extruded
	
	
	
	
	

## Choosing the Sketch Plane

Once the best profile is determined, the next step is to decide which view to use and select the plane with the same name for sketching it. The SOLIDWORKS software provides three planes; they are described below.

### Planes

There are three default planes, labeled **Front Plane**, **Top Plane** and **Right Plane**. Each plane is infinite, but has screen borders for viewing and selection. Also, each plane passes through the origin and is mutually perpendicular to the others.

The planes can be renamed. In this course the names **Front Plane**, **Top Plane** and **Right Plane** are used. This naming convention is used in other CAD systems and is comfortable to many users.

Although the planes are infinite, it may be easier to think of them as forming an open box, connecting at the origin. Using this analogy, the inner faces of the box are the potential sketch planes.

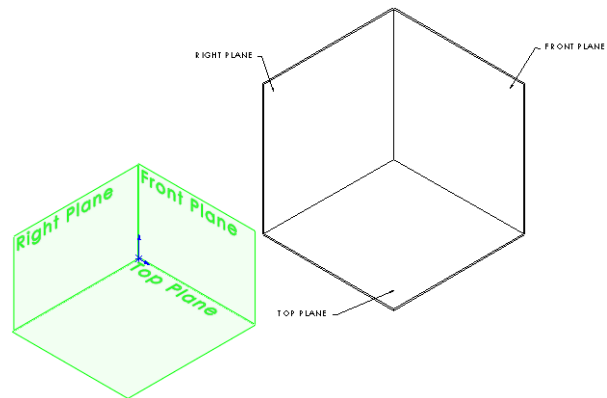

### Placement of the Model

The part will be placed into the box three times. Each time the best profile will contact or be parallel to one of the three planes. Although there are many combinations, the choices are limited to three for this exercise.

When choosing the sketch plane, consider the part's appearance and its orientation in an assembly. The appearance dictates how the part will be oriented in standard views such as the **Isometric**. It also determines how you will spend most of your time looking at the model as you create it.

The part's orientation in an assembly dictates how it is to be positioned with respect to other, mating parts.

### Orient the Model for the Drawing

Another consideration when deciding which sketch plane to use is how you want the model to appear on the drawing when you detail it. You should build the model so that the front of the model is the same as the **Front view** in the drawing. This saves time during the detailing process because you can use predefined views.

In the first example, the best profile is in contact with the Top plane.

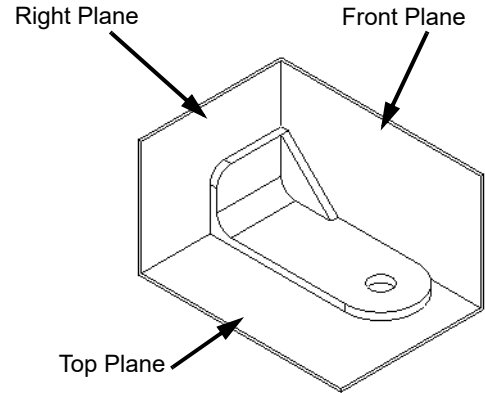

In the second example, it is contacting the Front plane.

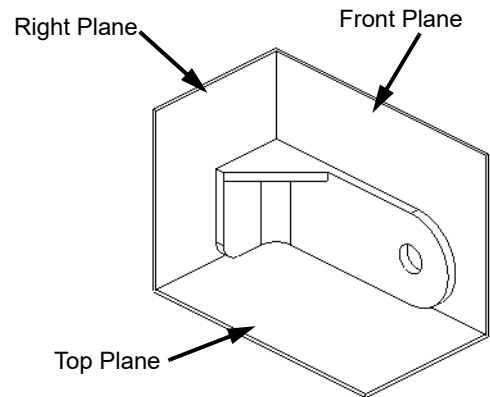

The last example shows the best profile in contact with the Right plane.

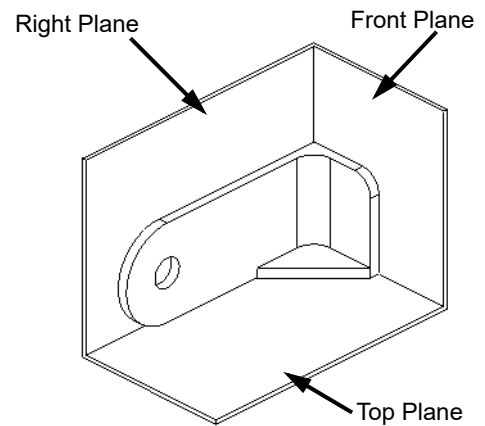

**Chosen Plane**

The Top plane orientation seems to be the best. This indicates that the best profile should be sketched on the Top plane of the model.

**How it Looks on the Drawing**

By giving careful thought to which plane is used to sketch the profile, the proper views are easily generated on the detail drawing.

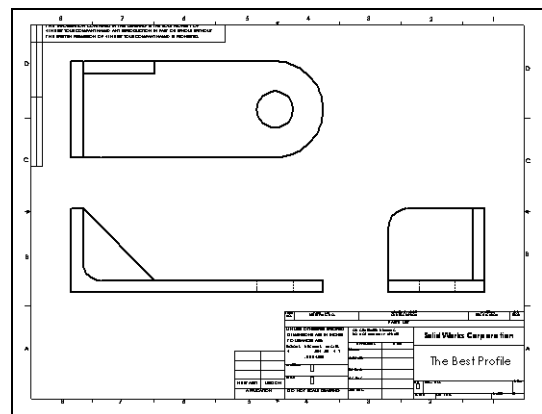

## Details of the Part

The part we will be creating is shown below. There are two main boss features, some cuts, and fillets.

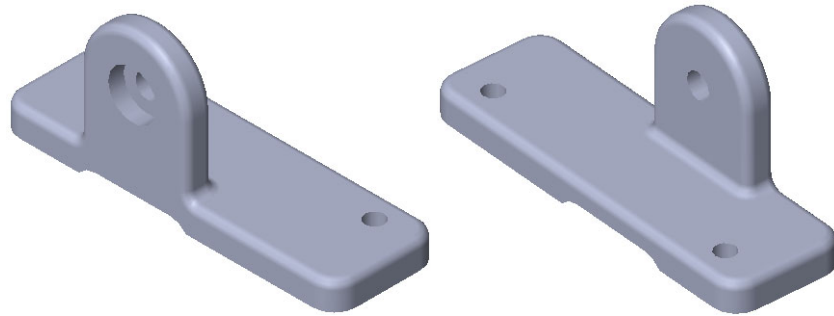

## Standard Views

The part is shown here in four standard views.

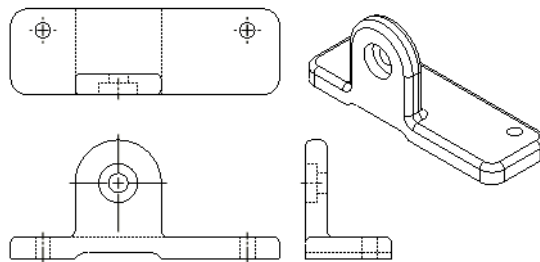

## Main Bosses

The two main bosses have distinct profiles in different planes. They are connected as shown in the exploded view at right.

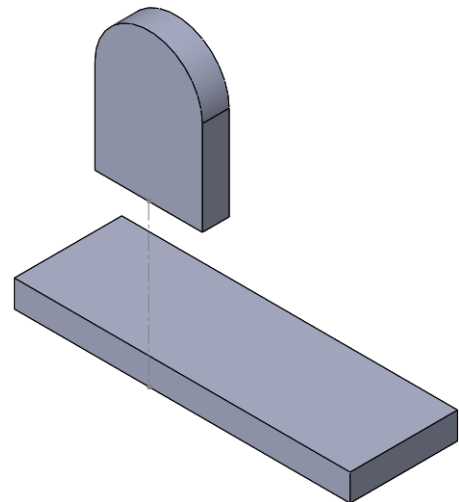

## Best Profile

The first feature of the model is created from the rectangular sketch shown overlaid on the model. This is the best profile to begin the model.

The rectangle will then be extruded as a boss to create the solid feature.

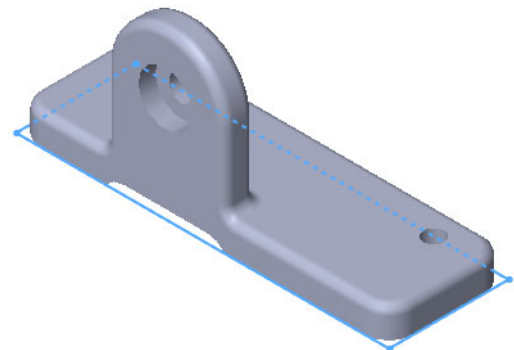

## Sketch Plane

Placing the model “in the box” determines which plane should be used to sketch on. In this case it will be the Top plane.

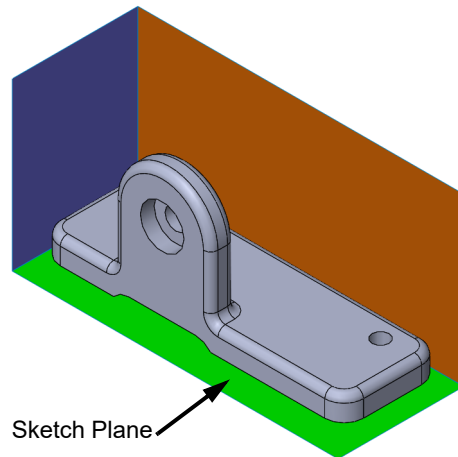

## Design Intent

The design intent of this part describes how the part’s relationships should or should not be created. As changes to the model are made, the model will behave as intended.

- All holes are through holes.
- The slot is aligned with the tab.
- The counterbored hole in the front shares the same center point as the rounded face of the tab.

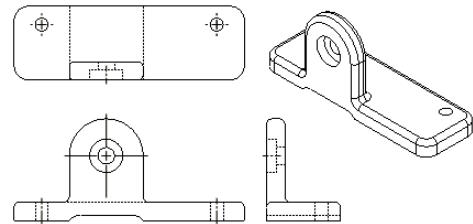

---

## Procedure

The modeling process includes sketching and creating bosses, cuts and fillets. To begin with, a new part file is created.

### 1 New part.

Click **New** , or click **File, New**. Create a new part using the Part\_MM template and **Save** it as Basic.

### 2 Select the sketch plane.

Insert a new sketch and choose the Top Plane.

## Tip

A plane doesn’t have to be shown in order to be used; it can be selected from the FeatureManager design tree.

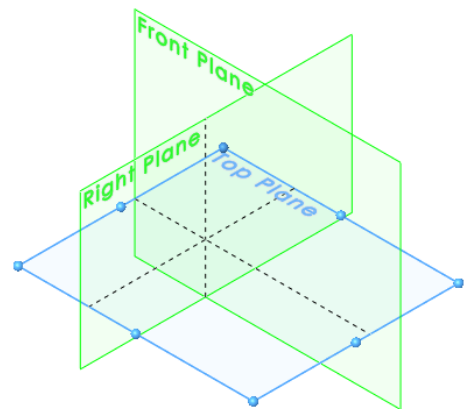







**Sketching the First Feature**

Create the first feature by extruding a sketch into a boss. The first feature is always a boss, and it is the first solid feature created in any part. Begin with the sketch geometry, a rectangle.

**Introducing: Corner Rectangle**

**Corner Rectangle** is used to create a rectangle in a sketch. The rectangle is comprised of four lines (two horizontal and two vertical) connected at the corners. It is sketched by indicating the locations of two diagonal corners. There are several other rectangle/parallelogram tools available:

- **Center Rectangle**  - Uses a center point and corner to create a rectangle with horizontal and vertical lines.
  - **3 Point Center Rectangle**  - Creates a rectangle based on a center point, midpoint of edge and corner. Lines are perpendicular at corners.
  - **3 Point Corner Rectangle**  - Uses three corners to define a rectangle. Lines are perpendicular at corners.
  - **Parallelogram**  - Uses three corners to define a *parallelogram* (corners are not perpendicular).
- Where to Find It**
- CommandManager: **Sketch > Corner Rectangle** 
  - Menu: **Tools, Sketch Entities, Corner Rectangle**
  - Shortcut Menu: Right-click in the graphics area and click **Sketch Entities, Corner Rectangle** 

**3 Sketch a rectangle.**

Click **Corner Rectangle**  and begin the rectangle at the origin.

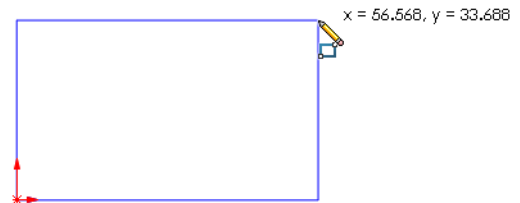

Make sure the rectangle is locked to the origin by looking for the coincident icon next to the cursor as you begin sketching. Do not worry about the size of the rectangle. Dimensioning it will take care of that in the next step.

**4 Fully defined sketch.**

Add dimensions to the sketch. The sketch is fully defined.

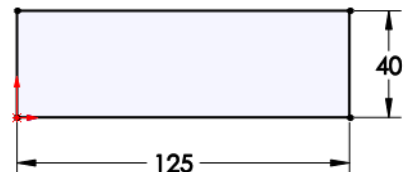

## Extrude Options

An explanation of some of the more frequently used **Extrude** options is given below (see *Extrude* on page 51). Other options will be discussed in later lessons.

### ■ End Condition Type

A sketch can be extruded in one or two directions. Either or both directions can terminate at some blind depth, up to some geometry in the model, or extend through the whole model.

### ■ Depth

The distance for a blind or mid-plane extrusion. For mid-plane, it refers to the total depth of the extrusion. That would mean that a depth of 50mm for a mid-plane extrusion would result in 25mm on each side of the sketch plane.

### ■ Draft

Applies draft to the extrusion. Draft on the extrusion can be inwards (the profile gets smaller as it extrudes) or outward.

---

## 5 Extrude.

Click **Extrude**  and extrude the rectangle **10mm** upwards. Click **OK**.

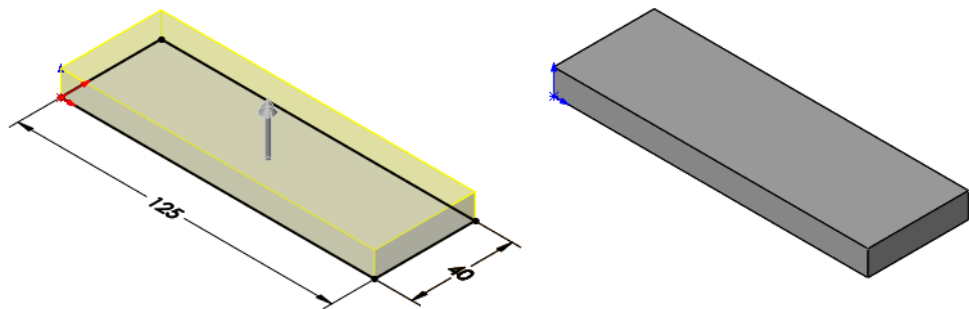

## Renaming Features

Any feature that appears in the FeatureManager design tree (aside from the part itself) can be renamed using the procedure below. Renaming features is a useful technique for finding and editing features in later stages of the model. Well chosen, logical names help you to organize your work and make it easier when someone else has to edit or modify your model.

## 6 Rename the feature.

It is good practice to rename important features that you create with some meaningful name. In the FeatureManager design tree, use a very slow double-click to edit the feature **Boss-Extrude1**. When the name is highlighted and editable, type **BasePlate** as the new feature name. All features in the SOLIDWORKS system can be edited in the same way.

## Tip

Instead of using a slow double-click to edit the name, you can select the name and press **F2**.

---

## Boss Feature

The next feature will be the boss with a curved top. The sketch plane for this feature will be a planar face of the model instead of an existing plane. The required sketch geometry is shown overlaid on the finished model.

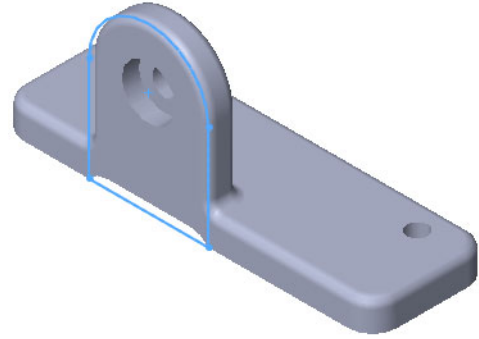

## Sketching on a Planar Face

Any planar (flat) face of the model can be used as a sketch plane. Simply select the face and click **Sketch** . Where faces are difficult to select because they are obscured by other faces, the **Select Other** tool can be used to choose a face without reorienting the view. In this case, the planar face on the front of the BasePlate is used.

### 7 Insert new sketch.

Select the indicated face and click **Sketch** .

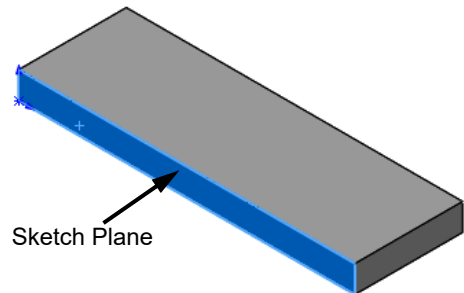

## Note

Make sure that **Features > Instant 3D**  is turned off. Leaving it on will cause several handles and axes that we are not currently using to appear on the face.



## Sketching

SOLIDWORKS offers a rich variety of sketch tools for creating profile geometry. In this example, **Tangent Arc** is used to create an arc that begins tangent to a selected endpoint on the sketch. Its other endpoint can be placed in space or on another sketch entity.

## Introducing: Tangent Arc

**Tangent Arc** is used to create tangent arcs in a sketch. The arc must be tangent to some other entity, line or arc, at its start.

## Where to Find It

- CommandManager: **Sketch > Arc**  > **Tangent Arc** 
- Menu: **Tools, Sketch Entities, Tangent Arc**
- Shortcut Menu: Right-click in the graphics area and click **Sketch Entities, Tangent Arc** 

## Tangent Arc Intent Zones

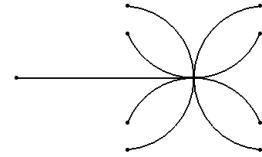

When you sketch a tangent arc, the SOLIDWORKS software infers from the motion of the cursor whether you want a tangent or normal arc. There are four intent zones, with eight possible results as shown.





You can start sketching a tangent arc from the end point of any existing sketch entity (line, arc, spline, and so on). Move the cursor away from the end point.

- Moving the cursor in a tangent direction creates one of the four tangent arc possibilities.
- Moving the cursor in a normal direction creates one of the four normal arc possibilities.
- A preview shows what type of arc you are sketching.
- You can change from one type of tangent arc to the other by returning the cursor to the endpoint and moving away in a different direction.

## Autotransitioning Between Lines and Arcs

When using **Line** , you can switch from sketching a line to sketching a tangent arc, and back again, without clicking **Tangent Arc** . You can do this by returning the cursor to the endpoint and moving away in a different direction or by pressing the **A** key on the keyboard.

### 8 Vertical line.

Click **Line**  and start the vertical line at the lower edge capturing a **Coincident**  relation at the lower edge and **Vertical** relation .

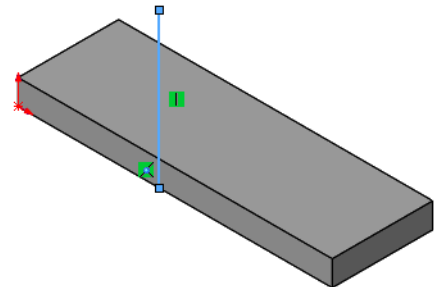

### 9 Autotransition.

Move the cursor back to the endpoint and move away in a different direction. You are now in tangent arc mode.

### 10 Tangent arc.

Sketch a 180° arc tangent to the vertical line. Look for the inference line indicating that the end point of the arc is aligned horizontally with the arc's center.

When you finish sketching, the sketch tool automatically switches back to the line tool.

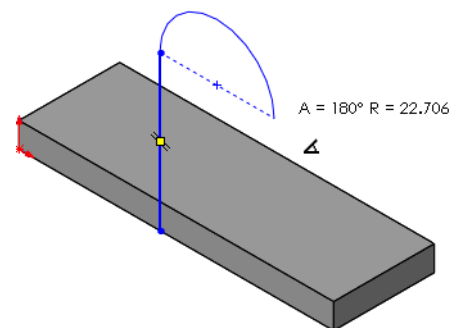

**11 Finishing lines.**

Create a vertical line from the arc end to the base, and one more line connecting the bottom ends of the two vertical lines.

Note that the horizontal line is black, but its endpoints are not.

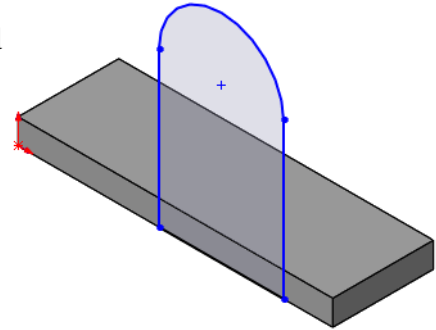
**12 Add dimensions.**

Add linear and radial dimensions to the sketch.

As you add the dimensions, move the cursor around to view different possible orientations.

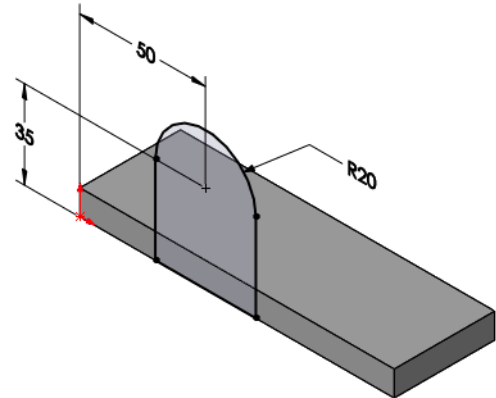

Always dimension to an arc by selecting on its circumference, rather than center. This makes other dimensioning options (min and max) available.

**13 Extrude direction.**

Click **Extrude**  and set the **Depth** to **10mm**. Note that the preview shows the extrusion going into the base, in the proper direction.

If the direction of the preview is away from the base, click

**Reverse Direction** .

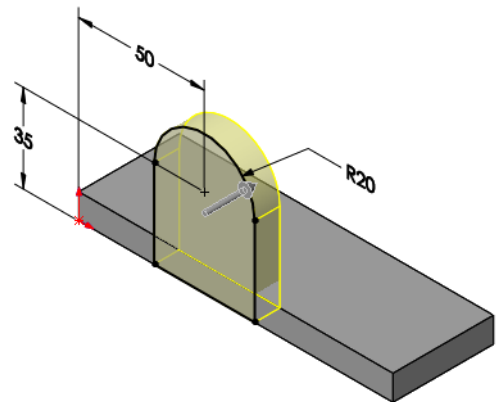
**Note**

When using the **Spin Increment** arrows, the default up and down increment is 10mm. Pressing the **Alt** key with an arrow drops it to 1/10X, or 1mm. Using it with **Ctrl** key it increases it 10X to 100mm.

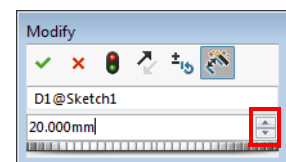

**14 Completed boss.**

The boss merges with the previous base to form a single solid.

Rename the feature VertBoss.

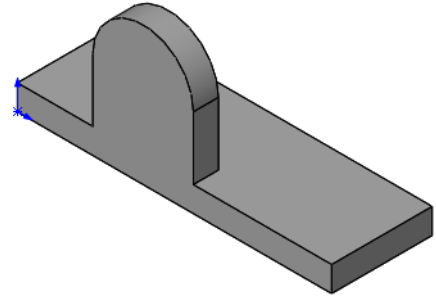

---

---

**Cut Feature**

Once the two main boss features are completed, it is time to create a cut to represent the removal of material. Cut features are created in the same way as bosses - in this case with a sketch and extrusion.

**Introducing:  
Cut Extrude**

The menu for creating a cut feature by extruding is identical to that of creating a boss. The only difference is that a cut removes material while a boss adds it. Other than that distinction, the commands are the same. This cut represents a slot.

**Where to Find It**

- CommandManager: **Features > Extruded Cut** 
- Menu: **Insert, Cut, Extrude**

---

---

**15 Rectangle.**

Press **Space bar** and click **Front** . Start a sketch on this large face and add a rectangle **Coincident** with the bottom model edge.

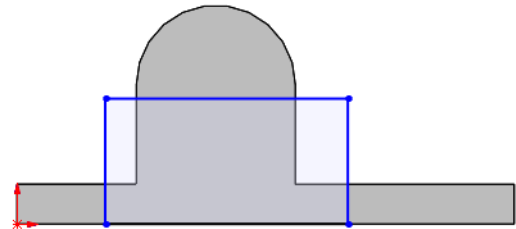

Turn off the rectangle tool.

**16 Dimensions.**

Add a dimension as shown.

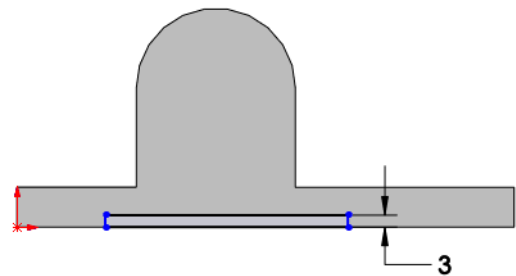

**Note**

The sketch is under defined, but it will be made fully defined later in this lesson. See *Status of a Sketch* on page 38.

---

---

## View Selector



The **View Selector** helps to visualize how views of the model will appear by using a transparent cube surrounding the model.

Select a face of the cube to look at the model through the cube, normal to that face or select a view orientation by name.

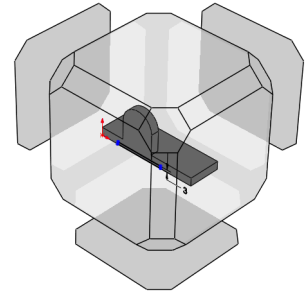
The cube can also be rotated prior to selecting a face.



### Where to Find It

- Heads-up View Toolbar: **View Orientation**  and **View Selector** 
- Keyboard Shortcut: **Space bar**

### Note

Pressing the **Space Bar** opens the **View Selector** and the **Orientation** dialog box. Pressing **Ctrl+Space bar** opens *only* the **View Selector**.

### 17 View Selector.

Press **Space Bar** and click the corner of the cube that is labeled Isometric.

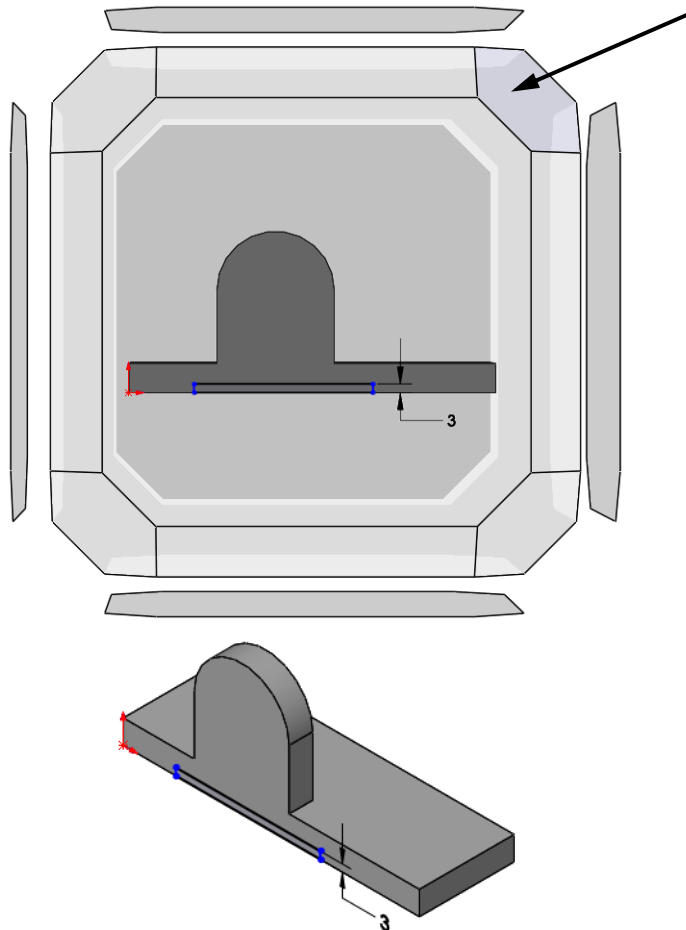

### 18 Through All Cut.

Click **Extruded Cut** . Choose **Through All** and click **OK**. This type of end condition always cuts through the entire model no matter how far. No depth setting was needed. Rename the feature BottomSlot.

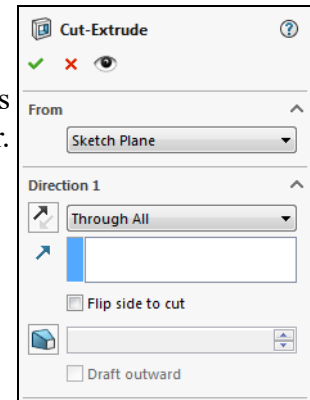
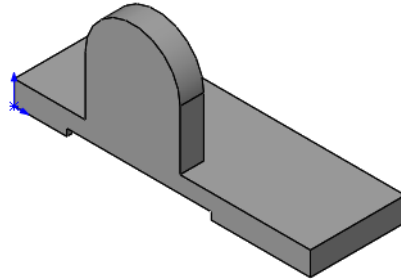

---

## Using the Hole Wizard

The **Hole Wizard** is used to create specialized holes in a solid. It can create simple, tapered, counterbored and countersunk holes using a step by step procedure. In this example, the **Hole Wizard** will be used to create a standard hole.

### Creating a Standard Hole

You can choose the face to insert the hole onto, define the hole's dimensions and locate the hole using the **Hole Wizard**. One of the most intuitive aspects of the **Hole Wizard** is that you specify the size of the hole by the fastener that goes into it.

### Tip

You can also place holes on planes and non-planar faces. For example, you can create a hole on a cylindrical face.

### Counterbore Hole

A counterbore hole is required in this model. Using the front face of the model and a relation, the hole can be positioned.

### Note

The **Advanced Hole Wizard (Insert, Features, Advanced Hole)** is similar to the Hole Wizard, but allows you to design a stack of hole styles including counterbores, countersinks, tapered, tapped, and standard holes.

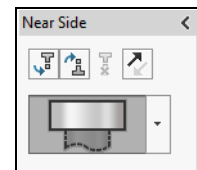

### Introducing: The Hole Wizard

The **Hole Wizard** creates shaped holes, such as countersunk and counterbore types. The process creates two sketches. One defines the shape of the hole. The other, a point, locates the center.

### Where to Find It

- CommandManager: **Features > Hole Wizard** 
- Menu: **Insert, Features, Hole Wizard**

**19 Select Counterbore.**

Select the face indicated and click **Hole**

**Wizard** . Set the properties of the hole as follows:

**Type: Counterbore**

**Standard: ANSI Metric**

**Type: Hex Bolt - ANSI B18.2.3.5M**

**Size: M8**

**End Condition: Through All**

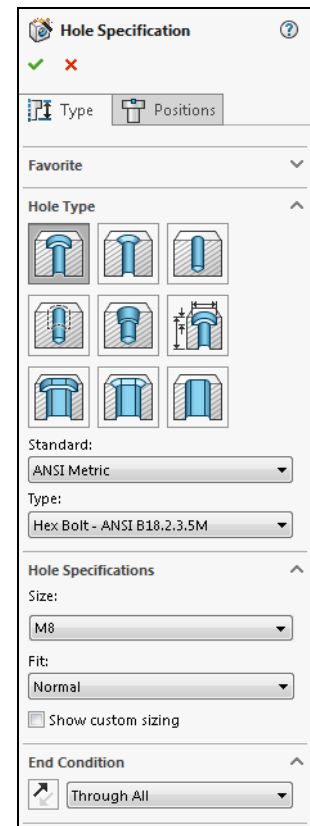
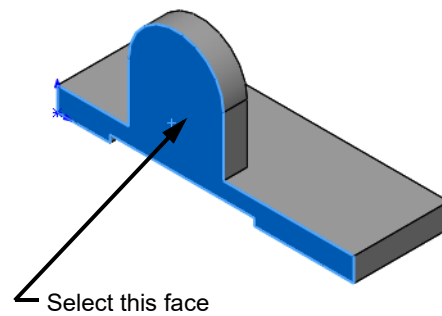
**20 Wake up the centerpoint.**

Click the **Positions** tab.

Hover the cursor over the circumference of the large arc. *Do not click.*

When the **Coincident** symbol appears , the center point of the large arc has been “woken up” and is now a point you can snap to.

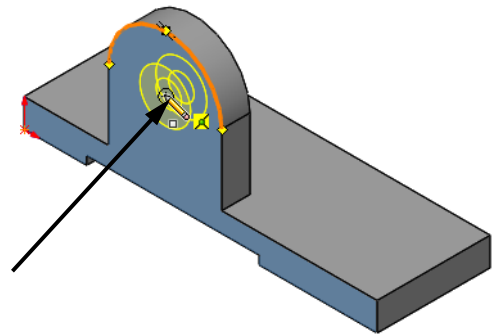

Click the point onto the arc’s centerpoint. Look for the feedback that tells you that you are snapping to the arc’s center, a coincident relation. Click **OK** to complete the dialog.

## Filleting

Filleting refers to both fillets (adding volume) and rounds (removing volume). The distinction is made by the geometric conditions, not the command itself. Fillets are created on selected edges of the model. Those edges can be selected in several ways, and several options exist for creating different fillet types including constant size, variable size, face and full round fillets. Fillet profile options include circular, conic and curvature continuous.

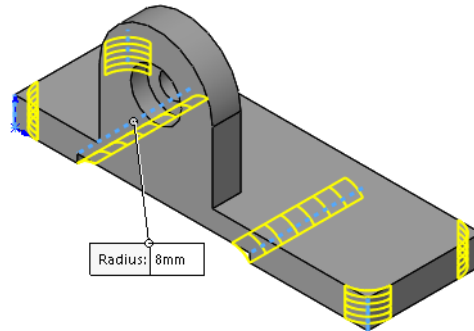

### Note

See the *Advanced Part Modeling* course for more information on fillet types and options.

### Filleting Rules

Some general filleting rules are:

1. Leave cosmetic fillets until the end.
2. Create multiple fillets that will have the same radius in the same command.
3. When you need fillets of different radii, generally you should make the larger fillets first.
4. Fillet order is important. Fillets create faces and edges that can be used to generate more fillets.
5. Existing fillets can be converted to chamfers (see *Chamfers* on page 175).

### Selection Toolbar

The **Selection Toolbar** can be used to turn a single edge selection into multiple, related, selections. It will not be used in this example, but it will be explained in *Edge Selection* on page 173.





### Preview

You have a choice between **Full preview**, **Partial preview** and **No preview** of the fillet. **Full preview**, as shown in the following images, generates a mesh preview on each selected edge. **Partial preview** only generates the preview on the first edge you select. As you gain experience with filleting, you will probably want to use **Partial** or **No preview** because they are faster.

## Where to Find It

- CommandManager: **Features > Fillet** 
- Menu: **Insert, Features, Fillet/Round**
- Shortcut Menu: Right-click a face or edge and click **Fillet** 

**21 Insert Fillet.**

Click **Fillet** . Click **Manual**, click **Constant Size Fillet**  and set the radius value to **8mm**.

Clear **Show selection toolbar** and click **Full preview**.

**22 Select edge.**

Select the two hidden edges shown through the model as shown.

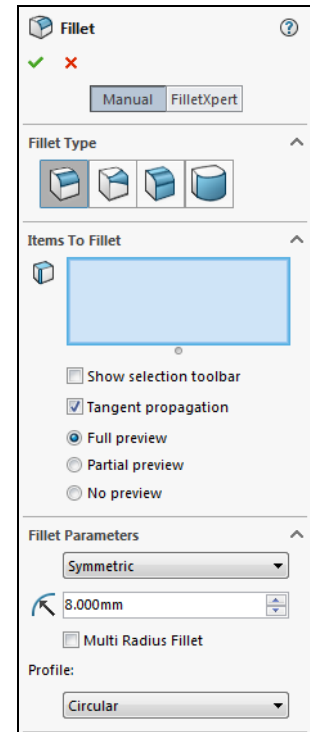
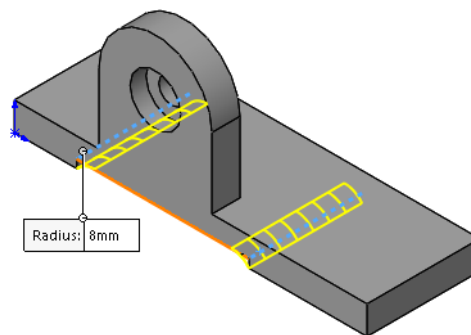
**23 Additional selections.**

Select the additional four corner edges as shown and click **OK**.

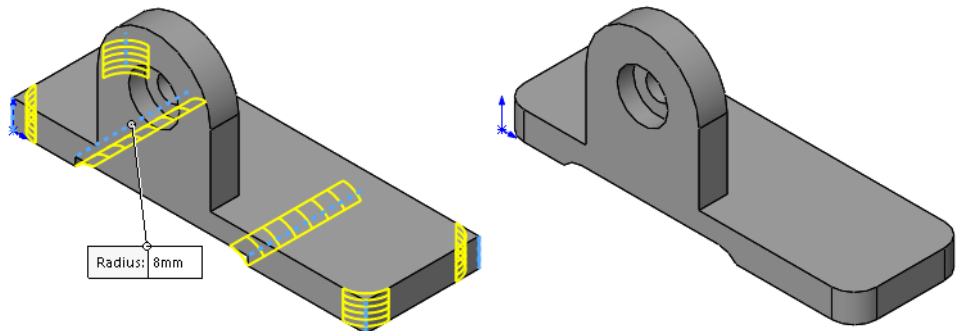
**Note**

All six fillets are controlled by the same dimension value. The creation of these fillets has generated new edges suitable for the next series of fillets.

## Recent Commands

SOLIDWORKS provides a “just used” buffer that lists the last few commands for easy reuse. The **Enter** key can also be used to re-launch the last used command.

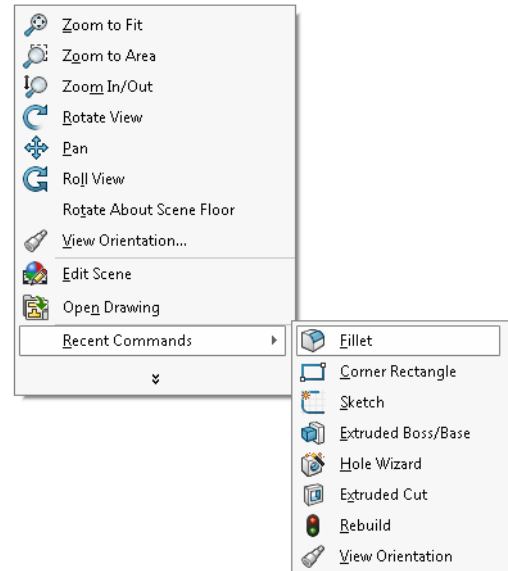

## Recent Features

The History folder contains a list of the most recent features that have been created or edited. This is useful for getting access to recent features. See *Editing Tools* on page 81 for more information.

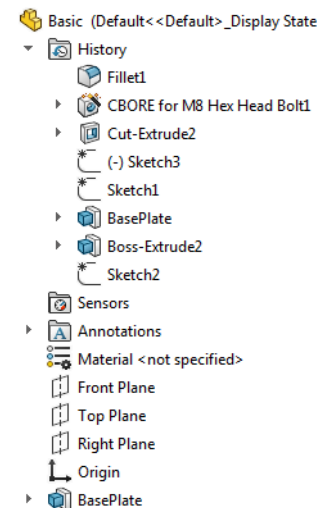

### 24 Recent Command.

Right-click in the graphics area and click **Recent Commands** and the **Fillet** command from the drop-down list to use it again.

### 25 Preview and propagate.

Add another fillet, radius **3mm**, using **Full preview**.

Select the edges indicated to see the selected edges and preview.

Click **OK**.

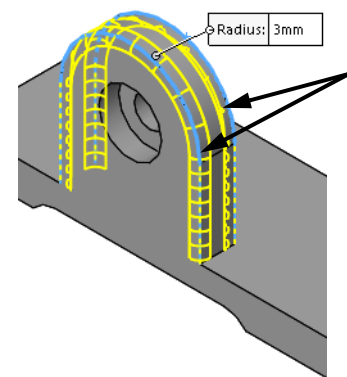

## Editing Tools

Three of the most common editing tools are introduced in this lesson: **Edit Sketch**, **Edit Feature** and **Rollback**. They can be used to edit and repair sketches and features as well as specify where, in the FeatureManager design tree, the features are to be created.

### Tip

The other editing tools are found later in this lesson: *Editing Features* on page 82 and *Rollback Bar* on page 82.

## Editing a Sketch

Once created, sketches can be changed using **Edit Sketch**. This opens the selected sketch so that you can change anything: the dimension values, the dimensions themselves, the geometry or geometric relations.

### Introducing: Edit Sketch

**Edit Sketch** enables you to access a sketch and make changes to any aspect of it. During editing, the model is “rolled back” to its state at the time the sketch was created. The model will be rebuilt when the sketch is exited.

### Where to Find It

- Shortcut Menu: Right-click a sketch or feature and click **Edit Sketch** 
- Menu: Select a face and click **Edit, Sketch**

### 26 Edit the sketch.

Right-click the BottomSlot feature and click **Edit Sketch** . The existing sketch will be opened for editing.

### Selecting Multiple Objects

As you learned in *Selecting Multiple Objects* on page 45, when selecting multiple objects, hold down the **Ctrl** key and then select the objects.

### 27 Relations.

Select the endpoint and edge as shown and add a **Coincident** relation.

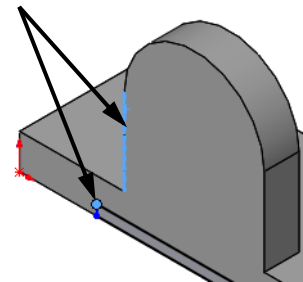

### 28 Repeat.

Repeat the procedure for the endpoint at the other end of the rectangle as shown. The addition of these relations will fully define the sketch.

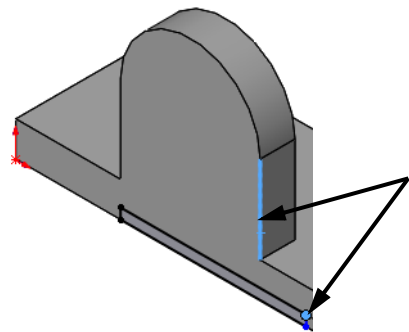

**Note** For more information about relations, see *Sketch Relations* on page 41.

**29 Exit the sketch.**

Click **Exit Sketch**  in the upper right (confirmation) corner to exit the sketch and rebuild the part.

---

**Editing Features**

The second fillet should also be applied to the top edges of the Base Plate. To do this we will edit the definition of the last fillet feature.

**Introducing:  
Edit Feature**

**Edit Feature** changes how a feature is applied to the model. Each feature has specific information that can be changed or added to, depending on the type of feature it is. As a general rule, the same dialog box used to create a feature is used to edit it.

**Fillet Propagation**

The **Tangent Propagation** checkbox within the **Fillet** tool allows a fillet feature to flow to tangent edges of the selections made.

**Where to Find It**

- Menu: Select a feature and click **Edit, Definition**
- Shortcut Menu: Right-click a feature and click **Edit Feature** 

---

**30 Edit the feature.**

Right-click the **Fillet2** feature and click **Edit Feature** . The existing feature will be opened for editing using the same PropertyManager that was used to create the feature. Make sure that **Tangent Propagation** is clicked.

**31 Select additional edge.**

Select the additional short edge as shown and the propagation will create the fillets as shown. Click **OK**.

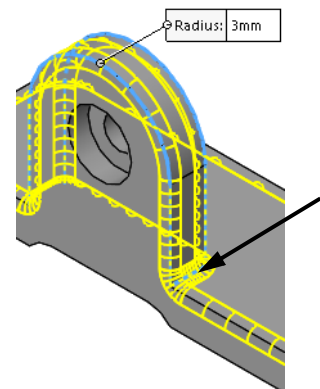

---

**Rollback Bar**

The **Rollback Bar** is the blue horizontal bar located at the bottom of the FeatureManager design tree.

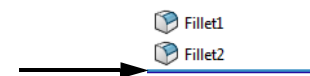

The **Rollback Bar** has many uses. It can be used to “walk through” a model showing the steps that were followed to build it or to add features at a specific point in the part’s history. In this example, it will be used to add a hole feature between the existing fillet features.

**Using Rollback with Large Parts**

The **Rollback Bar** is also useful when editing large parts to limit rebuilding. Roll back to the position just after the feature that you are editing. When the editing is completed, the part is rebuilt only up to the rollback bar. This prevents the entire part from being rebuilt. The part can be saved in a rollback state.

**Introducing: The Rollback Bar**

You can roll back a part using the **Rollback Bar** in the FeatureManager design tree. The rollback bar is a line which highlights when selected. Drag the bar up or down the FeatureManager design tree to step forward or backward through the regeneration sequence.

**Note**

To move the rollback bar with the arrow keys, click **Tools, Options, System Options, FeatureManager, Arrow key navigation**. The focus must be set to the rollback bar by clicking on it. If the focus is set to the graphics area, the arrow keys will rotate the model.

**Where to Find It**

- Shortcut Menu: Right-click a feature and click **Rollback** ↩
- Shortcut Menu: Right-click in the FeatureManager design tree and click **Roll to Previous** or **Roll to End**

**32 Rollback.**

Click on the **Rollback Bar** and drag it upwards. Drop it before the fillet features as shown.

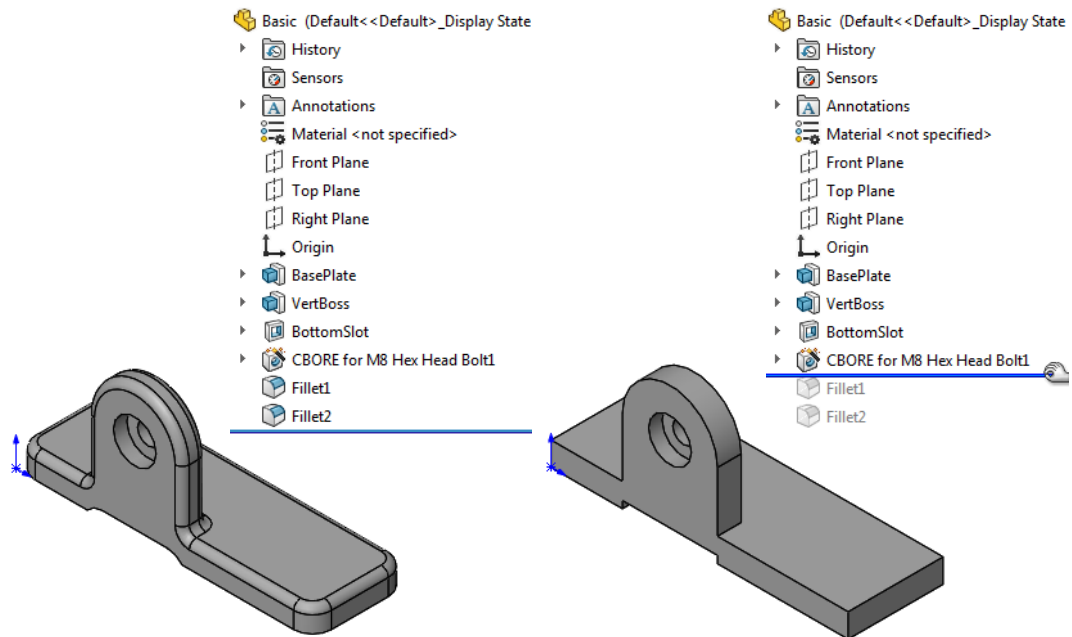

**33 Hole Wizard.**

Click the **Hole Wizard**  and click the **Positions** tab.

**34 Face selection.**

Select the face indicated.

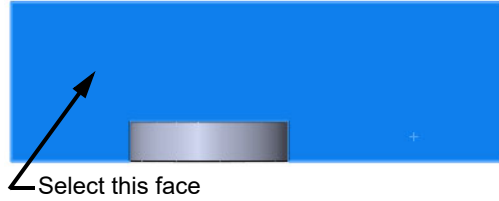

**35 Holes.**

Add two points and dimension them as shown.

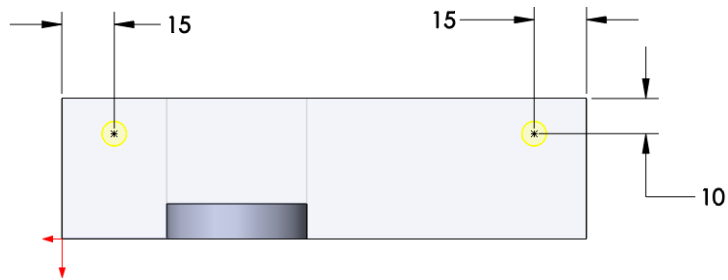

**36 Type.**

Click the Type tab and set the properties of the hole as follows. Click **OK**.

**Type: Hole**

**Standard: Ansi Metric**

**Type: Drill sizes**

**Size: 7.0**

**End Condition: Through All**

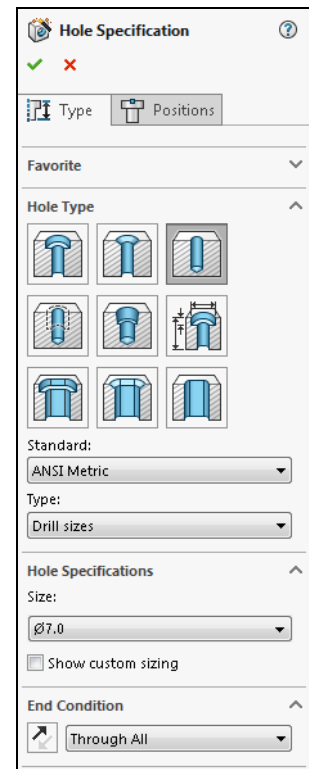

**37 Change the view orientation.**

Click **Isometric**  to change view orientation.

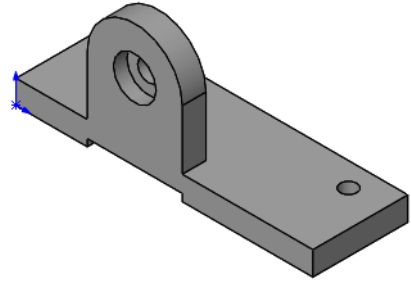
**38 Roll to end.**

Right-click on the rollback bar and click **Roll to End**.

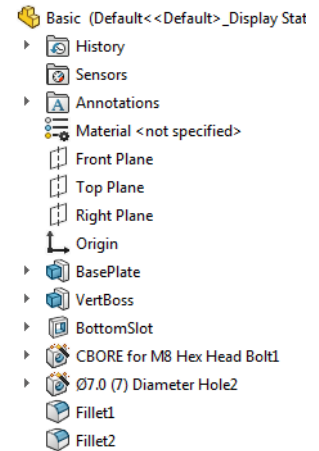
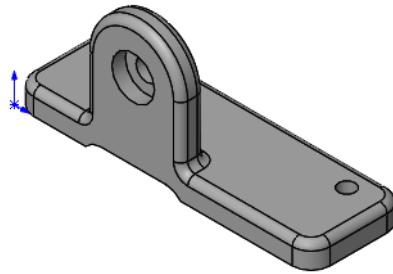
**Introducing:  
Appearances**

Use **Appearances** to change the color and optical properties of graphics. Color **Swatches** can also be created for user defined colors.

**Where to Find It**

- Shortcut Menu: Right-click a face, feature, body, part, or component, click **Appearances**, and click the item to edit
- Heads-up View Toolbar: **Edit Appearance** 



### 39 Select swatch.

Click **Edit Appearance** . Under the **Color** selection, select the **standard** swatch and one of the colors as shown.

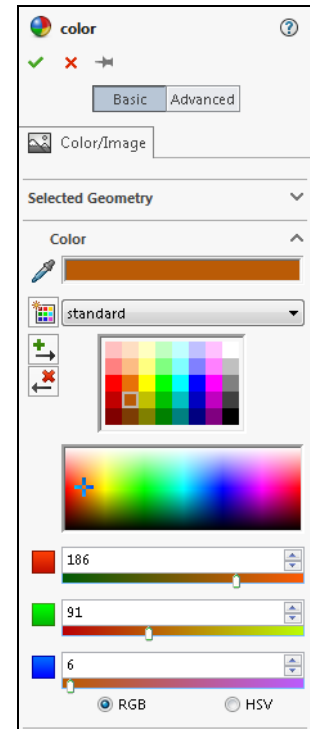
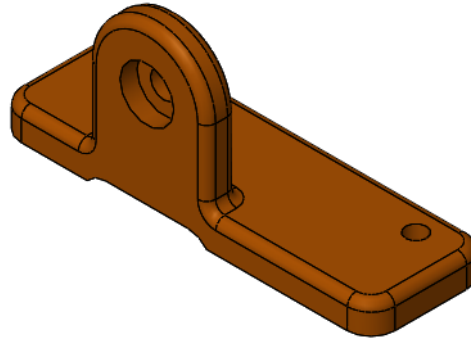
Click **OK**.



### 40 Display appearances.

Click the DisplayManager  tab to see the color listed. Click the FeatureManager design tree  tab.

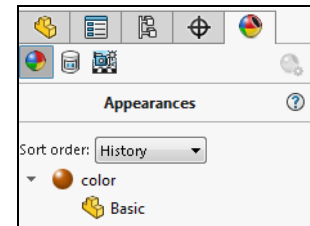

#### Tip

The DisplayManager can also be used to view and modify decals, scenes, lights and cameras.

#### A Note About Color in the User Interface

You can customize the colors of the SOLIDWORKS user interface. This is done through **Tools, Options, System Options, Colors**. You can select predefined color schemes, or create your own. In some cases, we have altered colors from their default settings to improve clarity and reproduction quality. As a result, the colors on your system may not match the colors used in this book.

### 41 Save the results.

Click **Save**  to save your work.

## Detailing Basics

SOLIDWORKS enables you to easily create drawings from parts or assemblies. These drawings are fully associative with the parts and assemblies they reference. If you change the model, the drawing will update.

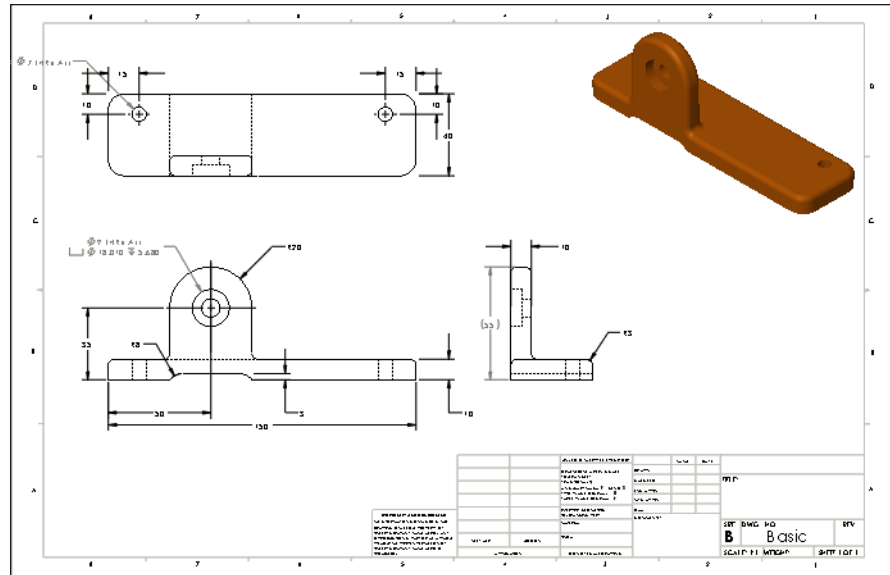

Various topics related to making drawings are integrated into several lessons throughout this book. The material presented here is just the beginning. Specifically:

- Creating a new drawing file and sheet.
- Creating drawing views using the View Palette.
- Using dimension assist tools.

A comprehensive treatment of detailing is offered in the course *SOLIDWORKS Drawings*.

## Settings Used in the Template

The drawing template used in this section has been designed to include the **Document Properties** shown in the chart below. Settings are accessed through **Tools, Options**. The settings that will be used in this lesson are:

System Options	Document Properties (Set using drawing template)
Drawings, Display Style: <ul style="list-style-type: none"> <li>• <b>Display style for new views = Hidden lines removed</b></li> <li>• <b>Tangent Edges = Visible</b></li> </ul>	Drafting Standard: <ul style="list-style-type: none"> <li>• <b>Overall drafting standard = ANSI</b></li> </ul>
Colors: <ul style="list-style-type: none"> <li>• <b>Drawings, Hidden Model Edges = Black</b></li> </ul>	Dimensions: <ul style="list-style-type: none"> <li>• <b>Font = Century Gothic</b></li> <li>• <b>Primary precision = .123</b></li> <li>• <b>Add parentheses by default = Selected</b></li> </ul>
	Detailing, Auto insert on view creation: <ul style="list-style-type: none"> <li>• <b>All options = cleared</b></li> </ul>
	Units <ul style="list-style-type: none"> <li>• <b>Unit system =MMGS</b></li> </ul>

## CommandManager Tabs

When working in a drawing document, the CommandManager tabs will update to include toolbars that are specific to the process of detailing and making drawings. They are:

### ■ Drawing



### ■ Annotation



## New Drawing

Drawing files (\*.SLDDRW) are SOLIDWORKS files that contain drawing sheets. Each sheet is the equivalent of a single sheet of paper.

## Introducing: Make Drawing from Part

**Make Drawing from Part** takes the current part and steps through the creation of a drawing file, sheet format and initial drawing views using that part.

## Where to Find It

- Menu Bar: **New** , **Make Drawing from Part/Assembly** 
- Menu: **File, Make Drawing from Part**

## 1 Create Drawing.

Click **Make Drawing from Part/Assembly**  and choose B\_Size\_ANSI\_MM from the **Training Templates** tab.

The sheet format creates a B-size drawing (11" x 17") arranged with its long edge horizontal. The sheet format includes a border, title block, and other graphics.

### Tip

Double-clicking the template will automatically open it, eliminating the need to click **OK**.

## Drawing Views

The initial task of detailing is the creation of views. Using the **Make Drawing from Part/Assembly** tool leads you through the selection of the drawing sheet to the **View Palette**. Previews of the model orientations are shown in the lower pane of the View Palette. Create views on the drawing sheet by using a drag and drop procedure. Additional views can be projected or folded directly from the dropped view.

These options are discussed in detail in the *SOLIDWORKS Drawings* course.

## 2 View Palette.

Clear **Import Annotations**. Drag the Front view from the **View Palette** and drop it onto the drawing as shown.

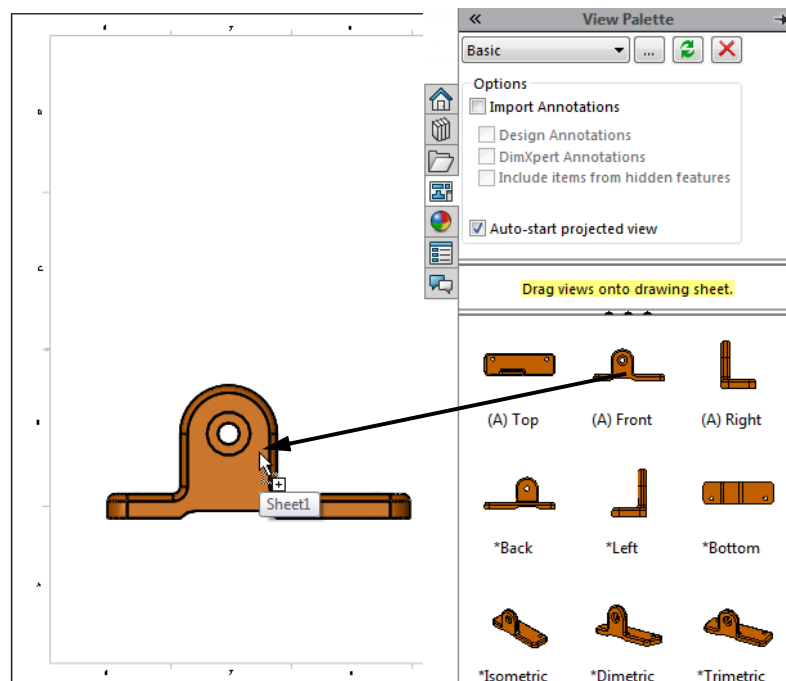

### 3 Projected views.

Once the first view is placed, **Projected View** become active. Add the Top view by moving the cursor above the view and clicking.

Return the cursor to the Front view and move to the right to create the Right view. Click **OK**.

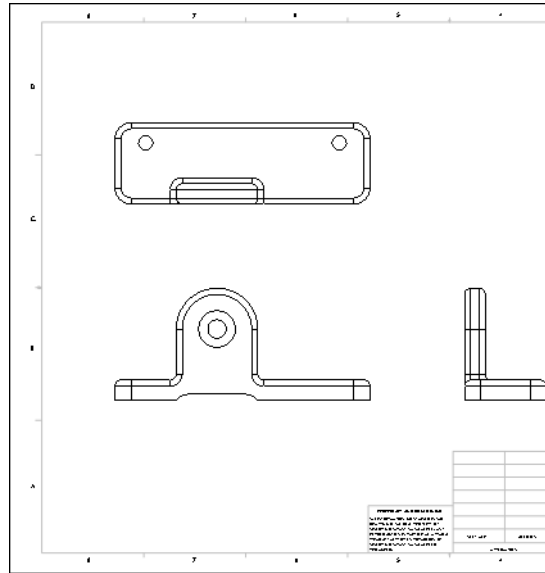

### 4 Drawing views.

Add the \*Isometric view by dragging and dropping from the palette. Place it in the upper right corner.

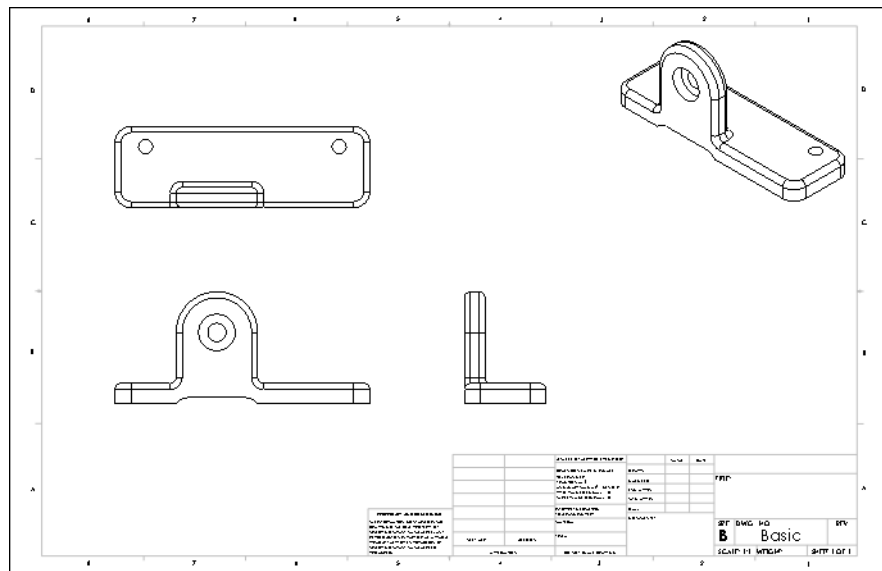

#### Note

The part document is still open. You can press **Ctrl+Tab** to switch between the drawing and part document windows.

## Tangent Edges

**Tangent Edges** are topological edges of faces that match in tangency. The most commonly seen tangent edges are the edges of fillets. They are often made visible in pictorial views but are removed from orthographic views.

### Where to Find It

- Shortcut Menu: Right-click the view and click **Tangent Edge**

#### 5 Remove tangent edges.

Using the **Control** key, select the front, top, and right views. Click **Tangent Edge** and **Tangent Edges Removed**.

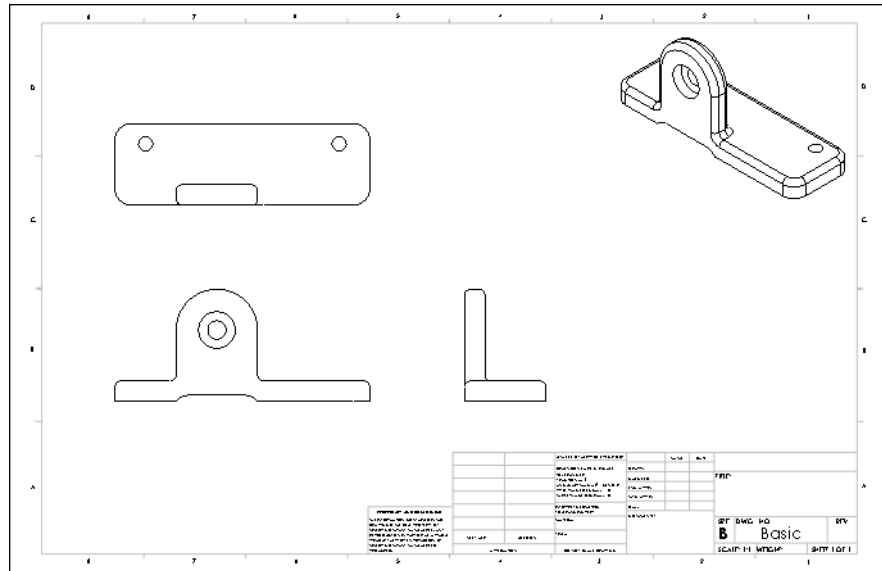

#### 6 Display style.

Click the Isometric view and click **Shaded** . In the other views, click **Hidden Lines Visible** .

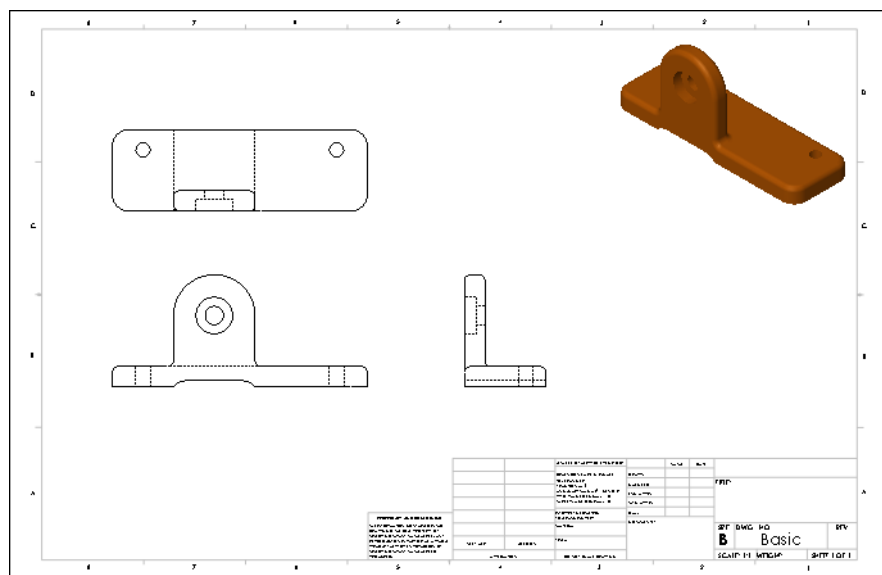

## Moving Views

Drawing views can be repositioned on the drawing. You place your pointer over the view border, then drag the view. In the standard 3 view arrangement, the Front view is the *source* view. This means that moving the front view moves all three views. The Top and Right views are *aligned* to the Front. They can only move along their axis of alignment.

### 7 Move Aligned Views.

Select the edge and move the Front view. It can be moved in any direction and the other views remain aligned.

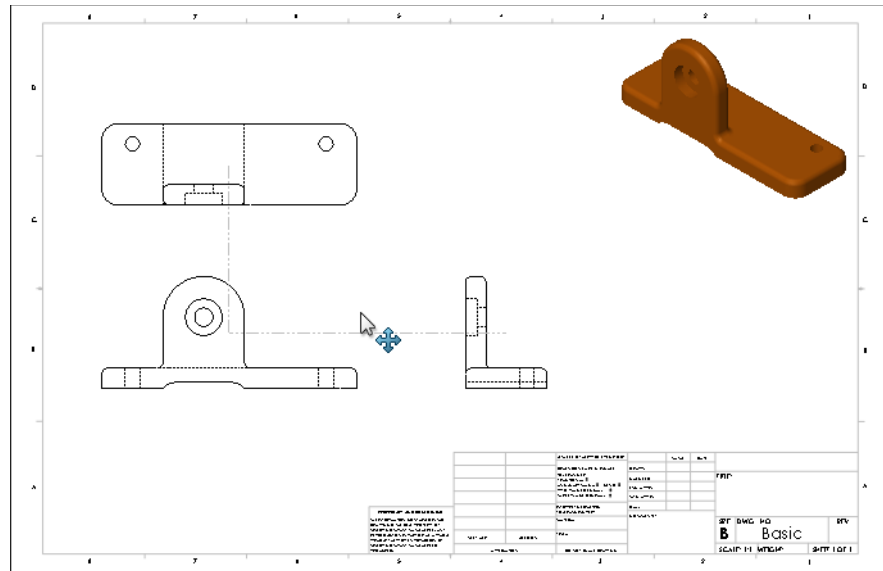

### Note

Once the drawing view has been selected, it can be dragged with the mouse or moved with the arrow keys. The distance moved for each press of an arrow key is set under **Tools, Options, System Options, Drawings, Keyboard movement increment**. Use **Alt-drag** to select anywhere in the view. Use **Shift-drag** to maintain the spacing between the views while dragging.

## Center Marks

**Center Marks** are attached to circle and arc centers in the drawing view.

Center marks were not inserted into the drawing views automatically. You can turn this option on or off. Set your preference using the **Tools, Options, Document Properties, Detailing** menu.

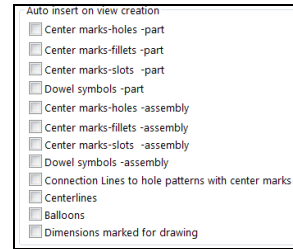

### Where to Find It

- CommandManager: **Annotation > Center Mark** 
- Menu: **Insert, Annotations, Center Mark**
- Shortcut Menu: Right-click in the graphics area and click **Annotations, Center Mark**

### 8 Center Mark.

Click **Center Mark** .

Clear **Use document defaults**, check the **Extended lines** option and set the **Mark size** to **2mm** as shown.

Click the large arc in the front view. Continue adding center marks to the two holes in the Top view.

Click **OK**.

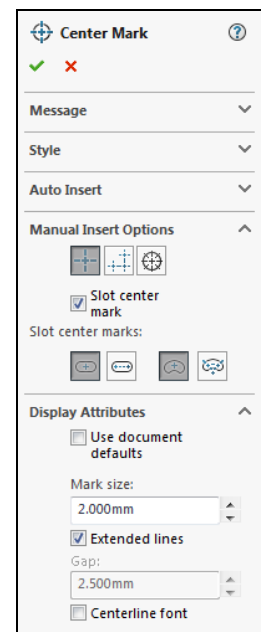
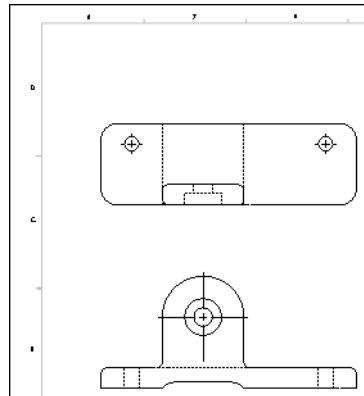

## Dimensioning

Dimensions can be created in drawing views using several tools. Some dimensions can be related to the dimensions generated in the sketches and features of the model. These are *driving* dimensions. Other dimensions are independent of the sketches and features of the model. These are *driven* dimensions.

### Driving Dimensions

Driving dimensions always display the proper values and can be used to change the model. The **Model Items** tool imports the dimensions created in the sketches and features of the model into the drawing.

### Driven Dimensions

Driven dimensions always display the proper values but cannot be used to change the model. The values of driven dimensions change when the model dimensions change. By default, dimensions of this type appear in a different color and are enclosed in parentheses. Here are two ways to create driven dimensions:

- The **Smart Dimension** tool manually adds dimensions to the model like those in a sketch.
- The **DimXpert** tool adds dimensions working from a datum position.

### Introducing: Model Items

The **Model Items** tool assists in adding dimensions to a view or all views using the sketch and feature dimensions of the model.

You can import the dimensions for a selected feature or the entire model. It also has the capability to select and import different types of dimensions as well as many types of **Annotations** and **Reference Geometry** that may exist within the model.

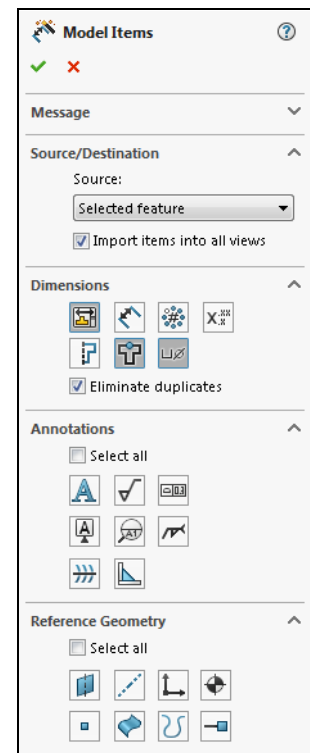

### Where to Find It

- CommandManager: **Annotation > Model Items** 
- Menu: **Insert, Model Items**

**9 Model items.**

Click **Model Items** . Click **Entire Model** as the **Source** and **Import items into all views**.

Under **Dimensions**, click **Marked for drawing**, **Hole Wizard Locations**, **Hole callout** and **Eliminate duplicates**.

Click **OK**.

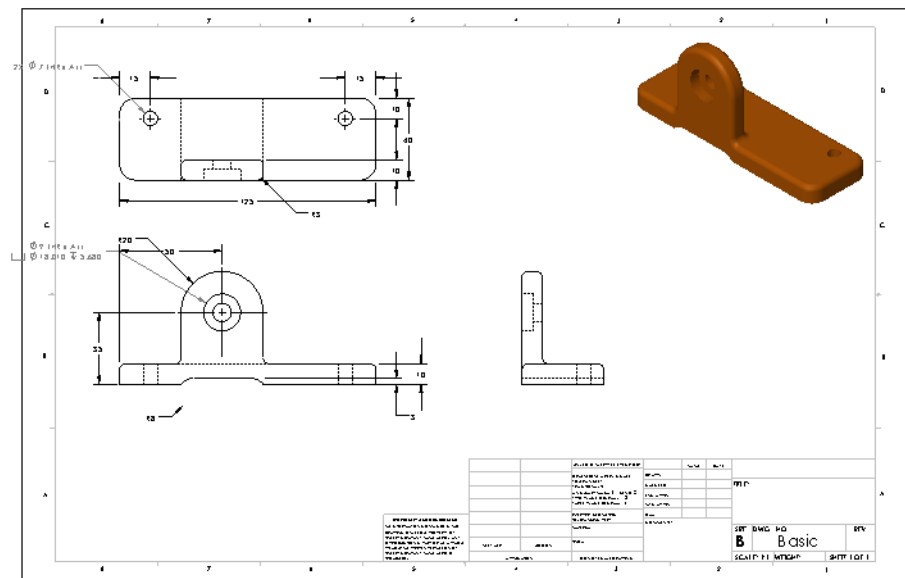
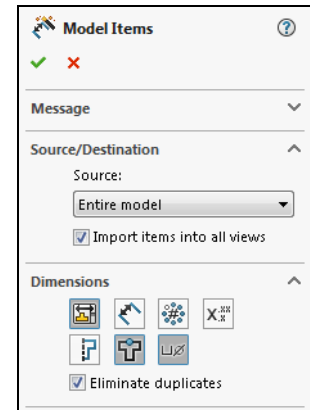
**Note**

The position of a dimension depends on how the feature was created and where the model dimension was placed. Your results may vary from the image above.

**Tip**

Once the dimensions are inserted, they are associated to that view and will move with it unless you deliberately move them to another view or delete them. For more information, see *Manipulating Dimensions* on page 96.

## Manipulating Dimensions

Once dimensions have been added to a view, there are several options as to how they can be manipulated:

<b>Drag</b>	Drag dimensions by their text to new locations. Use the inference lines to align and position them.
<b>Hide</b>	Right-click the dimension text and click <b>Hide</b> from the shortcut menu.
<b>Move to another view</b>	There is generally more than one view where a dimension can be used. To move a dimension, <b>Shift</b> + drag the dimension onto another view.
<b>Copy to another view</b>	To copy the dimension, hold down <b>Ctrl</b> and drag it into another view and drop it.
<b>Delete</b>	Unwanted dimensions can be deleted from the drawing using the <b>Delete</b> key.

### 10 Drag dimensions.

Drag dimensions within the view to reposition them as shown.

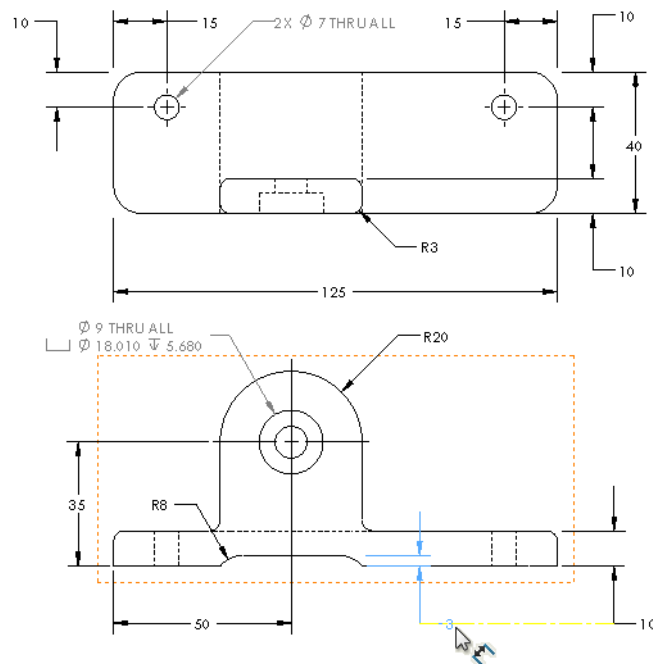

### Tip

Align dimension text using the yellow guidelines.

**11 Move to another view.**

**Shift + drag the 125mm dimension to Drawing View1 and drop it. It will be moved from the original view to the new view.**

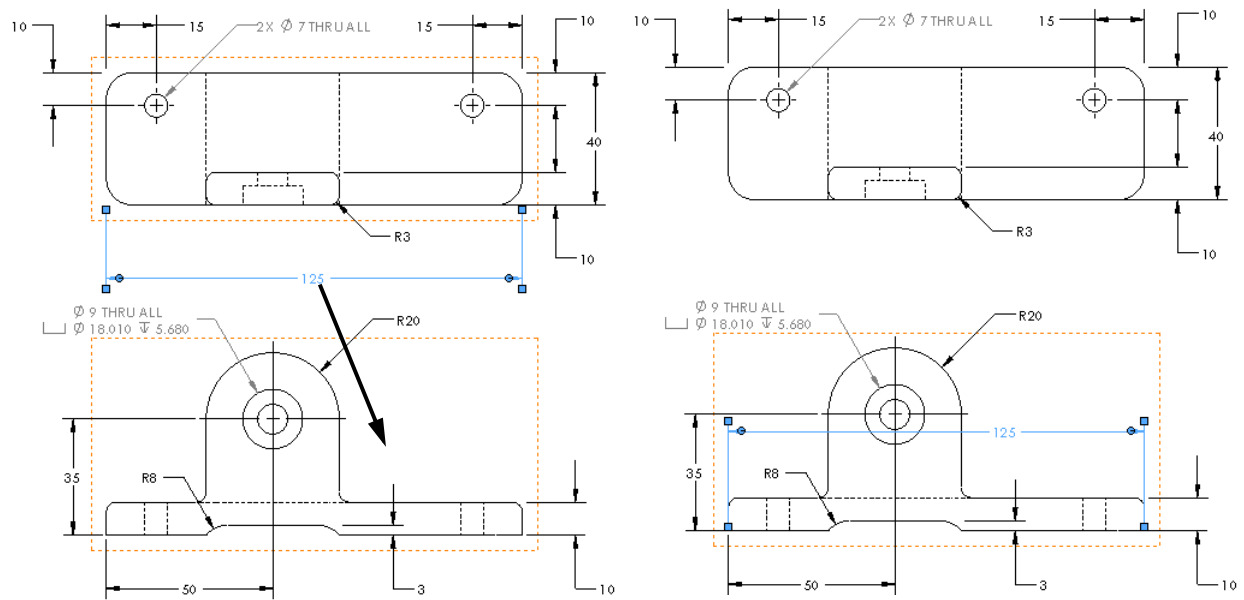

**12 Move remaining dimensions.**

Move dimensions to reposition them as shown.

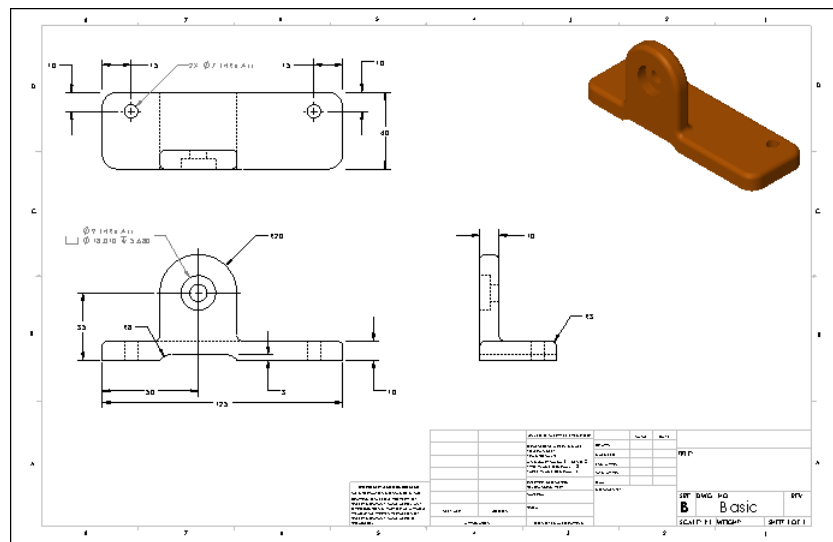

## Dimension Palette

The **Dimension Palette** appears near your cursor when you insert a dimension or select one or more dimensions. It can be used to change the dimensions' properties, formatting, position, and alignment.

## Where to Find It



- Select one or more dimensions then click 

## Dimension Assist Tool - Smart Dimensioning

Use the **Smart dimensioning** option of the dimension assist tool to manually add dimensions in the drawing. These dimensions are considered to be *driven* dimensions. See *Driven Dimensions* on page 94.

---

### 13 Arrange the dimensions.

Select all of the dimensions in the top view and click  to open the **Dimension Palette**. Then, click **Auto Arrange Dimensions**  to provide better spacing and alignment of the dimensions.

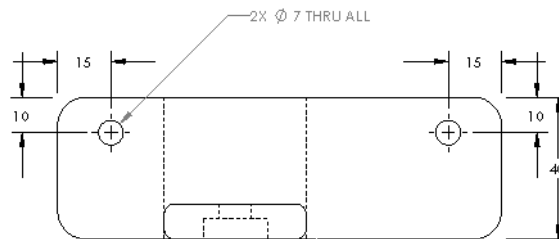

## Note

Adjustments can be made to dimensions after using arrange.

### 14 Dimensioning.

Click **Smart Dimension** . Select vertices at the top and bottom and place the dimension to the left of the view.

Click **OK**.

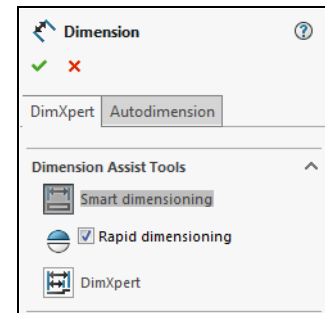
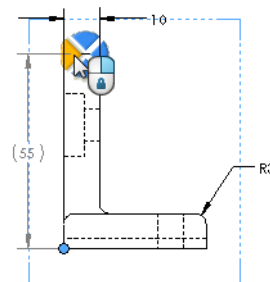

**Associativity  
Between the Model  
and the Drawing**

In the SOLIDWORKS software, everything is associative. If you make a change to an individual part, that change will propagate to any and all drawings and assemblies that reference it.

**15 Switch windows.**

Press **Ctrl+Tab** and click the part file to switch back to the part document window.

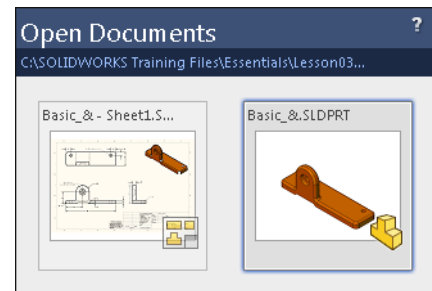
**Changing  
Parameters**

SOLIDWORKS makes it very easy to make changes to the dimensions of your part. This ease of editing is one of the principal benefits of parametric modeling. It is also why it is so important to properly capture your design intent. If you don't properly capture the design intent, changes to dimensions may cause quite unexpected results in your part.

**Rebuilding the  
Model**

After you make changes to the dimensions, you must rebuild the model to cause those changes to take affect.

**Rebuild Symbol**

If you make changes to a sketch or part that require the part to be rebuilt, a rebuild symbol  is displayed beside the part's name as well as superimposed on the icon of the feature that requires rebuilding

 BasePlate . Look for the rebuild icon on the Status Bar, also.

The rebuild symbol also is displayed when you are editing a sketch. When you exit the sketch, the part rebuilds automatically.

**Introducing: Rebuild**

**Rebuild** regenerates the model with any changes you have made.

**Where to Find It**

- Menu Bar: **Rebuild** 
- Menu: **Edit, Rebuild**
- Keyboard Shortcut: **Ctrl+B**

**Tip**

The model is also rebuilt when it is saved.

**Note**

To rebuild *all* features, press **Ctrl+Q**.

---

**16 Double-click on the feature.**

You can double-click on the BasePlate feature either in the FeatureManager design tree or the graphics area. When you do this, the parameters associated with the feature will appear.

Double-click on the **125mm** dimension indicated. The **Modify** dialog box will appear. Enter a new value either by typing it directly or by using the spin box arrows. Enter **150mm** and click **OK**.

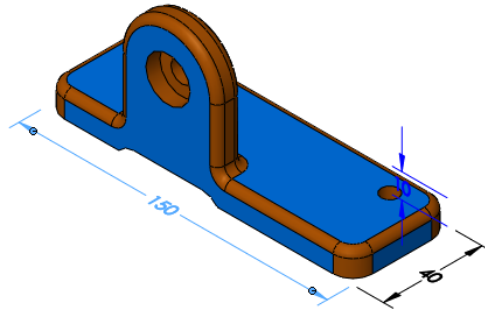

**17 Rebuild the part to see the results.**

Rebuild the part by clicking **Rebuild** . If you use the one on the **Modify** dialog box, the dialog box will stay open so you can make another change. This makes exploring “what if” scenarios easy.

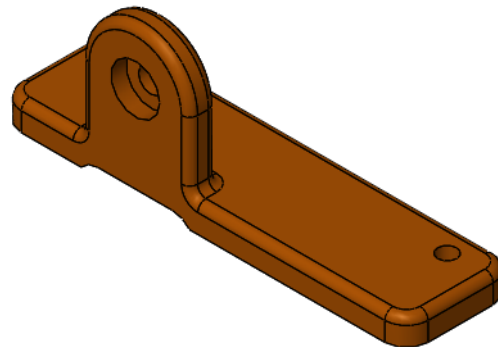

**18 Update the drawing.**

Press **Ctrl+Tab** and click the drawing file to switch back to the drawing sheet. The drawing will update automatically to reflect the changes in the model. Dimensions may move during the rebuilding process and require some clean up.

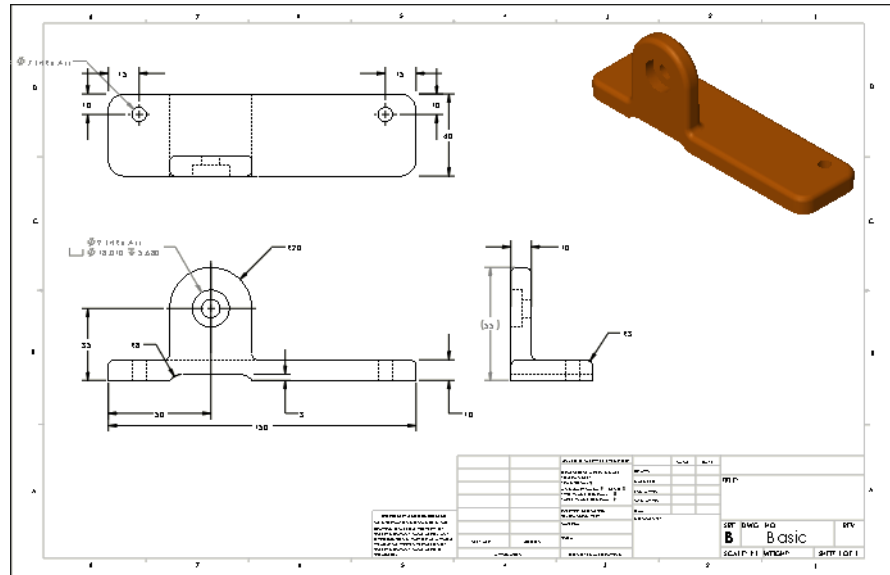
**19 Close the drawing.**

Click **File, Close** to close the drawing. Click **Save All** to save both the drawing and part files.

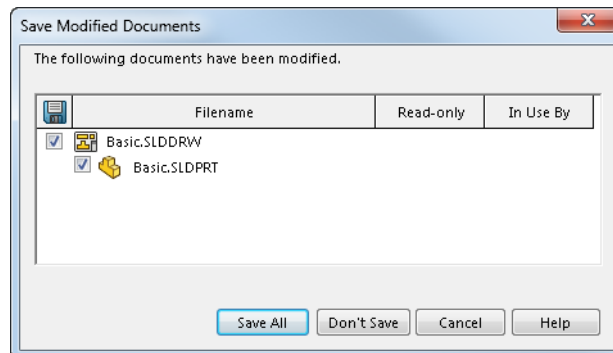
**20 Confirm.**

Click **Yes** to update the drawing views before saving the drawing. Save the drawing file in the same folder as the part.

## Exercise 7: Plate

Create this part using the information and dimensions provided. Sketch and extrude profiles to create the part. This lab reinforces the following skills:

- *Choosing the Best Profile* on page 64
- *Introducing: Corner Rectangle* on page 69
- *Sketching on a Planar Face* on page 71
- *Boss Feature* on page 71
- *Using the Hole Wizard* on page 76

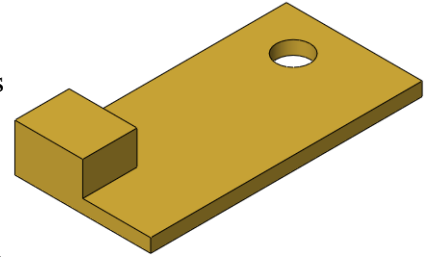

Units: **millimeters**

### Procedure

Create a new mm part and name it Plate. Create the geometry as shown in the following steps.

#### 1 Sketch base feature.

Create a new sketch on the Top plane. Add the geometry and dimensions as shown.

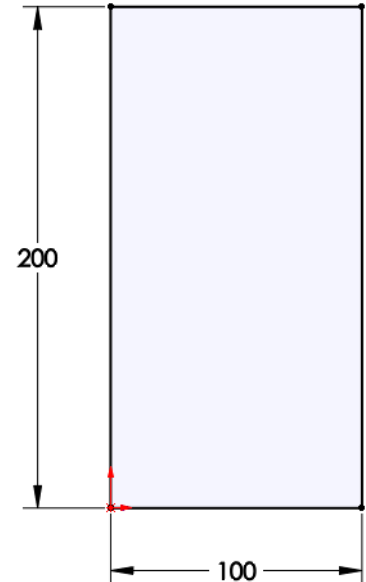

#### 2 Extrude base feature.

Extrude the sketch **10mm** as shown.

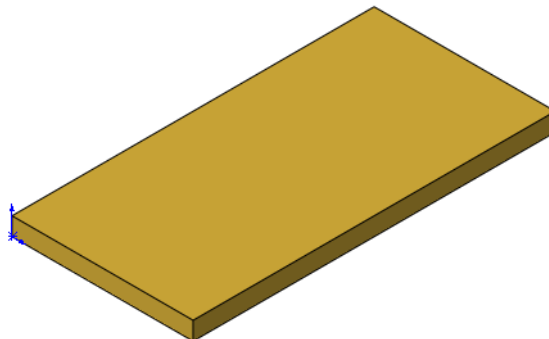

**3 Boss.**

Create a new sketch on the top face of the solid. Add the geometry and dimensions as shown.

Extrude a boss **25mm**.

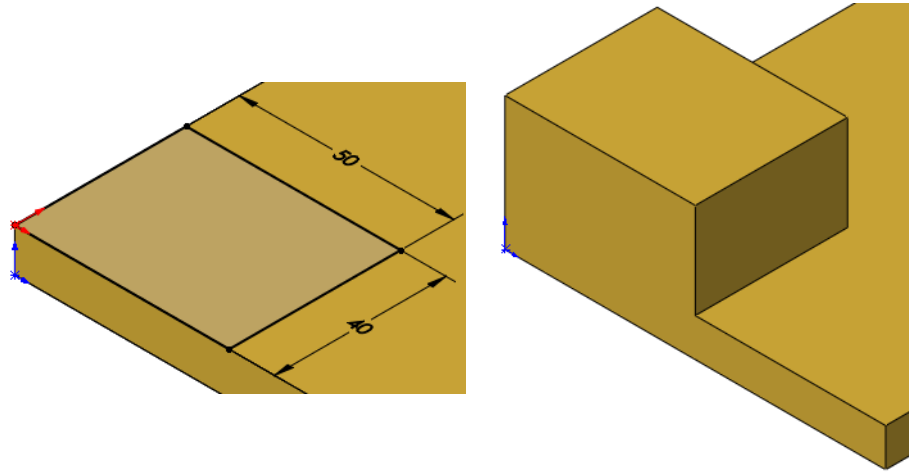
**4 Hole Wizard.**

Click **Hole Wizard**  and click the face shown.

Click the **Type** tab. Set the properties of the hole as follows:

**Type: Hole**

**Standard: Ansi Metric**

**Type: Drill sizes**

**Size: 25mm**

**End Condition: Through All**

Click the **Positions** tab. Place the points as shown.

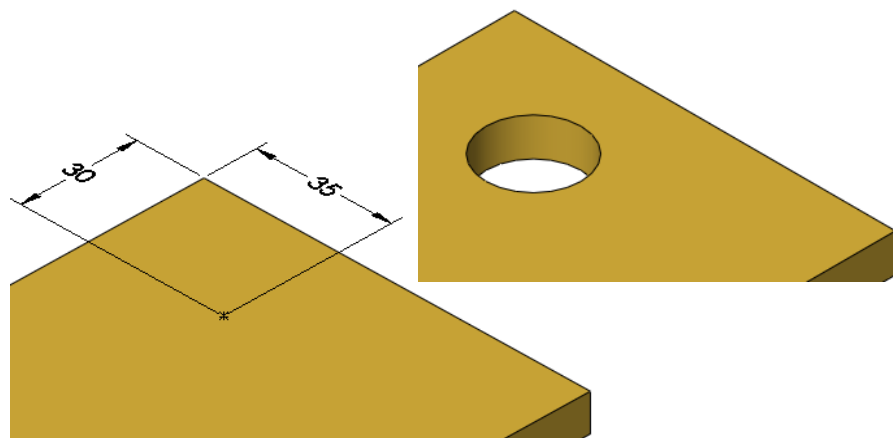
**5 Save and close the part.**

## Exercise 8: Cuts

Use rectangles, tangent arcs and cut features to create the part. This lab reinforces the following skills:

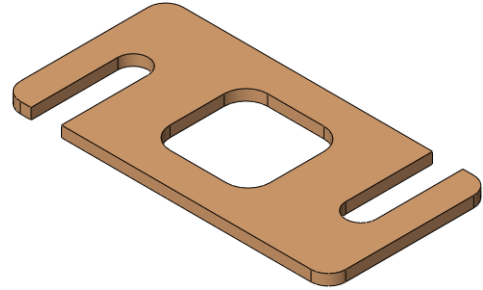

- *Introducing:*  
*Corner Rectangle* on page 69
- *Tangent Arc Intent Zones* on page 72
- *Cut Feature* on page 74
- *Filleting* on page 78

Units: **millimeters**

### Procedure

Create a new mm part and name it Cuts. Create the geometry as shown in the following steps.

#### 1 Sketch base feature.

Create a new sketch on the Top plane. Add the geometry and dimensions as shown.

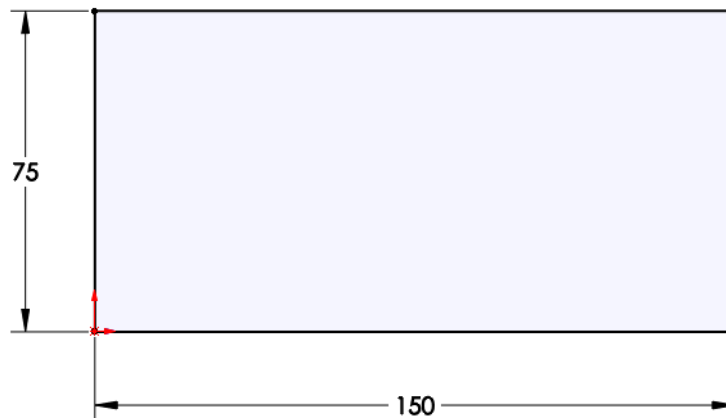

#### 2 Extrude base feature.

Extrude the sketch **5mm** as shown.

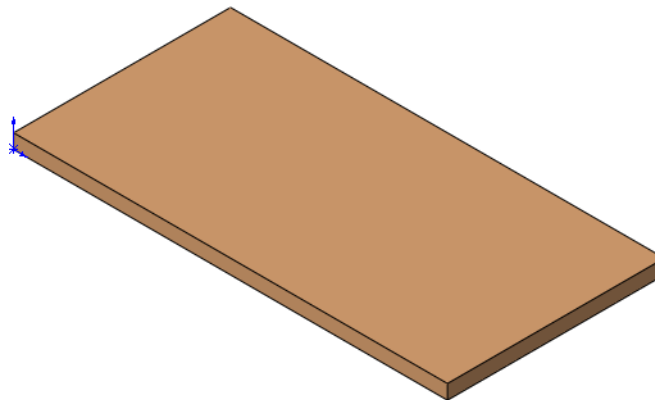

**3 Cut slot.**

Create a new sketch on the top face of the solid. Add the geometry and dimensions as shown.

Extrude a cut using **Through All**.

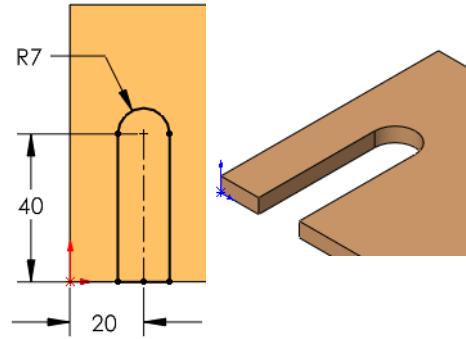

**Tip**

Remember to create a closed profile by sketching the line across the bottom.

**4 Cut another slot.**

Create a new sketch using the same face. Add the geometry and dimensions as shown.

Extrude another cut using **Through All**.

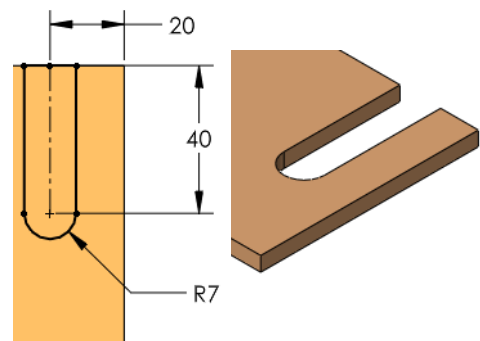

**5 Cut rectangle.**

Create a new sketch using the same face. Add the geometry and dimensions as shown.

Extrude another cut using **Through All**.

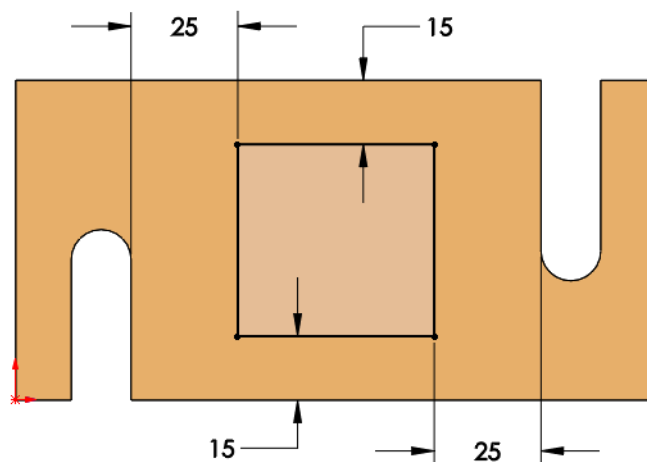

**6 Fillets.**

Add fillets of **R10mm** and **R8mm** to the edges as shown.

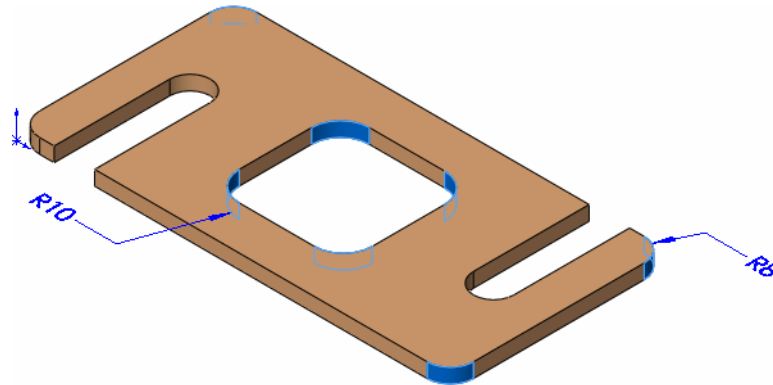

**7 Save and close the part.**

---

## Exercise 9: Basic-Changes

Make changes to the part created in the previous lesson.

This exercise uses the following skills:

- *Changing Parameters* on page 99
- *Rebuilding the Model* on page 99

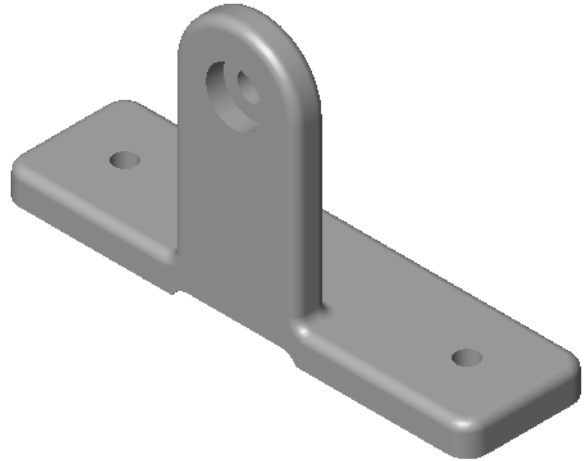

### Procedure

Open an existing part and edit it.

#### 1 Open the part Basic-Changes.

Several changes will be performed on the model to resize it and check the design intent.

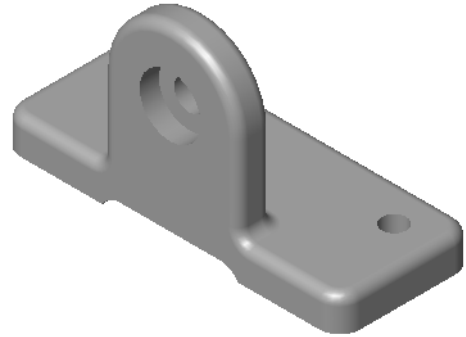

#### 2 Overall dimension.

Double-click the first feature (Base Plate) in the FeatureManager design tree or on the screen to access the dimensions. Change the length dimension to **150mm** (shown bold and underlined below) and rebuild the model.

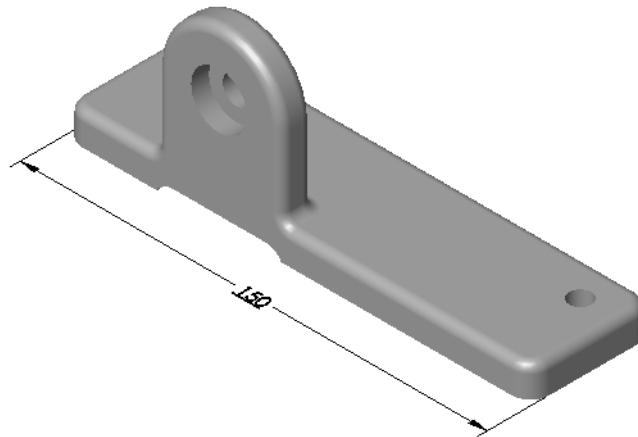

**3 Boss.**

Double-click the Vert boss feature and change the height dimension as shown. Rebuild the part.

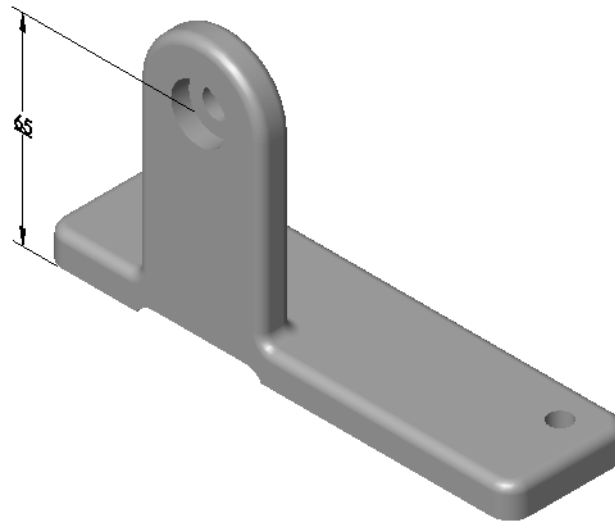

**4 Hole locations.**

Double-click the  $\text{Ø}7.0$  (?) Diameter Hole1 feature and change the position dimensions to **20mm**. Rebuild the model.



**5 Center the Vert Boss.**

Determine the proper value and change the dimension that centers the Vert Boss on the base.

**Tip**

Optionally, you can delete the dimension and add a relations that centers the VertBoss relative to the base.

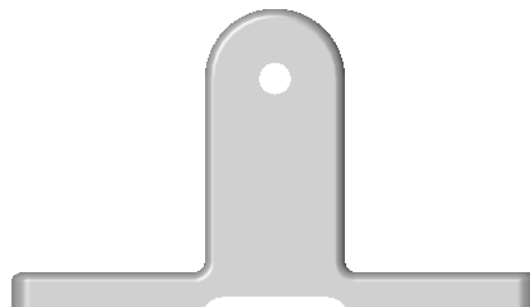

**6 Save and close the part.**

## Exercise 10: Base Bracket

This lab reinforces the following skills:

- *Choosing the Best Profile* on page 64
- *Boss Feature* on page 71
- *Using the Hole Wizard* on page 76
- *Filleting* on page 78

Units: **millimeters**

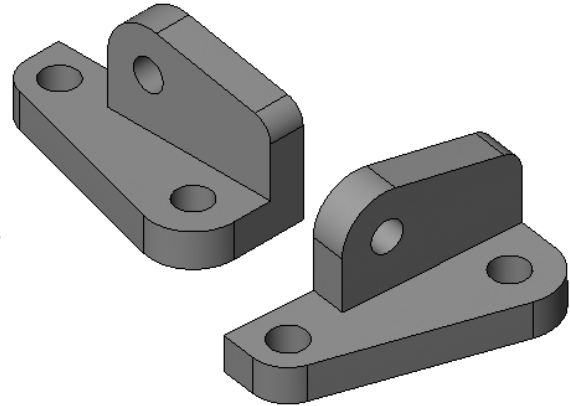

### Procedure

Create a new mm part and name it Base\_Bracket. Create the geometry as shown in the following steps.

#### 1 Sketch base feature.

Create a new sketch on the Top plane. Add the geometry and dimensions as shown.

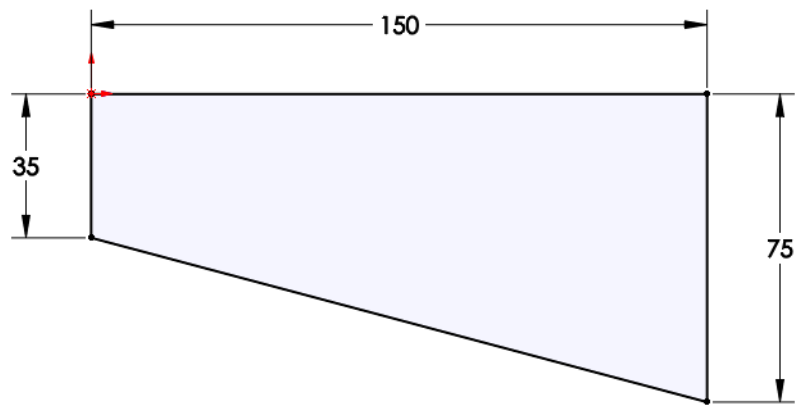

#### 2 Extrude base feature.

Extrude the sketch **20mm** to create the base feature as shown.

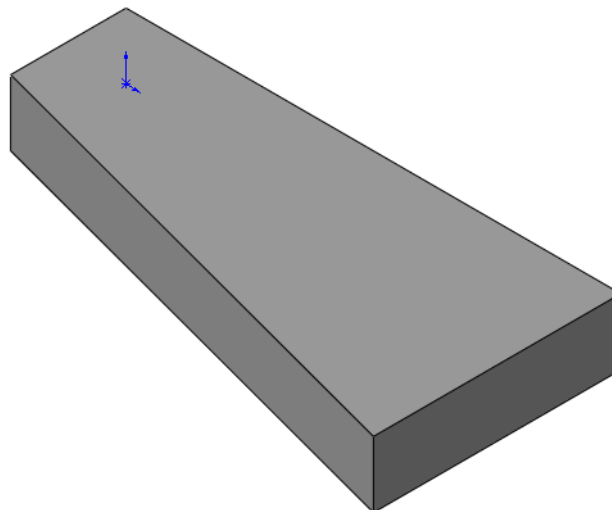

**3 Sketch on rear face.**

Change to the Back view orientation, select the face indicated and create a new sketch. Add the geometry and dimensions as shown.

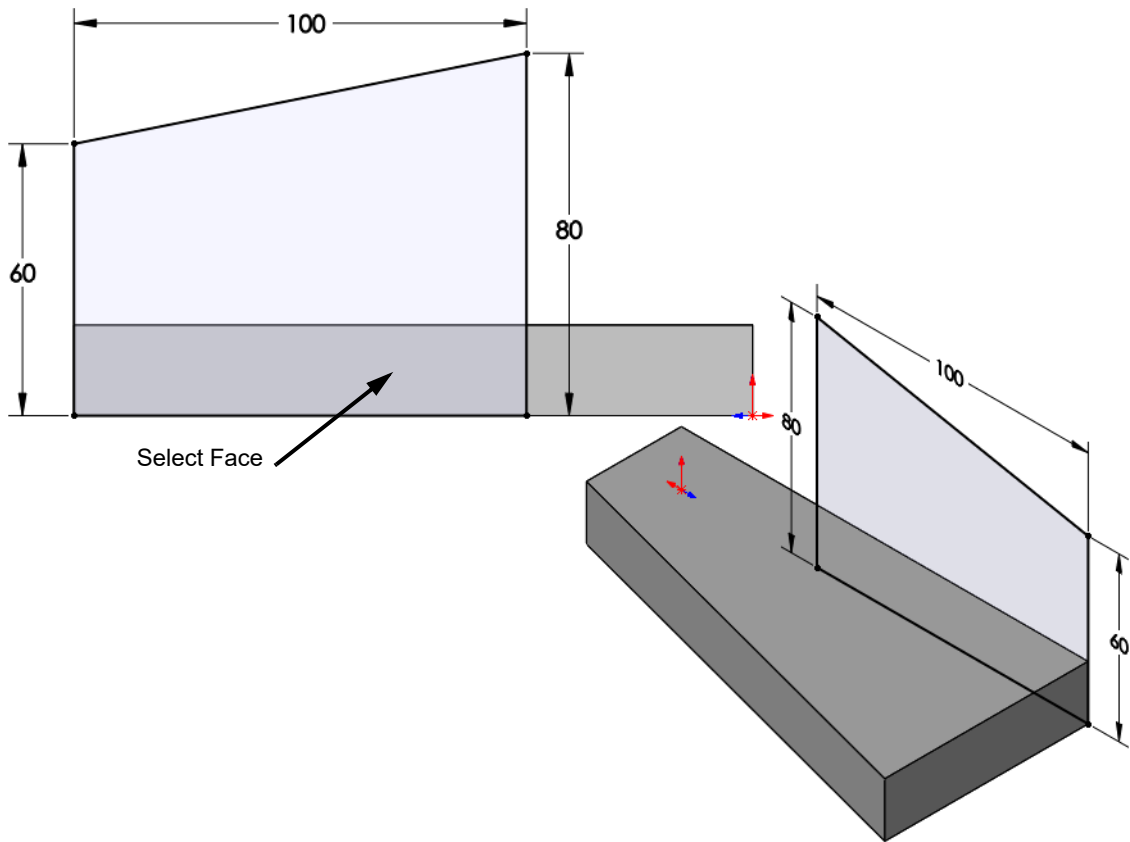

**4 Extrude boss.**

Extrude to the sketch **20mm** as shown.

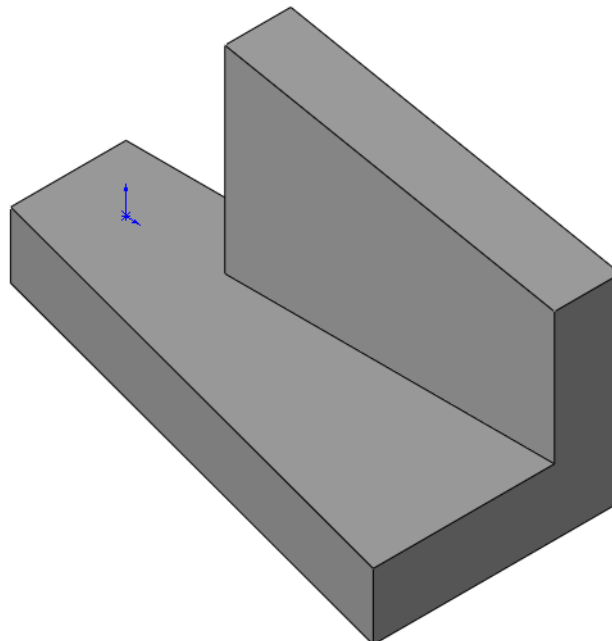

**5 Fillets.**  
Add fillets to the edges as shown.

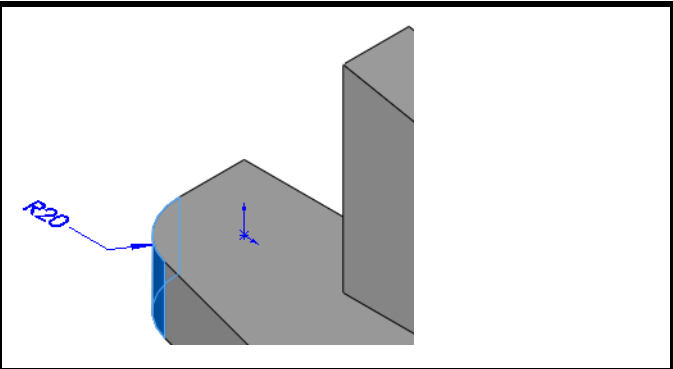
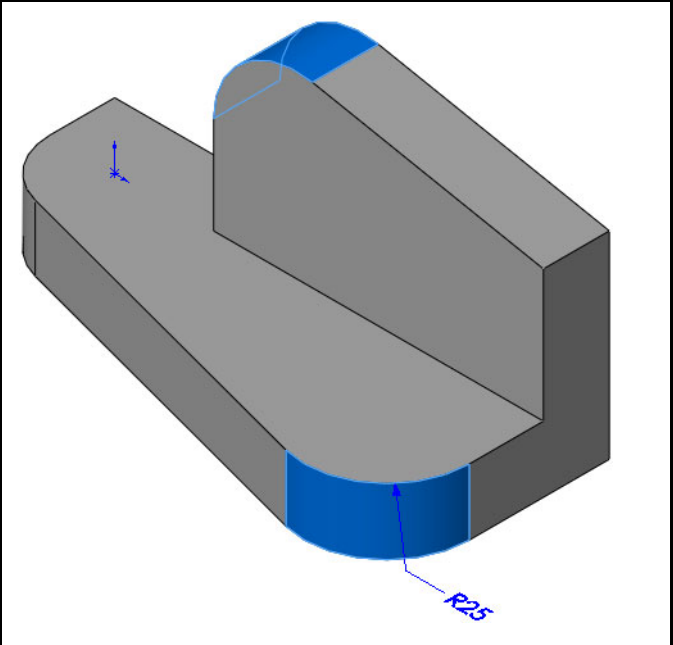
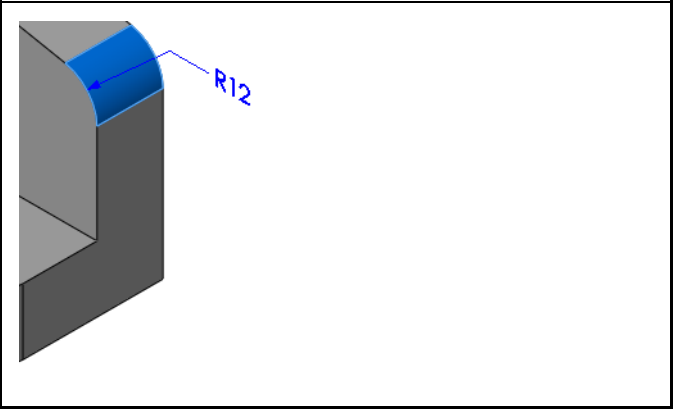
<p><b>R20mm</b></p>	
<p><b>R25mm</b></p>	
<p><b>R12mm</b></p>	

**6 Hole Wizard.**

Click **Hole Wizard**  and click the face shown. Click the Type tab and set the properties of the hole as follows:

**Type: Hole**

**Standard: Ansi Metric**

**Type: Drill sizes**

**Size: 20mm**

**End Condition: Through All**

Click the Positions tab and locate the holes as shown.

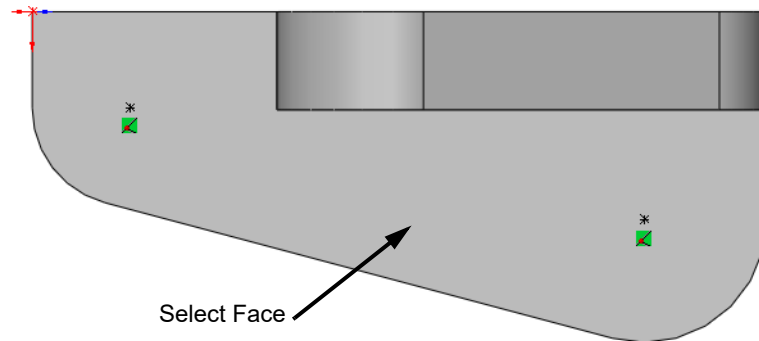

**7 Second hole.**

Repeat the procedure to create an **18mm** hole on a different face as shown.

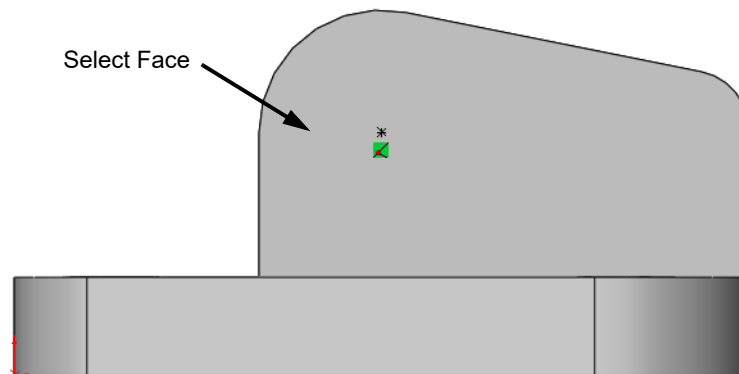

**8 Save and close the part.**

**Exercise 11:  
Part Drawings**

Create this part drawing using the information provided.

This lab reinforces the following skills:

- *New Drawing* on page 88
- *Drawing Views* on page 89
- *Center Marks* on page 93
- *Dimensioning* on page 94

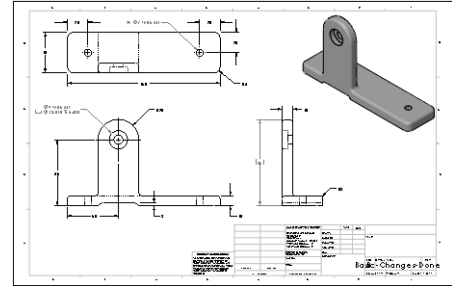
**Procedure**

Create a new drawing and add the views and dimensions shown in the following steps.

**1 Open part.**

Open the part Basic-Changes-Done.

**2 New drawing.**

Use the **Make Drawing from Part** command and the B\_Size\_ANSI\_MM template to create the drawing views as shown.

**3 Dimensions.**

Add the annotations and dimensions as shown.

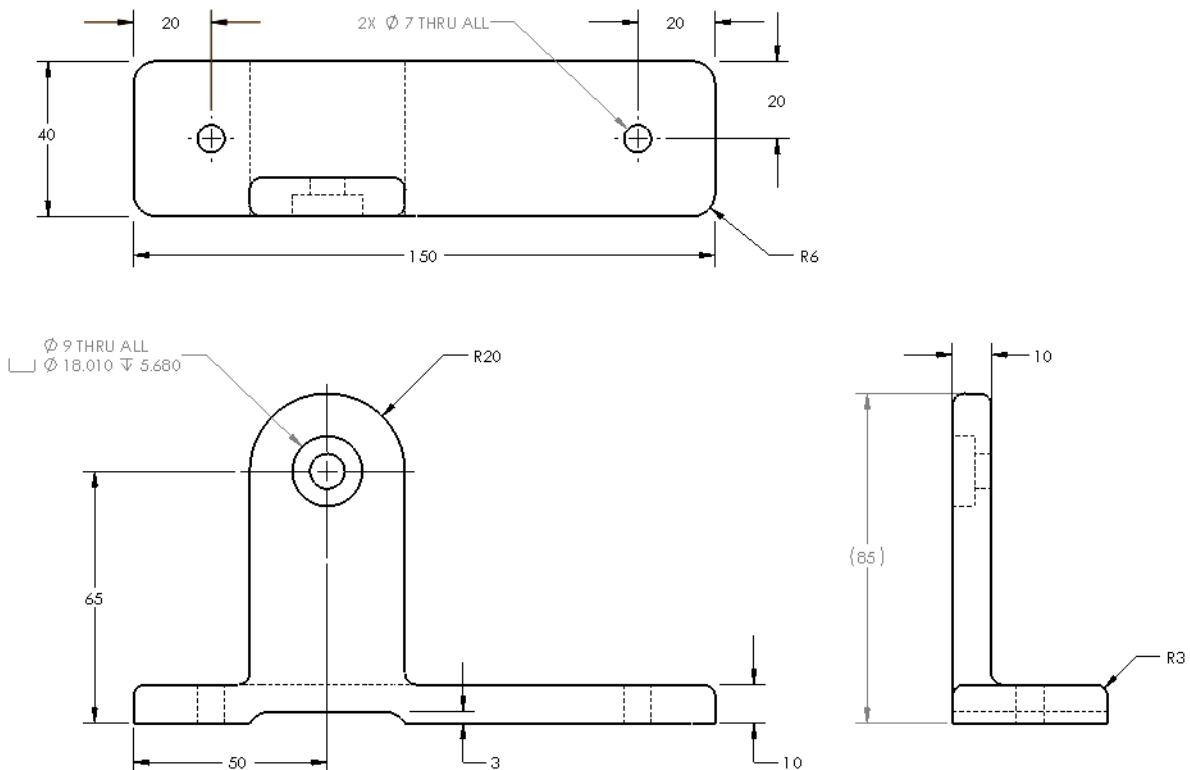
**4 Save and close all files.**



# Lesson 4

## Patterning

Upon successful completion of this lesson, you will be able to:

- Create a linear pattern.
- Add a circular pattern.
- Use geometry patterns properly.
- Create and use the reference geometry types axes and planes.
- Create a mirror pattern.
- Use the pattern seed only option with a linear pattern.
- Add a sketch driven pattern.
- Automate the process of fully defining a sketch.

## Why Use Patterns?

Patterns are the best method for creating multiple instances of one or more features when the design intent is for the features to always remain the same. Use of patterns is preferable to other methods for several reasons.

- **Reuse of geometry**

The original or **Seed** feature is created only once. **Pattern Instances** of the seed are created and placed, with references back to the seed.

- **Changes**

Due to the seed/instance relationship, changes to the seed are automatically passed on to the instances.

- **Use of Assembly Component Patterns**

Patterns created at the part level are reusable at the assembly level as **Pattern Driven Patterns**. The pattern can be used to place component parts or subassemblies.

- **Smart Fasteners**

One last advantage of patterns is to support the use of Smart Fasteners. Smart Fasteners are used to automatically add fasteners to the assembly. These are specific to holes.

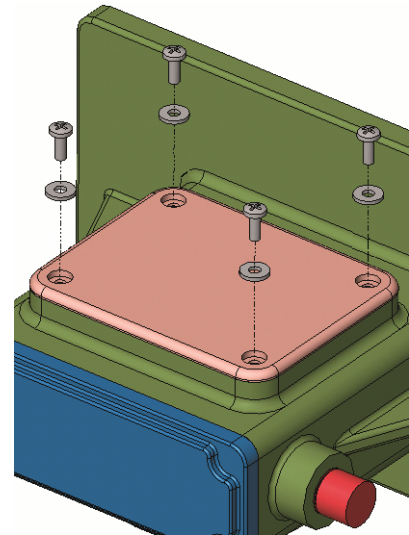

## Pattern Terminology

To use patterns, you should understand the terms seed and pattern instance.

- **Seed**

The seed is the geometry to be patterned. It can be one or more features, bodies or faces.

- **Pattern Instance**











The **Pattern Instance** (or just **Instance**) is the “copy” of the seed created by the pattern. It is in fact much more than a copy because it is derived from the seed and changes with the seed.

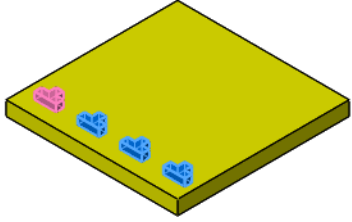

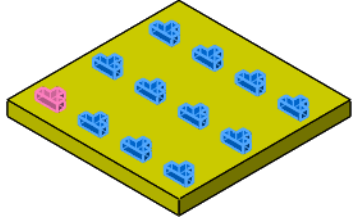

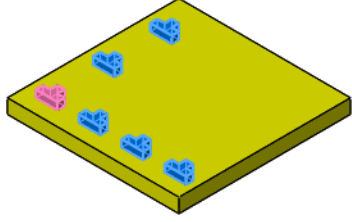

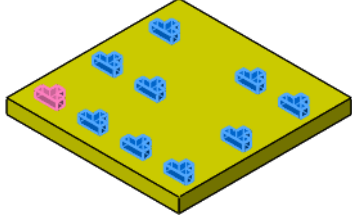

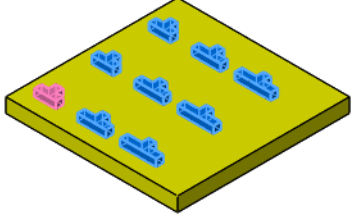

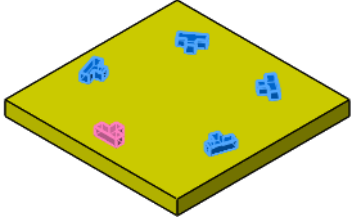
**Types of Patterns**

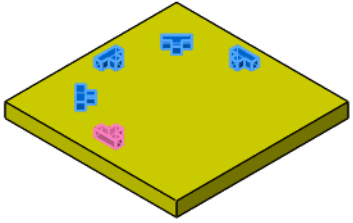

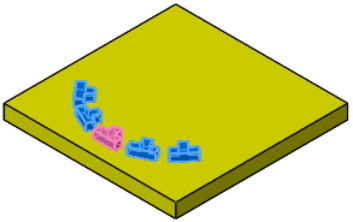

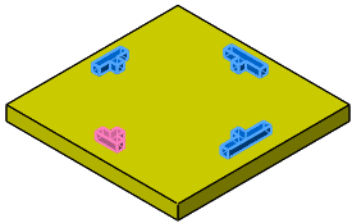

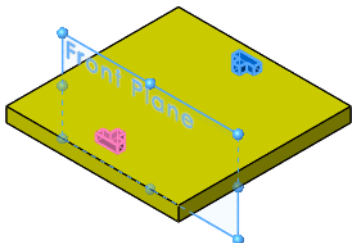

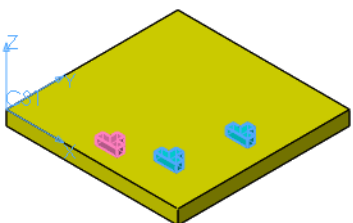

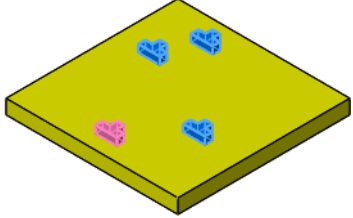
There are many types of patterns available in SOLIDWORKS and the following table is intended to highlight the typical uses for each type.

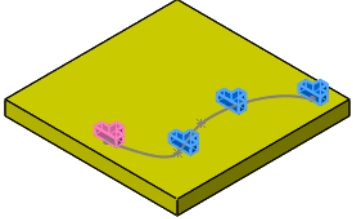
**Note**

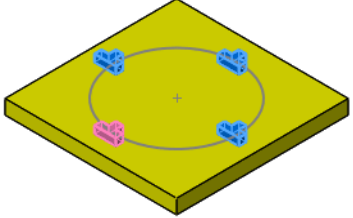
Not all of the pattern types in the table are shown as case studies.

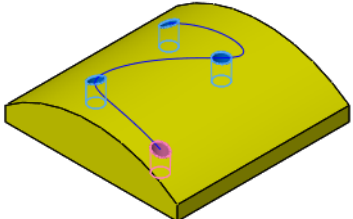

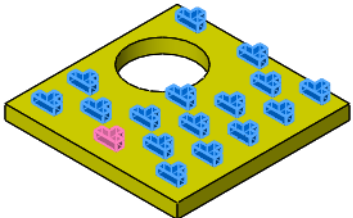

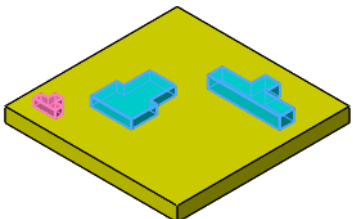



Pattern Type:	Typical usage:	Key: Seed =  Pattern Instance = 
<b>Linear</b> ..... 	One-directional array with equal spacing.	
<b>Linear</b> ..... 	Two-directional array with equal spacing.	
<b>Linear</b> ..... 	Two-directional array; pattern seed only.	
<b>Linear</b> ..... 	One- or two-directional array. Selected instances removed.	
<b>Linear</b> ..... 	One- or two-directional array. Selected dimensions varied.	

<p><b>Circular</b> . . . . . </p>	<p>Circular array with equal spacing about a center.</p>	
<p><b>Circular</b> . . . . . </p>	<p>Circular array with even spacing about a center. Selected instances removed or angle less than 360°.</p>	
<p><b>Circular</b> . . . . . </p>	<p>Circular array with even spacing about a center and symmetric spacing.</p>	
<p><b>Circular</b> . . . . . </p>	<p>Circular array with selected dimensions varied.</p>	
<p><b>Mirror</b> . . . . . </p>	<p>Mirrored orientation about a selected plane.</p>	
<p><b>Table Driven</b> . . . </p>	<p>Arrangement based on a table of XY locations from a coordinate system.</p>	



<p><b>Sketch Driven . . .</b> </p>	<p>Arrangement based on the positions of points in a sketch.</p>	
<p><b>Curve Driven . . .</b> </p>	<p>Arrangement based on the geometry of a curve.</p>	
<p><b>Curve Driven . . .</b> </p>	<p>Arrangement of full or partial circular path.</p>	
<p><b>Curve Driven . . .</b> </p>	<p>Arrangement based on the geometry of a projected curve.</p>	
<p><b>Fill . . . . .</b> </p>	<p>Arrangement of instances to pattern based on a face.  Fill can also use default shapes: circles, squares, diamonds, or polygons.</p>	
<p><b>Variable . . . . .</b> </p>	<p>Arrangement based on selected dimensions in a pattern table varied along a planar or curved surface.</p>	

## Pattern Options

Pattern features share several options. They are unique to this class of feature and will be discussed in detail later in this lesson.

Pattern Feature	Select Feature, Bodies or Faces	Propagate Visual Properties	Pattern Seed Only	Skip Instances	Geometry Pattern	Vary Sketch	Instances to Vary
Linear 	✓	✓	✓	✓	✓	✓	✓
Circular 	✓	✓		✓	✓		✓
Mirror 	✓	✓			✓		
Table Driven 	✓	✓			✓		
Sketch Driven 	✓	✓			✓		
Curve Driven 	✓	✓	✓	✓	✓	✓	
Fill 	✓	✓		✓	✓	✓	
Variable 	Features only	✓					All instances vary

### Note

The sketch options **Linear Sketch Pattern**  and **Circular Sketch Pattern**  can be used within a sketch to create copies of sketch geometry. They *do not* create pattern features.

## Linear Pattern

The **Linear Pattern** tool creates copies, or instances, in one- or two-dimensional arrays. Each array is controlled by a direction, a distance and a number of copies or instances.

The direction can be defined by an edge, axis, temporary axis, linear dimension, planar face/surface, conical face/surface, circular edge, sketch circle/arc, or reference plane.

The instances are dependent on the originals. Changes to the originals are passed on to the instanced features. This example uses the **Spacing and Instances** option. For the **Up to reference** option, see page 139.

### Note

The number of instances includes the original or seed instance.

### Where to Find It

- CommandManager: **Features > Linear Pattern** 
- Menu: **Insert, Pattern/Mirror, Linear Pattern**

#### 1 Open the part named **Linear Pattern**.

The part contains the seed feature that will be used in the pattern.

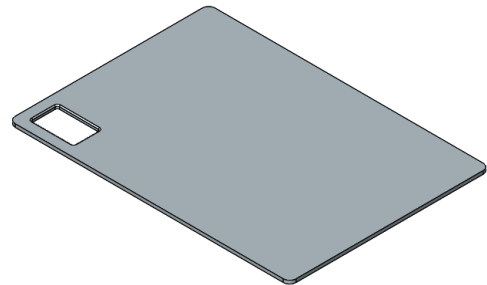

#### 2 Direction 1.

Click **Linear Pattern** . Select the linear edge of the part and click **Reverse**

**Direction** , if necessary, to set the direction shown.

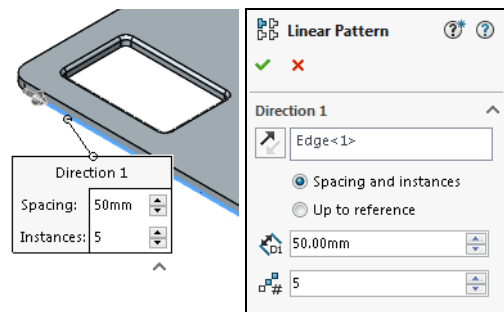

Click **Spacing and instances**, set the **Spacing** to **50mm** and **Number of Instances** to **5**.

### Note

The callout is attached to the geometry used to define the pattern direction or axis. It contains the key settings for **Spacing** and **Instances** and is editable. Click the value field to change to change the value.

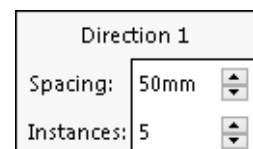

## Flyout FeatureManager Design Tree

The flyout FeatureManager design tree enables you to view both the FeatureManager design tree and the PropertyManager at the same time. This enables you to select features from the FeatureManager design tree when it would otherwise be obscured by the PropertyManager. It is also transparent, overlaying the part graphics.

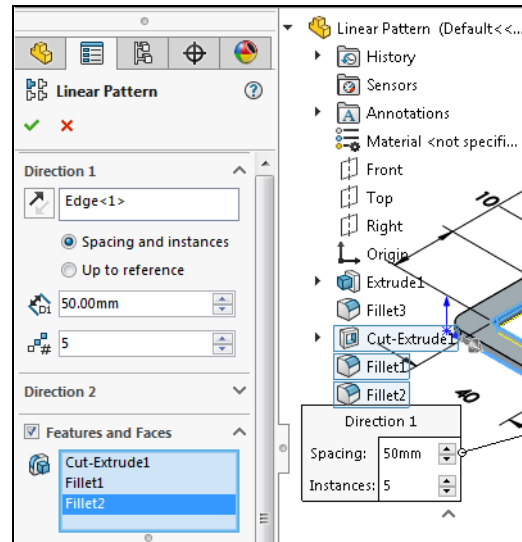

The flyout FeatureManager design tree is activated automatically with the PropertyManager. It may appear collapsed and can be expanded by clicking on the arrow icon preceding the top level feature.

### 3 Select features.

Click in **Features and Faces** and **Features to Pattern**. Select the features Cut-Extrude1, Fillet1 and Fillet2 from the flyout FeatureManager tree.

### 4 Direction 2.

Expand the **Direction 2** group box and click a second linear edge as shown.

Click **Spacing and instances**, set the **Spacing** to **35mm** and **Instances** to **5**.

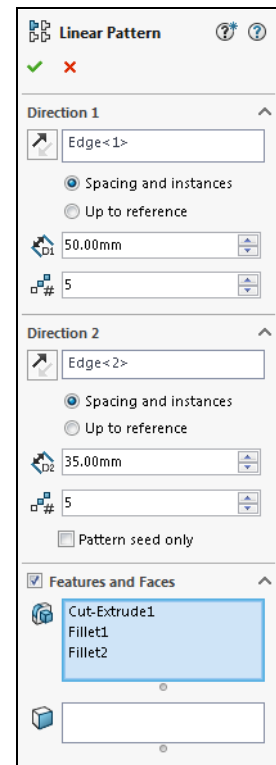
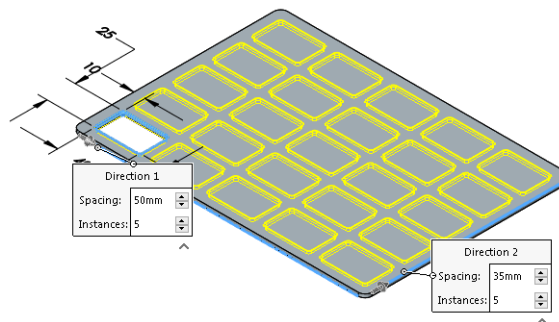

**Skipping Instances**

Specific instances that are generated by the pattern can be skipped by selecting a marker at the centroid of the instance shown in the pattern preview. Each instance is listed in array format **(2,3)** for identification.

**Note**

The seed feature cannot be skipped.

**5 Instances to Skip.**

Expand the **Instances to Skip** group box and drag-select the center instance markers as shown. The tooltip shows an array location that is added to the list when selected. Click **OK** to add the pattern feature LPattern1.

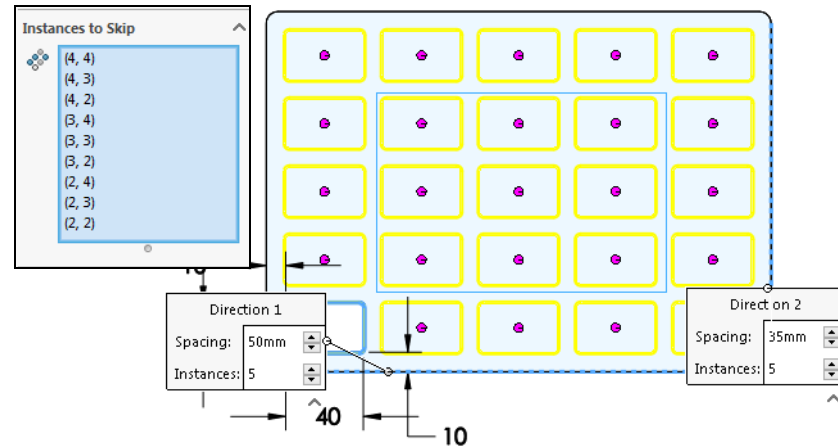

**Note**

The input box can be expanded by dragging the bottom edge.

**6 Seed and instances.**

Click on the pattern in the FeatureManager design tree to highlight the seed and instances in different colors. The tooltip for the pattern feature includes information about the settings that are used.

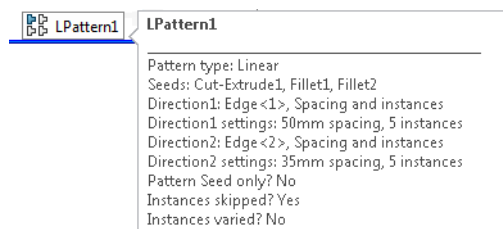
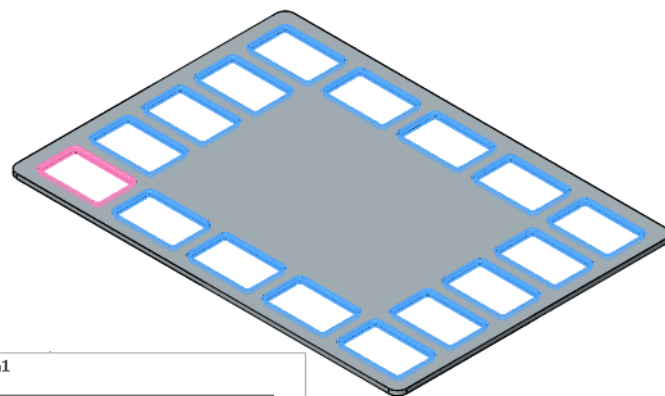

## Geometry Patterns

The **Geometry Pattern** option is used to minimize rebuild time by using the **Seed** geometry for all **Instances** in the pattern. It should only be used when the geometry of the seed and the instances are of identical or similar shape.

### ■ Without Geometry Pattern

If the **Geometry Pattern** option is *cleared*, the end condition of the seed is used in the instances. In this example, the **Offset From Surface** end condition of the blue seed feature is applied in the orange instances, forcing them to use the same end condition.

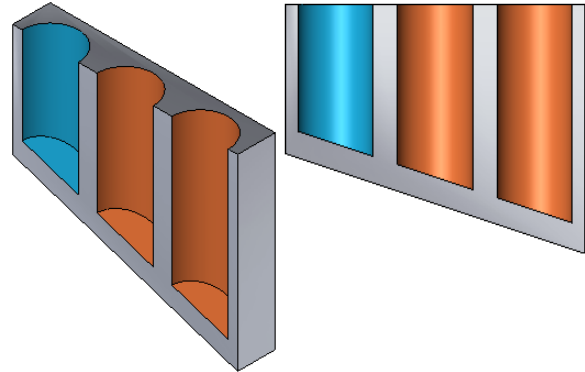

### ■ With Geometry Pattern

If the **Geometry Pattern** option is *checked*, the geometry of the seed is used. The geometry is copied along the pattern, ignoring the end condition.

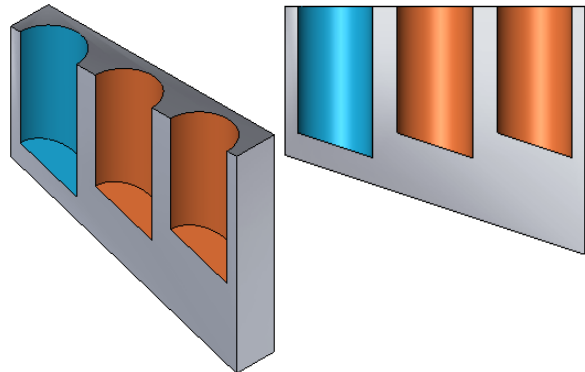

## 7 Geometry Pattern.

Right-click the LPattern.1 feature and click **Edit**

**Feature** . Check the **Geometry pattern** option and click **OK**. Because the plate is constant thickness, the resulting geometry will look the same.

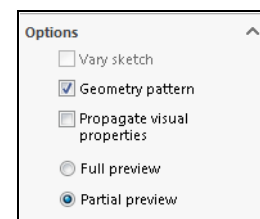

**Performance Evaluation**

**Performance Evaluation** is a tool that displays the amount of time it takes to rebuild each feature in a part. Use this tool to identify the features that take a long time to rebuild. Once they are identified, you can possibly edit them to increase efficiency, or suppress them if they are not critical to the editing process.

**Introducing: Performance Evaluation**

The **Performance Evaluation** dialog box displays a list of all features and their rebuild times in descending order.

- **Feature Order**

Lists each item in the FeatureManager design tree: features, sketches, and derived planes. Use the shortcut menu to **Edit Feature**, **Suppress** features, and so on.

- **Time%**

Displays the percentage of the total part rebuild time to regenerate each item.

- **Time**

Displays the amount of time in seconds that each item takes to rebuild.

**Where to Find It**

- CommandManager: **Evaluate > Performance Evaluation** 
- Menu: **Tools, Evaluate, Performance Evaluation**

**8 Performance Evaluation.**

Click **Performance**

**Evaluation** .

The features are listed in descending order according to the amount of time required to regenerate them.

Click **Close**.

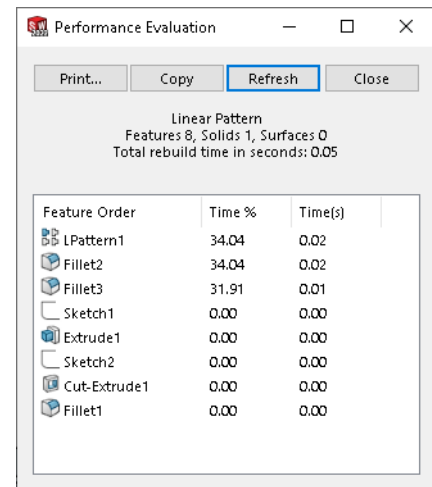
**9 Geometry Pattern off.**

Right-click the LPattern1 feature and click **Edit Feature** .

*Clear* the **Geometry pattern** option and click **OK**.

### 10 Repeat.

Click **Performance Evaluation**  again.

The LPattern1 feature uses a larger portion of the rebuild time when the geometry pattern is toggled off.

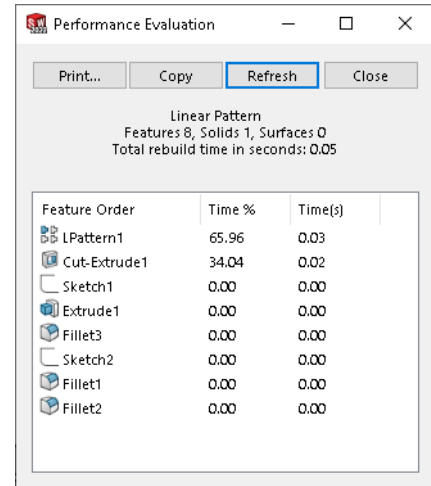

### 11 Save and close the part.

#### Interpreting the Data

The first thing to keep in mind is that the total rebuild time for this part is much less than one second, so a change to any one feature is not likely to make a significant difference.

The second thing is the number of significant digits and rounding error. For example, Feature1 may appear to take twice as long to rebuild as Feature2, 0.02 seconds versus 0.01 seconds. Does this indicate a problem with Feature1? Not necessarily. It is quite possible that Feature1 takes 0.0151 seconds while Feature2 takes 0.0149 seconds, a difference of only 0.0002 seconds.

Use **Performance Evaluation** to identify features that significantly impact rebuild time. Then either:

- Suppress or delete features to improve performance. Optionally, you can do this directly from the **Performance Evaluation** dialog box.
- Analyze and modify features to improve performance.

#### What Affects Rebuild Time?

Features can be analyzed to determine why they behave as they do. Depending on the feature type and how it is used, the reasons will vary.

For sketched features, look for external relations and end conditions that reference other features. Keep these relations attached to the earliest feature possible. Do the same for sketch planes.

#### Tip

In general, the more parents that a feature has, the slower it will rebuild.

For features applied to edges or faces, check the feature's options and the position of the feature in the FeatureManager design tree.

## Circular Patterns

### Introducing: Circular Pattern

### Where to Find It

The **Circular Pattern** tool creates copies, or instances, in a circular pattern controlled by a center of rotation, an angle and the number of copies. Changes to the originals are passed on to the instanced features.

**Circular Pattern** creates multiple instances of one or more features spaced around an axis. The axis can be derived from a circular face, circular or linear edge, axis, temporary axis or angular dimension.

- CommandManager: **Features > Linear Pattern**  > **Circular Pattern** 
- Menu: **Insert, Pattern/Mirror, Circular Pattern**

### 1 Open the part named **Circular\_Pattern**.

### 2 Pattern Axis.

Click **Circular Pattern** .

Click in **Pattern Axis** and click the cylindrical face of the model as shown.

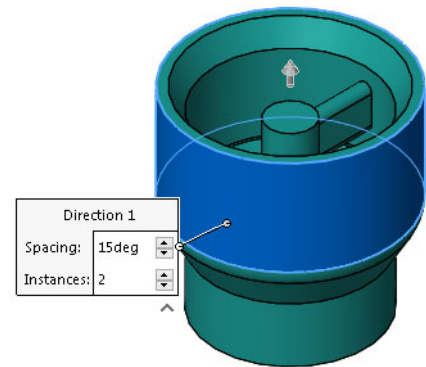

### 3 Settings.

Click in **Features and Faces** and click the three features shown for **Features to Pattern**.

Click **Equal Spacing**, **4** instances and click **Geometry pattern**.

Check that the **Angle** is set to **360°** and click **OK**.

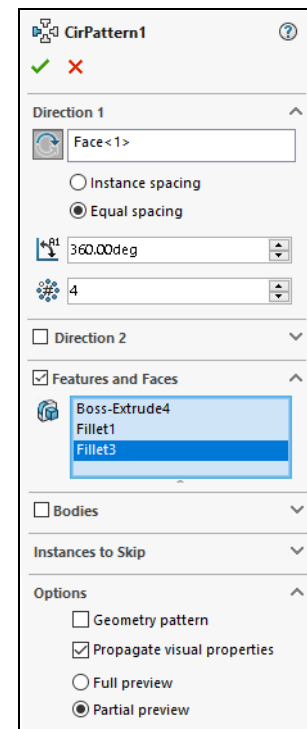
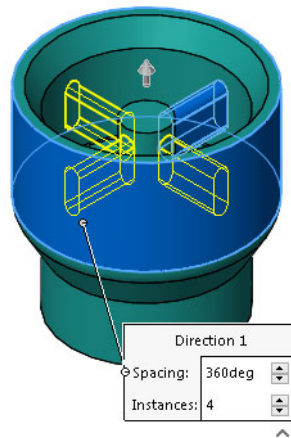

**Note**

The **Reverse Direction**

and **Symmetric** options are meaningful only when an angle other than 360° is used.

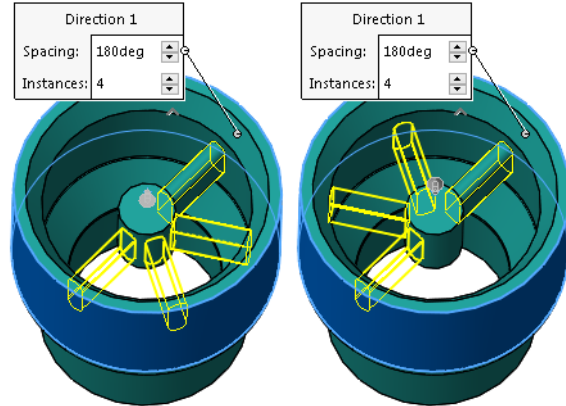

4 Save and close the part.

**Reference Geometry**

There are three types of **Reference Geometry** that are useful in creating patterns: **Temporary Axes, Axes** and **Planes**. For more information on planes, see *Planes* on page 130.

**Axes**

**Axes** are features that must be created using one of several methods. The advantages to creating an axis is that it can be renamed, selected by name from the FeatureManager design tree, and resized.

**Temporary Axes**

Every cylindrical and conical face has an axis associated with it. To view a specific temporary axis, float the cursor over a cylindrical or conical face of the part. To view all of the temporary axes in the part, click **View, Temporary Axes**.

One axis is displayed through each circular face in the model.

Here are some examples of creating feature axes:

<p><b>Temporary Axes</b> can be made permanent using the <b>One Line/Edge/Axis</b> option.</p>		<p>Select two planes or planar faces and the option <b>Two Planes</b>.</p>	
------------------------------------------------------------------------------------------------	--	----------------------------------------------------------------------------	--

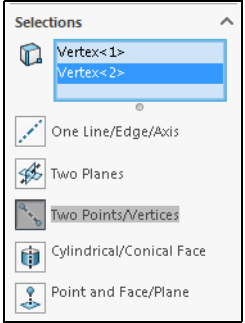
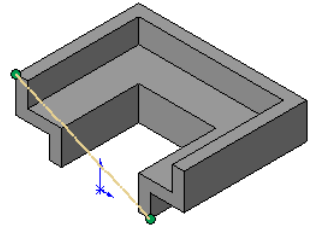
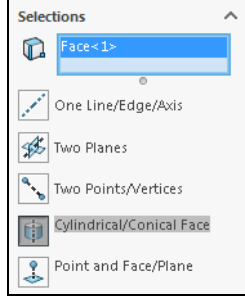
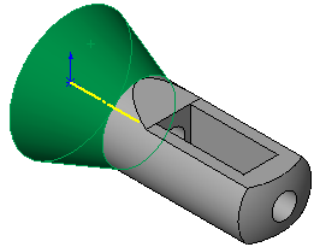
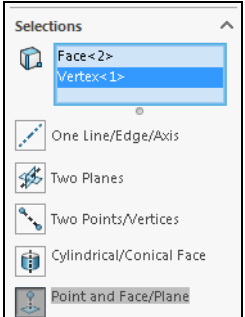
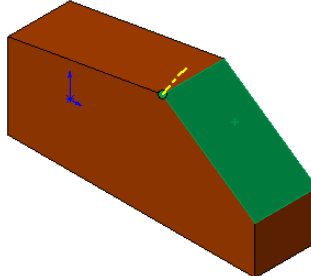
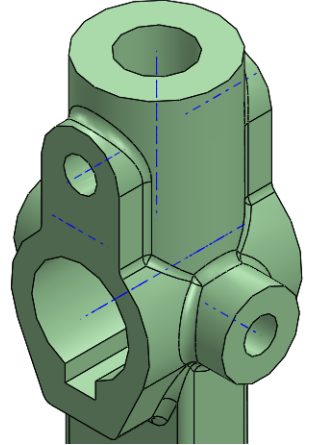

<p>Select <b>Two Points/Vertices</b> to define an axis through them.</p> 		<p>Select a <b>Cylindrical/Conical Face</b> to define an axis through the rotational center.</p> 	
<p>Select a plane or planar face and a point or vertex to define an axis normal to the plane through the point.</p> 		<p>View and use the temporary axes of any part.</p>	

**Where to Find It**

- CommandManager: **Features > Reference Geometry**  > **Axis** 

- Menu: **Insert, Reference Geometry, Axis**

**Where to Find It**

- Float over a cylindrical or conical face
- Heads-up View Toolbar: **Hide/Show Items**  > **View Temporary Axes** 
- Menu: **View, Temporary Axes**

**1 Open the part named `Circular_Pattern with Axis`.****2 Create axis.**

Click **Axis**  and select the Front and Right planes as shown. The **Two Planes** option is selected automatically. Click **OK** to add Axis1.

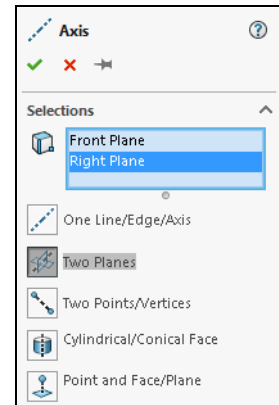
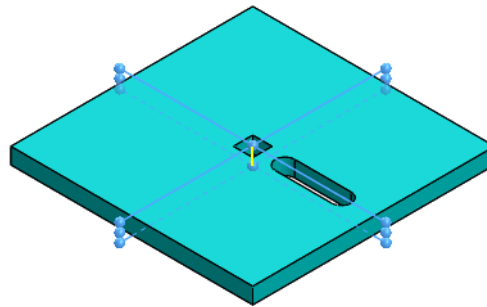
**3 Circular pattern.**

Click **Circular Pattern** , click in **Pattern Axis** and click the axis Axis1. Click in **Features and Faces** and click the feature Cut-Extrude1. Click **Equal Spacing**, **4 instances** and **OK**.

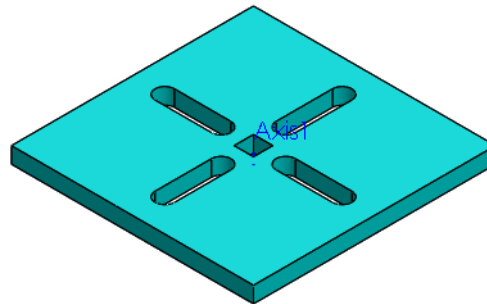
**4 Save and close the part.****Planes**

The **Plane Wizard** can be used to create a variety of planes using different geometry. Planes, faces, edges, vertices, surfaces and sketch geometry can all be used to apply constraints through **First**, **Second** and optionally **Third References**. The **Fully defined** state is listed when it is reached.

**Note**

To view and select hidden planes in a part or an assembly component, press Q. This can be particularly useful when creating mates in an assembly. See *Things to which you can mate* on page 222 for more information.

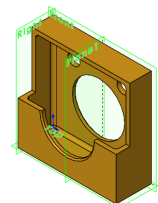

**Tip**

If the selections cannot be combined to form a valid plane, a message appears in the dialog.

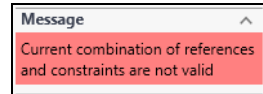

**Shortcut**

Press **Ctrl** and drag an existing plane to start the **Offset Distance** plane as shown below.

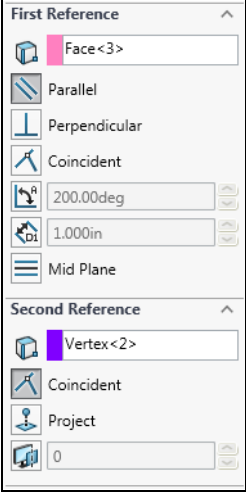
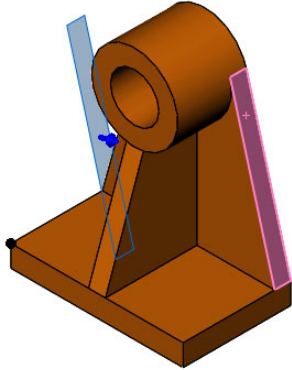
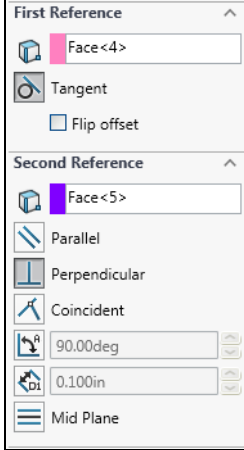
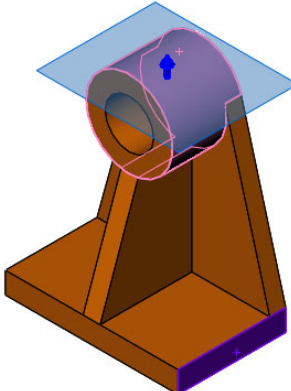
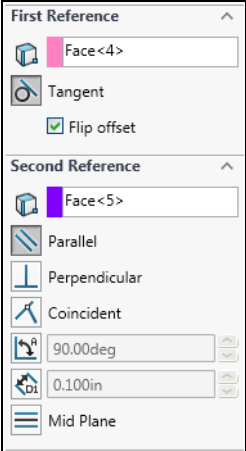
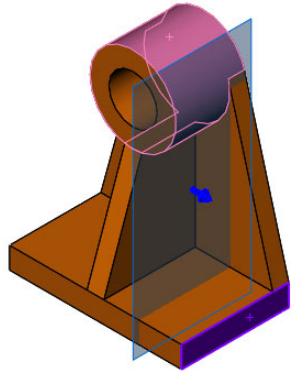
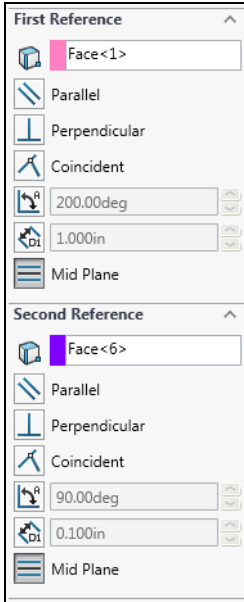
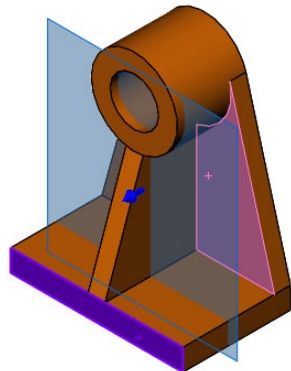

Here are some examples of creating planes:

<p><b>Offset Distance</b> Select a planar face or plane and a distance.</p>	<p>Optionally create a series of parallel planes the same distance apart.</p>	<p><b>Angle</b> Select a planar face or plane and an edge or axis.</p>	<p>Optionally create a series of angled planes the same distance apart.</p>
<p><b>Coincident</b> Select three vertices.</p>		<p><b>Coincident</b> Select a line and a single vertex.</p>	

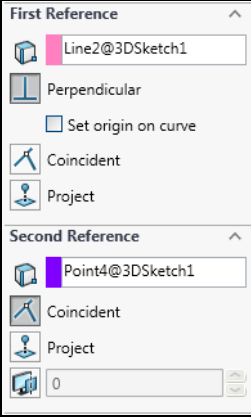
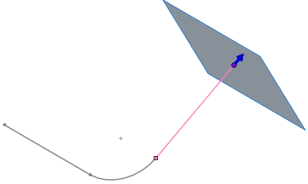
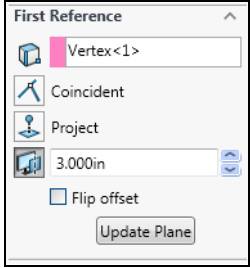
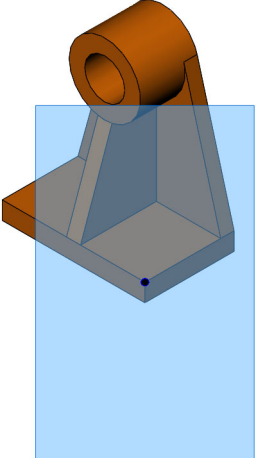
<p><b>Parallel</b> Select a face and a vertex.</p> 		<p><b>Tangent and Perpendicular</b> Select a cylindrical face and a planar face or plane with <b>Perpendicular</b>.</p> 	
<p><b>Tangent and Parallel</b> Select a cylindrical face and a planar face or plane with <b>Parallel</b>.</p> 		<p><b>Mid Plane</b> Select two planar faces with <b>Mid Plane</b>.</p> 	

<p><b>Perpendicular at a Point</b> Select a sketched line and an endpoint.</p> 	 <p>As a shortcut to Perpendicular at a Point, select an edge/line and click <b>Insert, Sketch</b>. The plane is created and a sketch opened on it.</p>	<p><b>Create a plane parallel to the screen</b> Select a vertex and optionally an offset.</p>  <p>Optionally, right-click geometry and click <b>Create Plane Parallel to Screen</b>.</p>	
----------------------------------------------------------------------------------------------------------------------------------------------------------------------	------------------------------------------------------------------------------------------------------------------------------------------------------------------------------------------------------------------------------------------	--------------------------------------------------------------------------------------------------------------------------------------------------------------------------------------------------------------------------------------------------------------------------------	-------------------------------------------------------------------------------------

**Note** The toggle **View, Hide/Show All Types** can be used to hide or show all planes, axes and sketches at once.

- Where to Find It**
- CommandManager: **Features > Reference Geometry**  > **Plane** 
  - Menu: **Insert, Reference Geometry, Plane**

- 1 Open the part named **Mirror Pattern**.**  
A cut feature in this model will be mirrored across one and two planes.
- 2 First reference.**  
Click **Plane**  and select the outer face as shown.

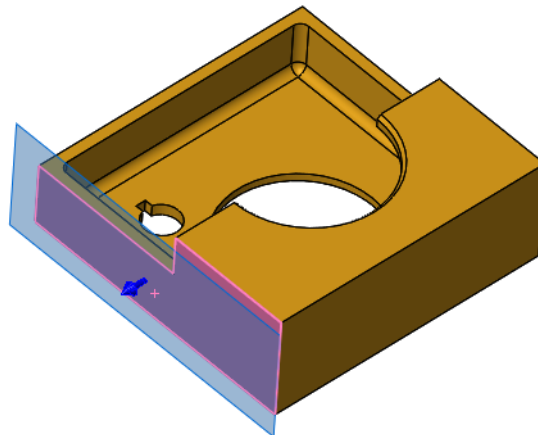
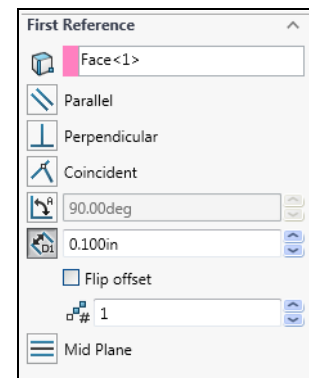
**3 Second reference.**

Select the second outer face as shown. A preview of the plane appears centered between the reference selections. The **Mid Plane** option is selected automatically. Click **OK**.

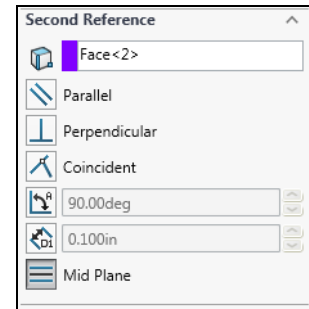
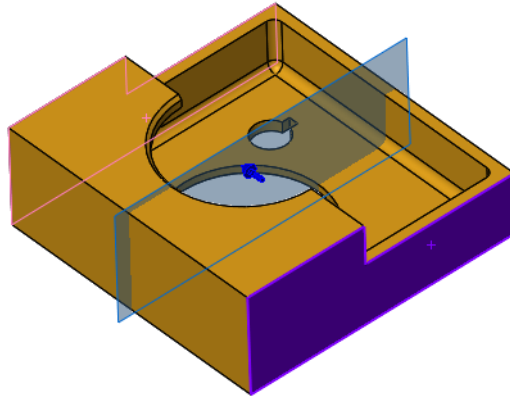

Name the plane `vert_ctr`.

**4 Second plane.**

Click **Plane** again and select the top face as the **First Reference**. Set it to **Parallel**.

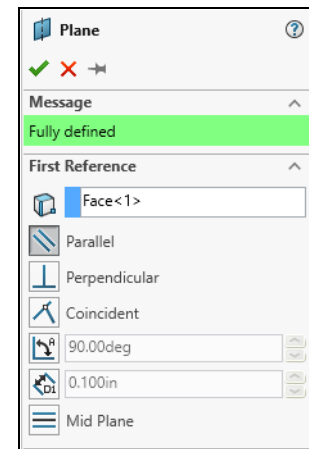
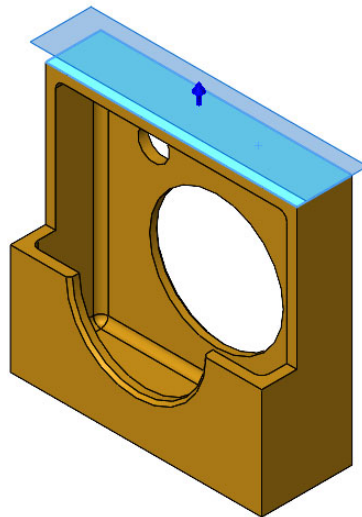

**5 Temporary axis.**

Float the cursor over the cylindrical face of the center hole, select the temporary axis that appears, and click **OK**.

The plane is parallel to the top face and passes through the center of the hole.

Name the plane hor\_ctr.

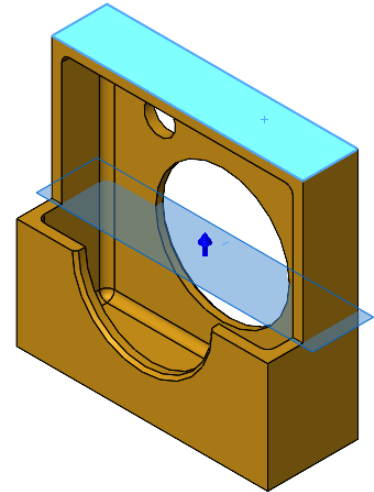
**Mirror Patterns**

The **Mirror Pattern** tool creates a copy, or instance, across a plane or planar face. The instance is dependent on the original. Changes to the original propagate down to the mirrored instance(s).

**Introducing:  
Mirror Pattern**

**Mirror Pattern** creates *one* instance of one or more features or a body across a plane or planar face. Optionally, the features can also be patterned across a secondary plane.

**Where to Find It**

- CommandManager: **Features > Linear Pattern**  > **Mirror** 
- Menu: **Insert, Pattern/Mirror, Mirror**

**6 Mirror.**

Click **Mirror** , and select the vert\_ctr plane as the **Mirror Face/Plane**.

Select the library feature Keyed Hole 1 as the **Features to Mirror**. Do not click OK yet.

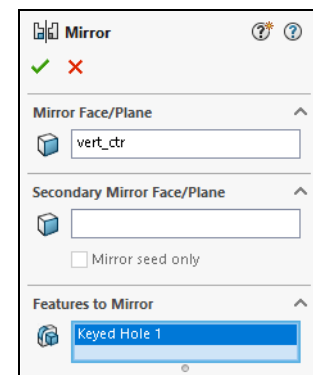
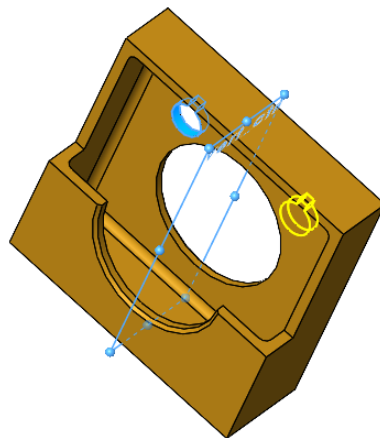

**7 Secondary Mirror.**

Select the hor\_ctr plane as the **Secondary Mirror Face/Plane**.

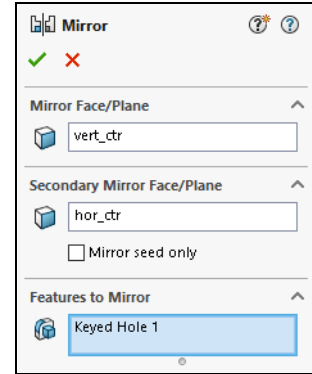
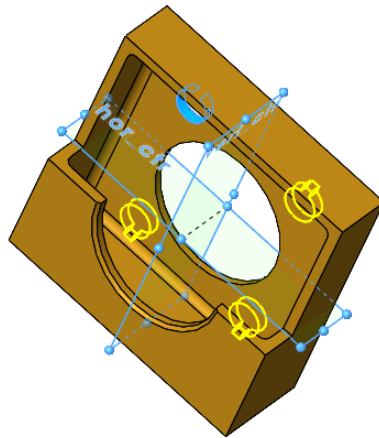

**8 Cuts into other features.**

The patterned Keyed Hole 1 feature cuts into the existing fillet and through the front wall. Changes to the feature can fix the problem.

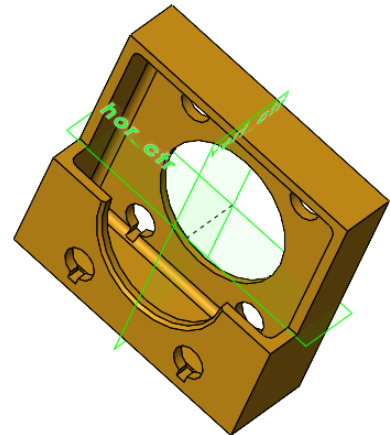

**9 Changes.**

Double-click the Keyed Hole 1 feature, and change the edge distance dimension to **0.625** as shown.

Also, change the feature extrude depth to **Up to Next** and click **OK**.  
and rebuild.

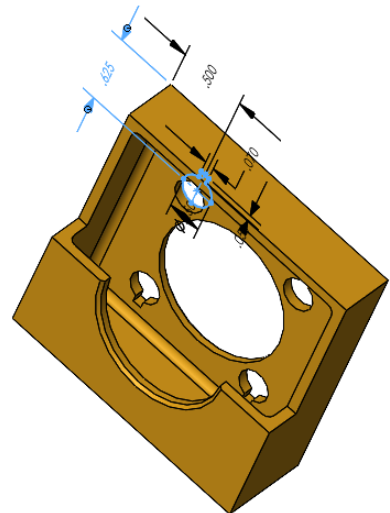

**10 Save and close the part.**

**Patterning a Solid Body**

To mirror all the geometry of a part (the body) about a common face, use the common face and the solid body.

**Note**

The **Mirror Face/Plane** must be planar.

**Where to Find It**

**Mirror** PropertyManager: **Bodies to Mirror**

**1 Open the part named **Mirror\_Body**.**

**2 Mirror.**

Click **Mirror**  and the face as shown. Click **Full preview**.

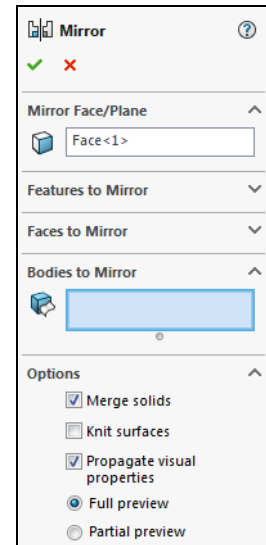
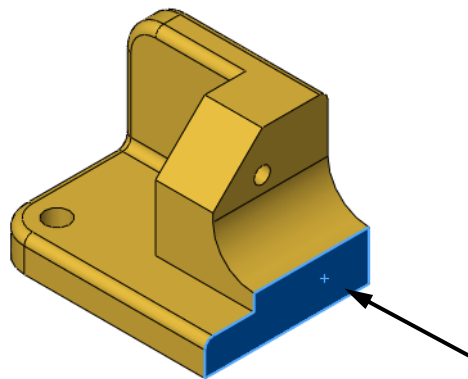

**3 Bodies to mirror.**

Click in **Bodies to Mirror**, and select the part in the graphics area. Click **OK**.

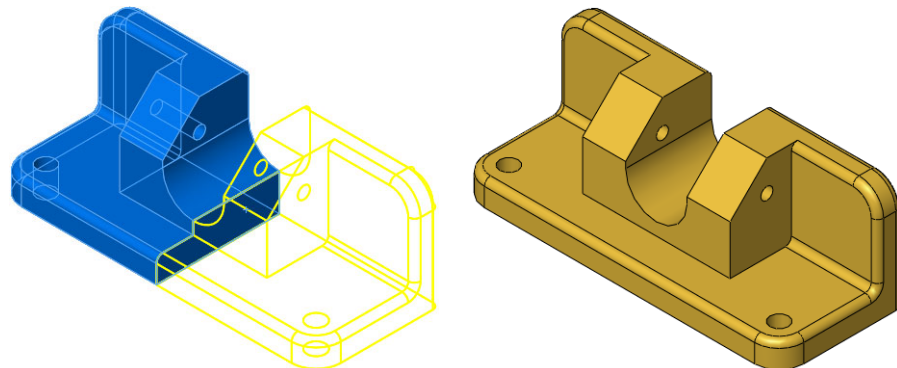

**4 Save and close the part.**

## Using Pattern Seed Only

The **Pattern Seed Only** option is used when a two direction pattern is created. The second direction defaults to patterning all geometry created by the first direction unless **Pattern Seed Only** is used to pattern only the original or seed geometry. It is commonly used to prevent overlapping results when the two directions use the same vector.

### Where to Find It

**Linear Pattern** PropertyManager: **Pattern Seed Only**

#### 1 Open the part named **Seed\_Pattern**.

#### 2 Direction 1.

Click **Linear Pattern** .

Select the edge as the **Pattern direction**. Click **Spacing and instances**, **30mm** as the **Spacing**, and **2** as the **Number of Instances**.

For **Features and Faces**, select the library feature **3\_Prong\_Plug2**.

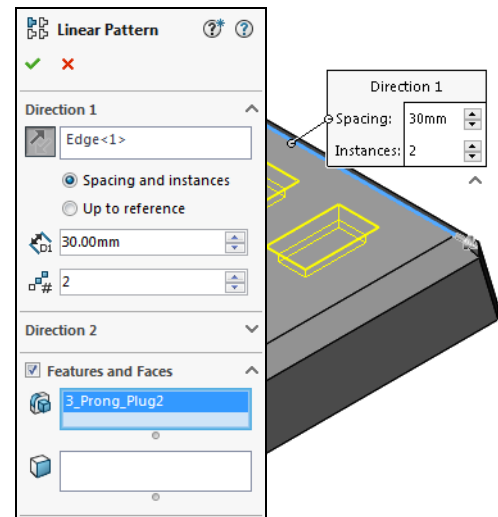

### Note

An existing pattern feature can be used as the **Features and Faces**. This enables you to pattern the pattern.

#### 3 Direction 2.

For **Direction 2**, select the edge on the opposite side as the direction, reversing the arrowhead. Set the instances to **2**, spacing to **50mm**.

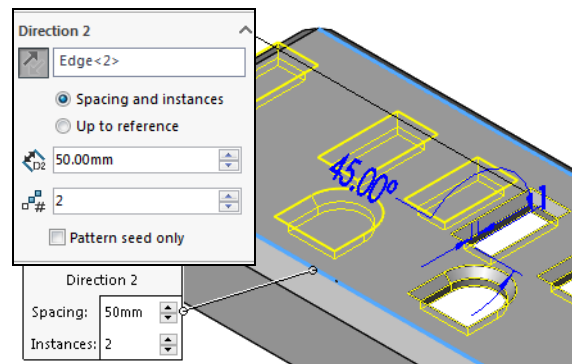

### Note

As seen in the preview, the original (seed) feature is patterned in both directions.

- 4 **Pattern seed only.**  
Click **Pattern seed only** to remove the extra instance.

Set the **Direction 2 Spacing** to **30mm** and click **OK**.

- 5 **Save and close the part.**

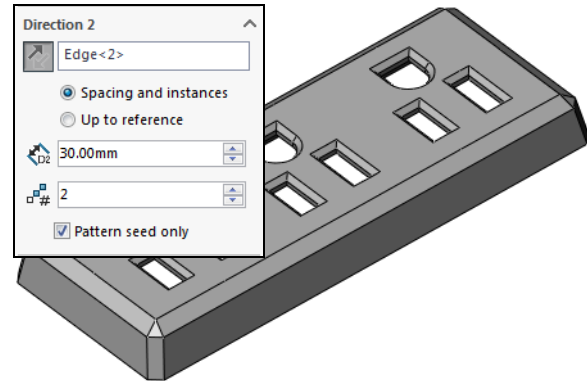

## Up To Reference

The **Up To Reference** option is used to create a linear pattern based on geometry rather than the number of instances. It can be used when the spacing is known but the number of instances is based on how many instances can fit. This example uses a part similar to the *Linear Pattern* on page 121.

The **Up To Reference** selection sets the limit. The **Selected Reference**, on the source feature, is compared to the limit. Only the instances that fall under the limit are used.

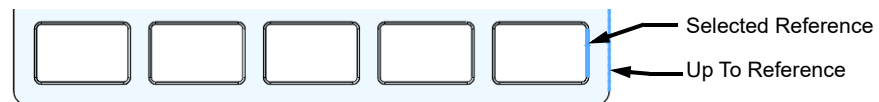

If the **Up To Reference** selection is combined with an **Offset Distance**, the offset is from the **Selected Reference**.

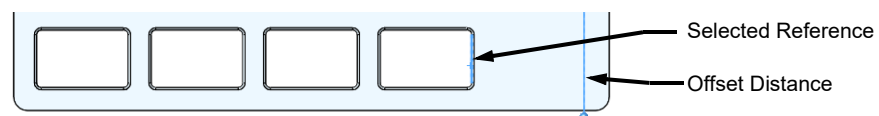

### Note

The selections can be vertices, edges, faces, or planes.

### Where to Find It

**Linear Pattern** PropertyManager: **Up to reference**

- 1 **Open the part named Up To Reference.**

**2 Select reference.**

Click **Linear Pattern**. Select the *planar face* as the **Pattern direction**. Set the **Spacing** to **30mm**. Click in **Features and Faces** and select the cut feature and fillets.

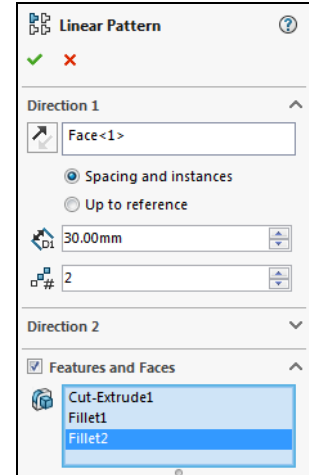
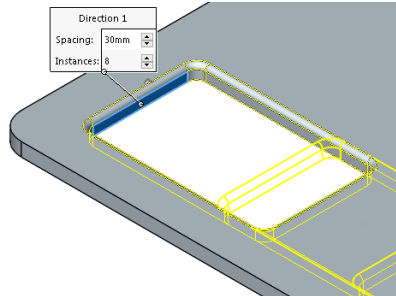

**3 Seed reference.**

Click **Up to reference** and select the (green) edge.

Click **Selected Reference** and select the (purple) edge of the seed feature as shown.

The number of instances its limited by the distance between the seed and the reference.

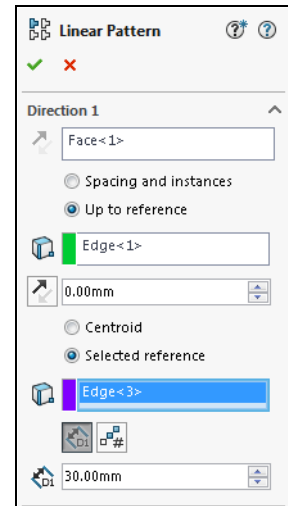
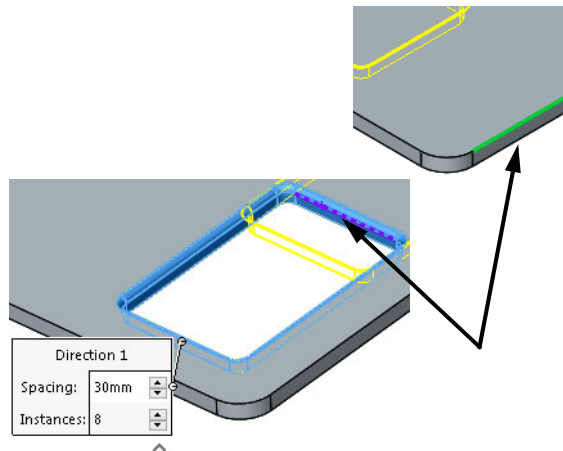

**4 Spacing and instances.**

The spacing drives the number of instances.

Change the spacing to **80mm**. Only three instances can fit at this spacing. The fourth instance would lie beyond the reference edge.

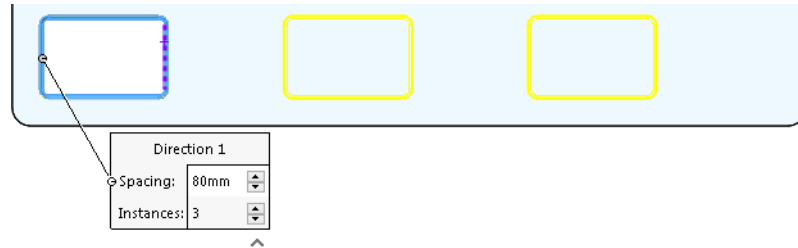

Change the spacing to **70mm**. Only four instances can fit at this spacing. The up to reference and the selected reference edges line up. Any larger value than the current one (71mm) would drop the number of instances to three.

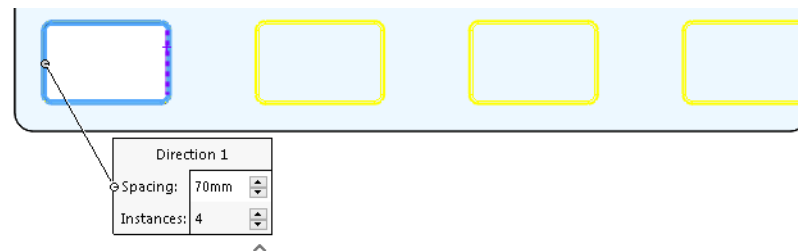

Change the spacing to **50mm**.

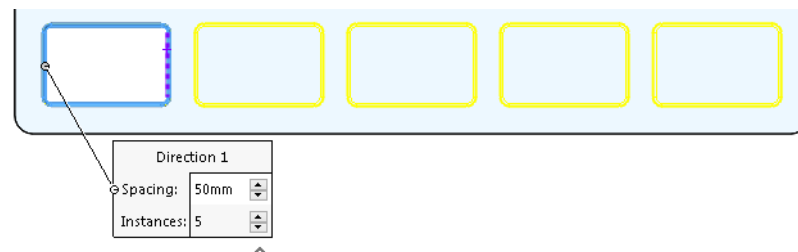
**5 Two direction pattern.**

Optionally a two direction pattern can be added using **35mm** spacing and skipped instances as shown.

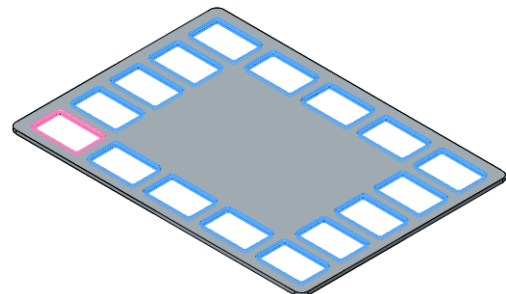
**6 Save and close the part.**

## Sketch Driven Patterns

The **Sketch Driven Patterns** tool creates copies, or instances, in an arrangement controlled by sketch points. The pattern can be based on the centroid of the seed or a selected point off the centroid.

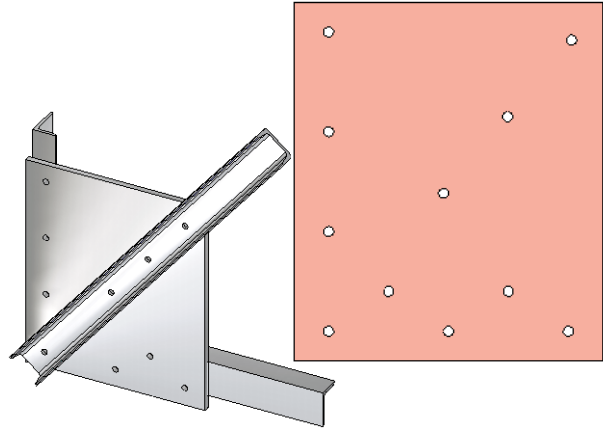

This example represents the holes in a structural steel plate.

### Introducing: Sketch Driven Pattern

**Sketch Driven Pattern** creates multiple instances based on points in a selected sketch. The sketch must exist before the pattern is created.

### Where to Find It

- CommandManager: **Features** > **Linear Pattern**  > **Sketch Driven Pattern** 
- Menu: **Insert**, **Pattern/Mirror**, **Sketch Driven Pattern**

### Tip

Only point geometry is used by the Sketch Driven pattern. Other geometry, such as construction lines, can be used to position points but will be ignored by the pattern.

---

#### 1 **Open Sketch\_Driven.**

The part contains a seed feature (Hole) and an existing linear pattern feature (Standard Linear).

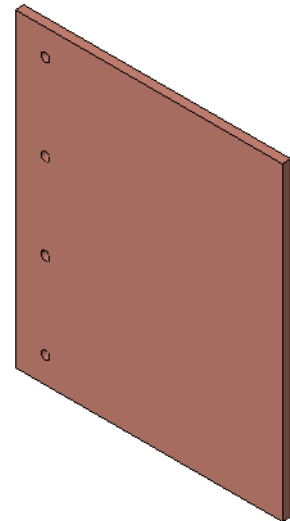

**Points**

Points are a useful type of sketch geometry used to position hole wizard holes and drive sketch driven patterns. They can be created individually or based on geometry.

**Introducing: Point**

The **Point** tool creates point entities in the active sketch. The sketch entity **Point** can be used to locate a position in a sketch that other geometry (endpoints for example) cannot.

**Where to Find It**

- CommandManager: **Sketch > Point** ▢
- Menu: **Tools, Sketch Entities, Point**
- Shortcut Menu: Right-click in the graphics area and click **Sketch Entities, Point** ▢

**Equal Spacing**

Use the **Segment** tool to create equidistant points along a line or arc/circle. To create and maintain the spacing, an **Equidistant** relation  is applied to each sketch point.

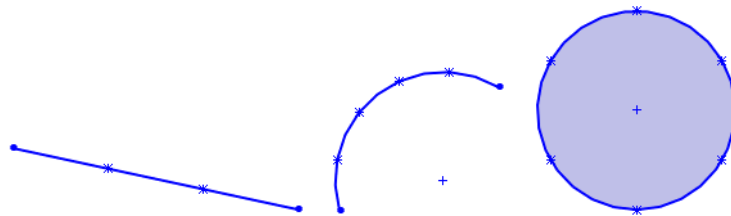
**Where to Find It**

- Menu: **Tools, Sketch Tools, Segment**

**2 Sketch with points.**

Create a new sketch on the front face of the Plate feature. Create the centerline and add the points and dimensions as shown.

Exit the sketch.

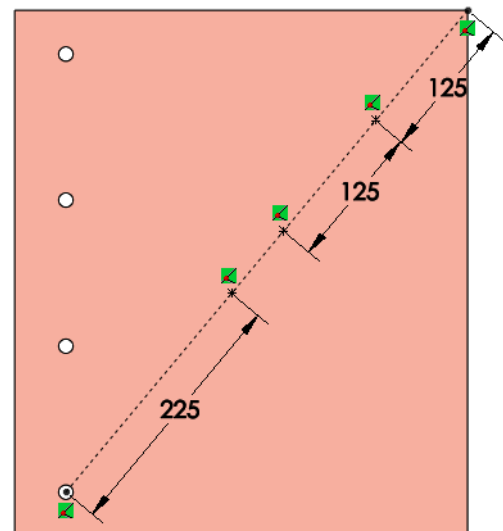

**3 Sketch driven pattern.**

Click **Sketch Driven Pattern**  and click the new sketch and the **Centroid** option. Under **Features and Faces**, select the Hole feature and click **OK**.

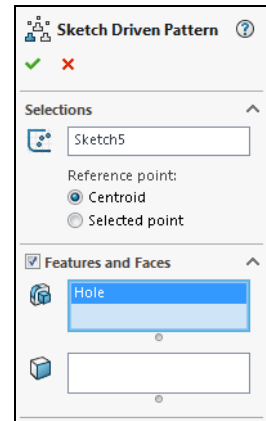
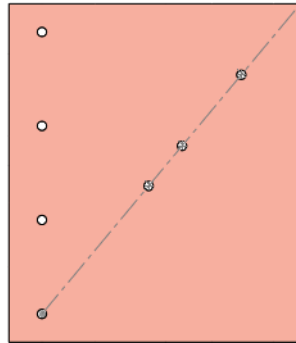

**4 Add points.**

Create another sketch and add points in the pattern shown, using inferencing to line up the rows horizontally as shown.

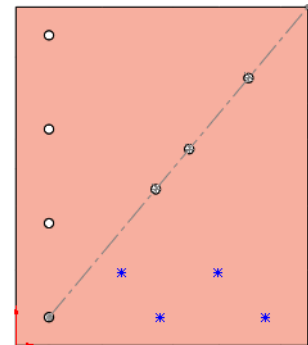

**Automatic Dimensioning of Sketches**

**Fully Define Sketch** creates relations and dimensions in a sketch. Several dimension styles, such as baseline, chain and ordinate are supported. The starting points for horizontal and vertical sets can be set.

**Note**

In some examples, shaded sketch contours are toggled off for clarity.

**Introducing: Fully Define Sketch**

**Fully Define Sketch** has options for relations to be added, dimension type, dimension start location, and dimension positions.

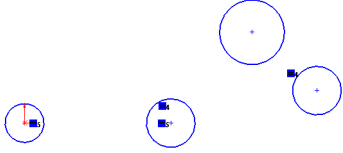
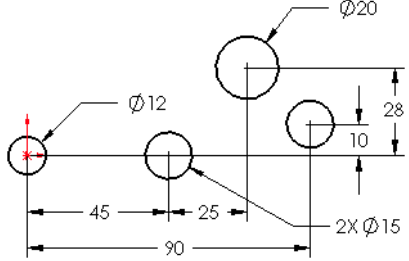
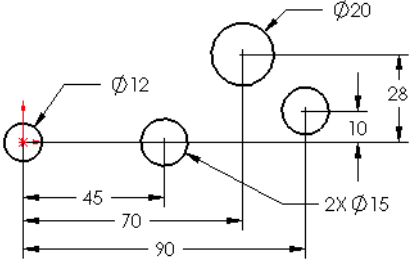
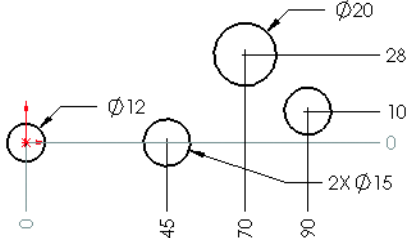
<p>Under defined sketch with geometric relations.</p>	
<p><b>Chain</b> option selected with start point at origin. <b>Note:</b> Some dimensions have been moved for clarity.</p>	
<p><b>Baseline</b> option selected with start points at origin.</p>	
<p><b>Ordinate</b> option selected with start points at origin.</p>	

**Note**

A special option **Centerline** appears when centerline geometry is used in the sketch. Dimensions can be based from the centerline.

**Where to Find It**

- Menu: **Tools, Dimensions, Fully Define Sketch**
- CommandManager: **Sketch > Display/Delete Relations**  **>**  
**Fully Define Sketch** 
- Shortcut Menu: Right-click in the graphics area and click **Fully\_Define Sketch**

**5 Relation and dimension setup.**

Click **Fully Define Sketch**.

Under **Relations** leave the default, **Select All**.

In **Dimensions**, select the endpoint of the sketch centerline as the datum for dimensions in both directions.

Set both **Schemes** to **Baseline**.

Click **Calculate** and **OK**.

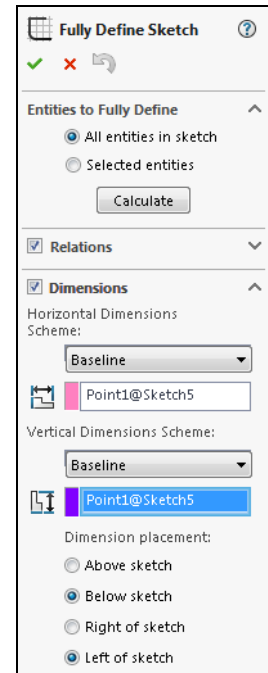
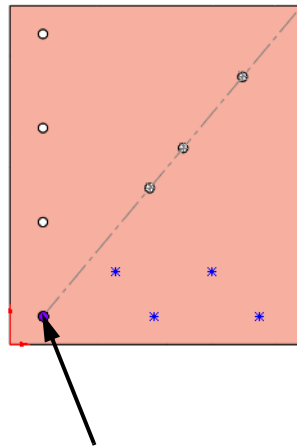

**6 Relations and dimensions.**

Horizontal relations and dimensions are added to fully define the sketch.

Set the values as shown and exit the sketch.

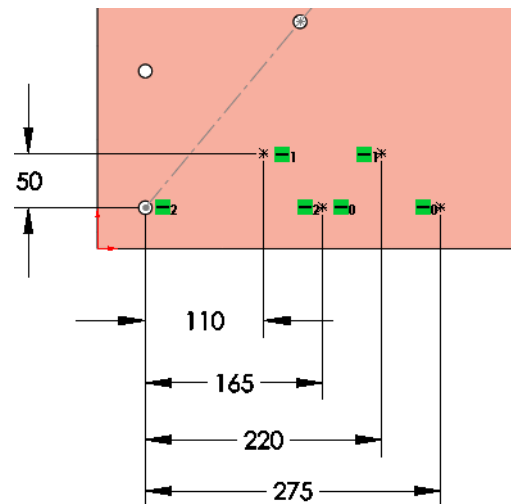

**Note**

Sketches dimensioned this way are fully defined but can be edited. You can delete and replace dimensions if required.

**7 Pattern.**

Add another sketch driven pattern using the new sketch and the same seed feature, Hole.

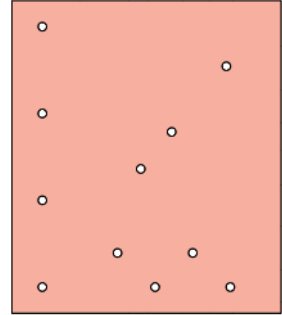
**8 Save and close the part.**

## Exercise 12: Linear Patterns

Create feature patterns in this part using a Linear Pattern with Spacing and Instances or Up to reference.

This lab uses the following skills:

- *Linear Pattern* on page 121
- *Skipping Instances* on page 123
- *Up To Reference* on page 139

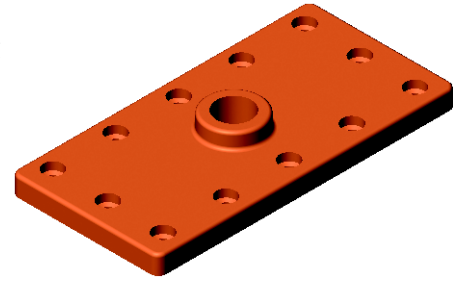

### Procedure

Open an existing part.

**1 Open the part Linear.**

The part includes the “seed” feature used in the patterns.

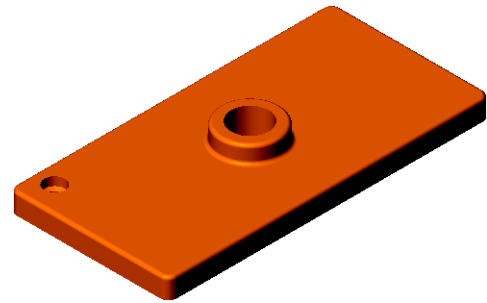

**2 Linear pattern.**

Create a pattern using the seed feature. Use the dimensions below.

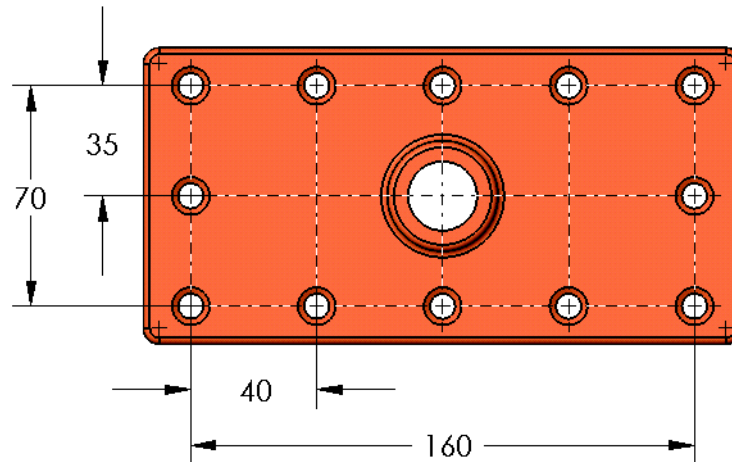

**3 Save and close the part.**

## Exercise 13: Sketch Driven Patterns

Create feature patterns using a Sketch Driven Pattern. The model is an elevator panel.

This lab uses the following skills:

- *Sketch Driven Patterns* on page 142

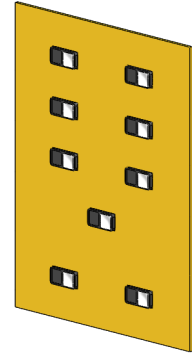

### Procedure

Open an existing part.

#### 1 Open the part **Sketch Driven Pattern**.

The part includes the “seed” feature used in the pattern.

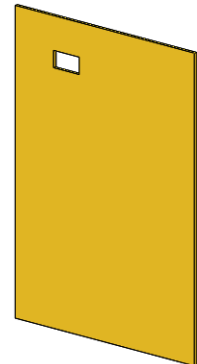

#### 2 Sketch driven pattern.

Use the dimensions shown to define the sketch. Use the sketch to create a sketch driven pattern.

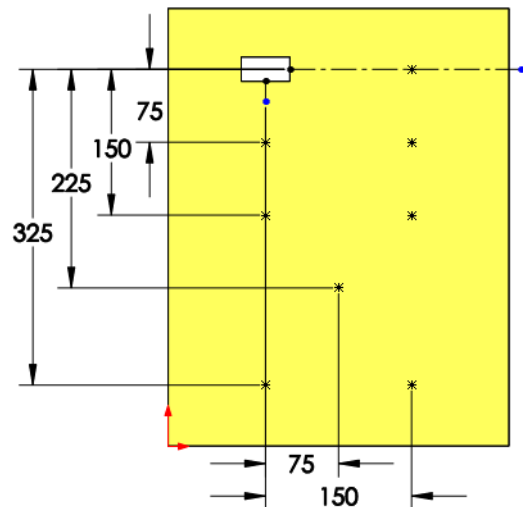

Thanks to Marcus Brown of MLC CAD Systems for submitting this example.

#### 3 Save and close the part.

## Exercise 14: Skipping Instances

Complete this part using the information and dimensions provided.

This lab reinforces the following skills:

- *Linear Pattern* on page 121
- *Skipping Instances* on page 123
- *Mirror Patterns* on page 135

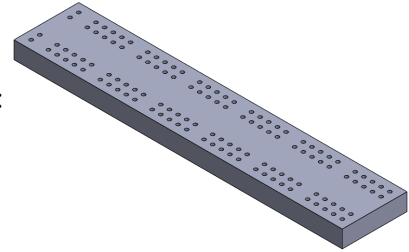

Units: **millimeters**

### Procedure

Create a new part.

#### 1 New part.

Create a new mm part

#### 2 Base feature.

Create a block

**75mmx380mmx20mm.**

It will be useful to have a plane centered along the long direction.

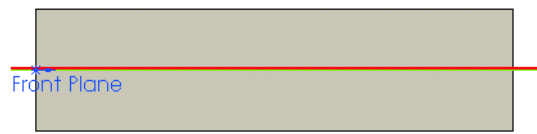

#### 3 Seed.

Create the seed feature using the Hole Wizard and an ANSI Metric drill.

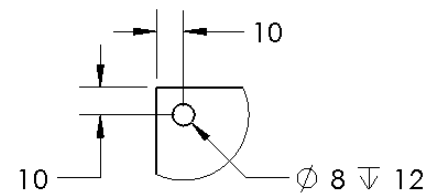

#### 4 Pattern.

Pattern the hole, skipping instances as shown in the diagram below.

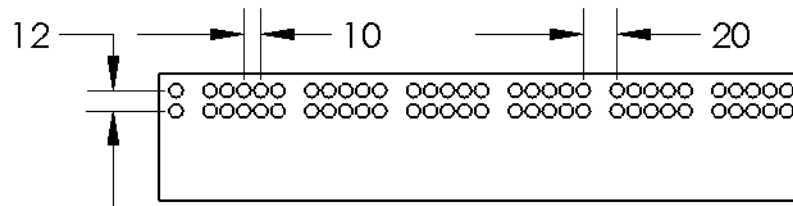

#### 5 Pattern of a pattern.

Mirror the pattern to create a symmetrical arrangement of holes.



#### 6 Change.

Change the hole to **4mm** diameter and rebuild.

#### 7 Save and close the part.

**Exercise 15:  
Linear and  
Mirror Patterns**

Complete this part using the information and dimensions provided.

This lab reinforces the following skills:

- *Linear Pattern* on page 121
- *Mirror Patterns* on page 135
- *Patterning a Solid Body* on page 137

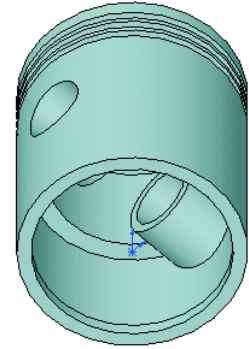
**Procedure**

Open an existing part.

**1 Open the part Linear & Mirror.****2 Linear pattern.**

Using the existing feature, create a **Linear Pattern** that results in three grooves that are spaced **0.20"**.

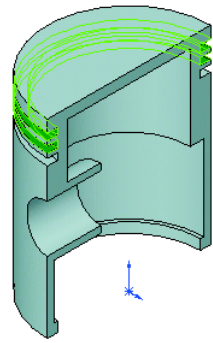
**3 Mirror features.**

Using a single pattern feature, create the duplicate boss and cut as shown.

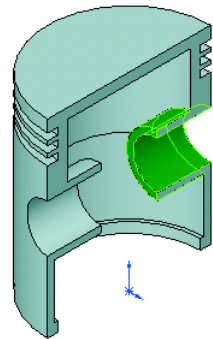
**4 Symmetry.**

Use a third pattern feature to create the full model from the half model using **Bodies to Mirror**.

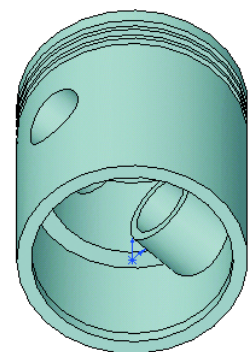
**5 Save and close the part.**

## Exercise 16: Mirror Body

Complete this part using the information and dimensions provided.

This lab reinforces the following skills:

- *Mirror Patterns* on page 135
- *Patterning a Solid Body* on page 137

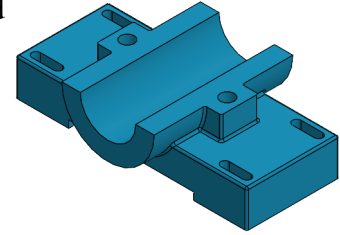

### Procedure

Open an existing part.

**1 Open the part **Mirror Body**.**

At the feature recognition message, click **No**.

**2 Mirror body.**

Using the existing solid body, mirror about one, then two planar faces of the model.

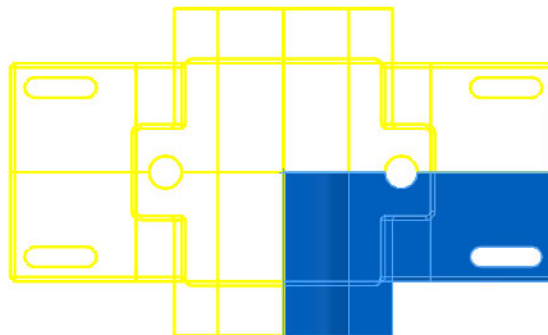
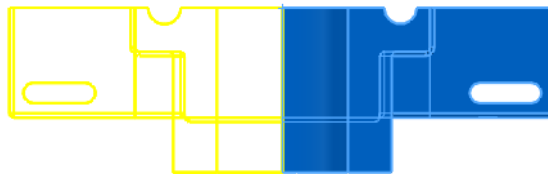
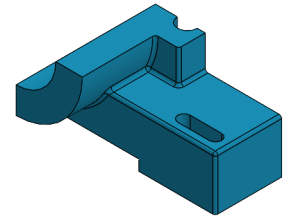

**3 Save and close the part.**

**Exercise 17:  
Circular  
Patterns**

Complete this part using the information and dimensions provided.

This lab reinforces the following skills:

- *Circular Patterns* on page 127

**Procedure**

Open the existing part *Circular*. Use an equally spaced circular pattern to pattern the cut and fillet for 12 total instances.

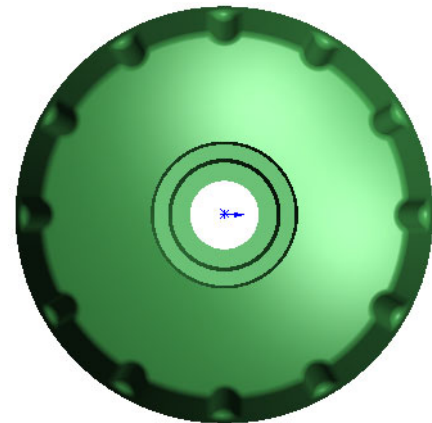
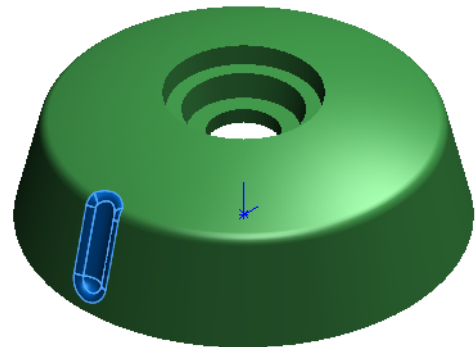
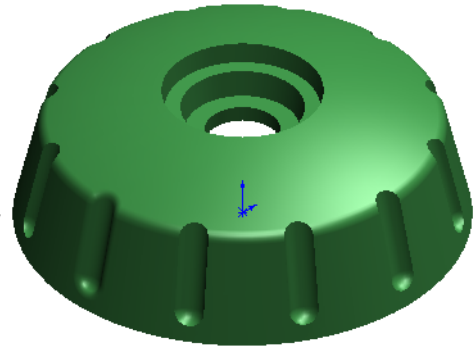

### Exercise 18: Axes and Multiple Patterns

Complete this part using the information and dimensions provided.

This lab reinforces the following skills:

- *Axes* on page 128
- *Linear Pattern* on page 121
- *Circular Patterns* on page 127
- *Sketch Driven Patterns* on page 142

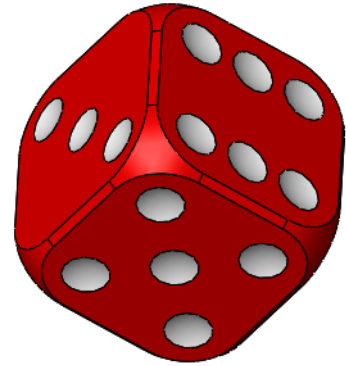

### Procedure

Open the existing part Single Die. Use the drawing below to pattern the Dot feature on the sides as shown.

The face colors are used to help distinguish between the individual faces. See step 4 on page 156 for *removing* the colors.

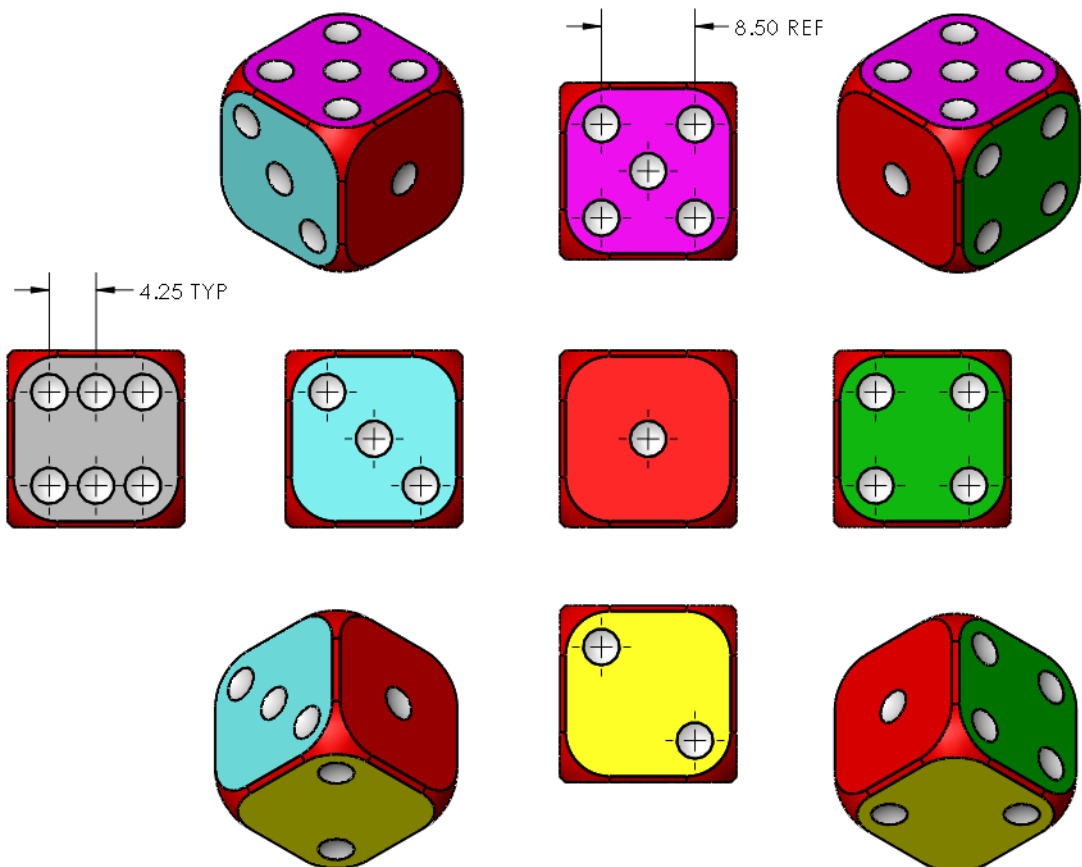

### Note

Orient the part as shown in each step before starting work.

**1 Axes.**

Create an axis using the Front and Right planes.

Create two more axes using the Top and Front and the Right and Top reference planes.

All three axes should pass through the cube center.

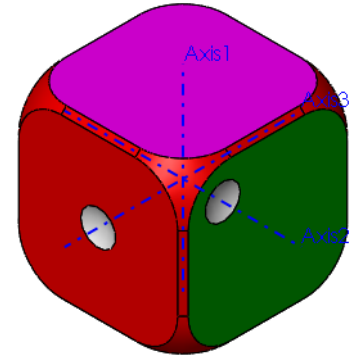
**2 Side Two.**

Using a **Linear Pattern** with **Instances to Skip**, create the “two” side.

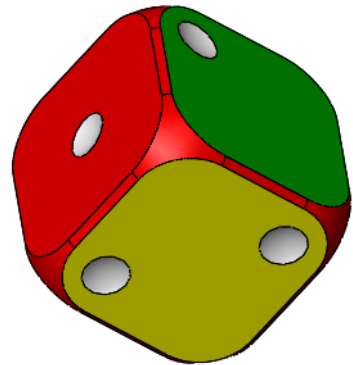
**3 Remaining sides.**

Complete the remaining sides using the descriptions of each one listed below.

- **Side Three**

Use a **Circular Pattern** with an axis to create a cut at the center of the face.

Create a sketch and use a **Sketch Driven Pattern** with **Faces to Pattern** to create the remaining cuts.

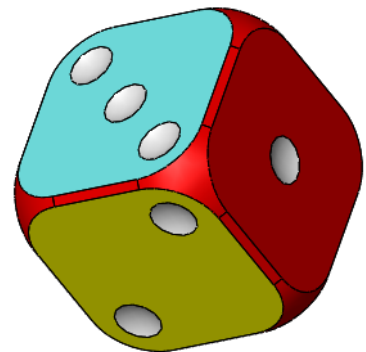

- **Side Four**

Use a **Circular Pattern** with an axis to create the remaining cuts.

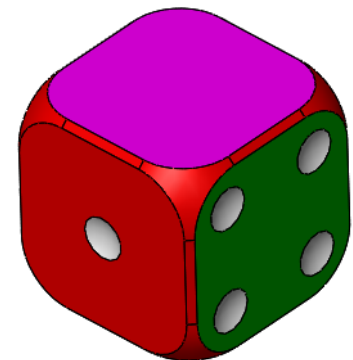

■ **Side Five**

Use a procedure similar to that of side three.

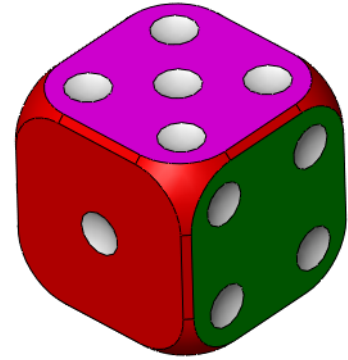

■ **Side Six**

Use a **Circular Pattern** with an axis to create a cut at the corner of the face.

Use a **Linear Pattern** to create the remaining cuts.

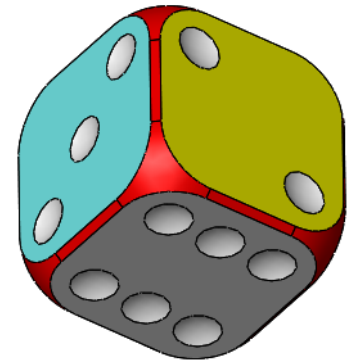

4 **(Optional) Remove face colors.**

Marking faces with colors is a modeling method that helps with face recognition. The face colors can be removed after the modeling is complete. Follow these steps:

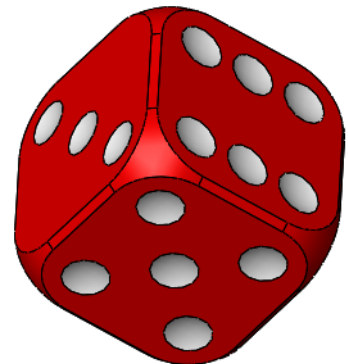

1. Click **Edit Appearance**  from the Heads-up View toolbar.
2. Clear **Select Geometry** by right-clicking **Clear Selections**.
3. Click **Select Faces** and select the non-red faces.
4. Click **Remove Appearance** and **OK**.

5 **Save and close the part.**

# Lesson 5

## Revolved Features

Upon successful completion of this lesson, you will be able to:

- Create revolved features.
- Apply special dimensioning techniques to sketches for revolved features.
- Use the multibody solid technique.
- Create a sweep feature.
- Calculate the physical properties of a part.
- Perform rudimentary, first pass stress analysis.

## Case Study: Handwheel

The handwheel requires the creation of revolved features, circular patterns and sweep features.

Also included in this lesson are some basic analysis tools.

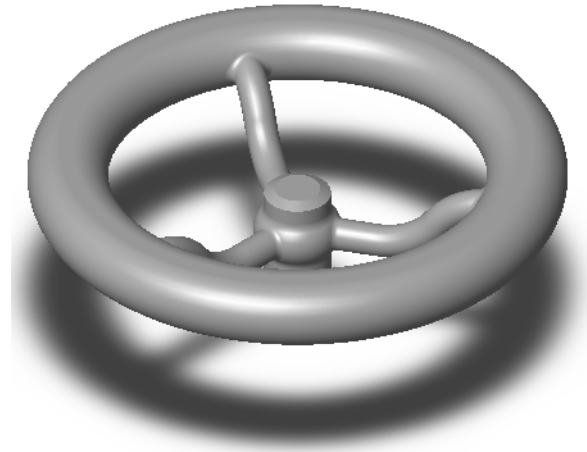

## Stages in the Process

Some key stages in the modeling process of this part are shown in the following list.

- **Design intent**  
The part's design intent is outlined and explained.
- **Revolved features**  
The center of the part is the Hub, a revolved shape. It will be created from a sketch with a construction line as the axis of revolution.
- **Multibody solids**  
Create two discrete solids, the Hub and the Rim, connecting and merging them using a third solid, the Spoke.
- **Sweep features**  
The Spoke feature is created using a sweep feature, a combination of two sketches that defines a sweep profile moving along a sweep path.
- **Analysis**  
Using analysis tools, you can perform basic analysis functions such as mass properties calculations and first-pass stress analyses. Based on the results, you can make changes to the part's design.

## Design Intent

The design intent of this part is shown below:

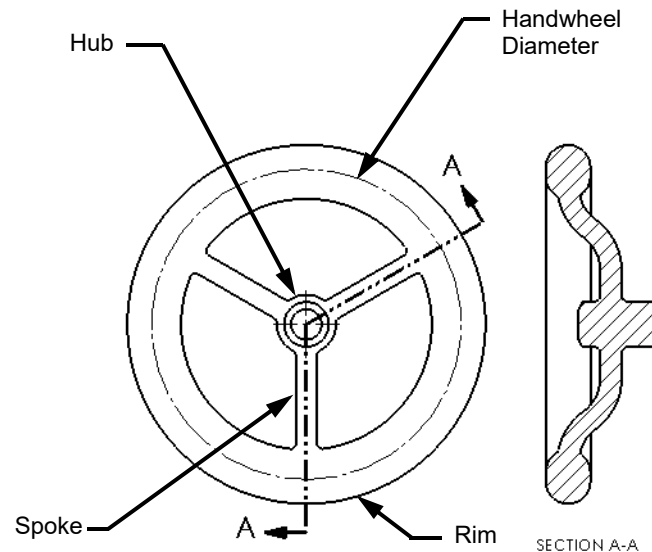

- Spokes must be evenly spaced.
- The center of the rim of the handwheel lies at the end of the spoke.
- The hub and the rim share the same center.
- The spokes pass through the center of the hub.

## Revolved Features

The Hub is a revolved feature that is created by revolving geometry around an axis. Revolved features require axisymmetric geometry and a line (used as the axis) in the sketch. This revolved feature will be used as the center of the wheel. Under the right circumstances, a sketch line or an edge may also be used as the centerline.

### Procedure

To begin this case study:

- 1 **Create a new part using the Part\_MM template.**  
Save the part as Handwheel.

### Sketch Geometry of the Revolved Feature

Geometry for the revolved feature is created using the same tools and methods as extruded features. In this case, lines and arcs will be used to form the shape and a centerline is used as the axis of revolution.

- 2 **Rectangle.**  
Select the Right Plane and click **Sketch**.  
Create a rectangle from the Origin as shown.

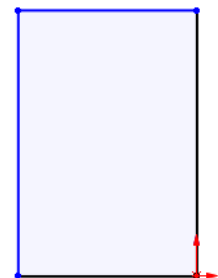

**3 Convert to construction.**

Select the vertical line shown and click **For Construction**. The line is converted into a construction line.

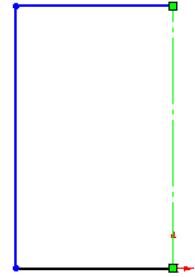

The shading is removed because this is no longer a closed contour.



**Introducing:  
3 Point Arc**

The **3 Point Arc** option enables you to create an arc based on three points: the two endpoints followed by a point on the curve.

**Where to Find It**

- CommandManager: **Sketch > Centerpoint Arc**  > **3 Point Arc** 
- Menu: **Tools, Sketch Entities, 3 Point Arc**
- Shortcut Menu: Right-click in the graphics area and click **Sketch Entities, 3 Point Arc** 

**4 Insert 3 Point Arc.**

Click **3 Point Arc** .

Begin the arc by positioning the cursor on the left vertical line and dragging downwards along that edge. Release the mouse button and then select and drag the point on the curve away from the sketch.

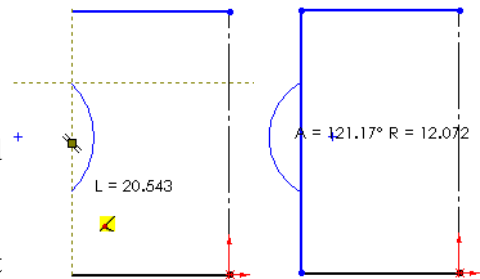

**5 Trimming.**

Use the **Trim** tool with the **Power Trim** option and trim away the portion of the line inside the arc.

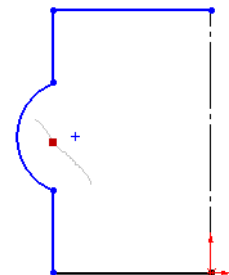

## Rules Governing Sketches of Revolved Features

In addition to the general rules governing sketches that were listed in *Lesson 2: Introduction to Sketching*, some special rules apply to sketches of revolved features:

- A centerline, axis, sketch line or linear edge must be specified as the axis of revolution.
- The sketch must not cross the axis.

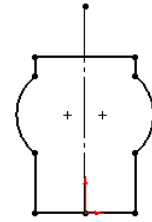

Not Valid

## Special Dimensioning Techniques

Revolved geometry is dimensioned like any other with one additional option. Dimensions that measure diameters on the finished feature can be changed from linear to diameter dimensions.

We will also dimension to the outside of the arc in the sketch, rather than the center point which is the default.

### 6 Arc dimension.

Dimension the arc by selecting the vertical line and then **Shift**-selecting the circumference of the arc. The result is a dimension between the line and the tangent of the arc.

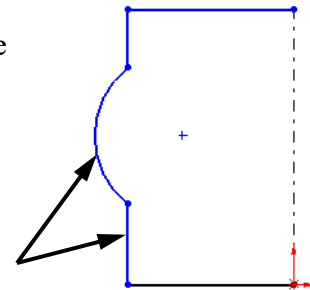

### 7 Finished dimension.

Change the **Value** to **4mm**.

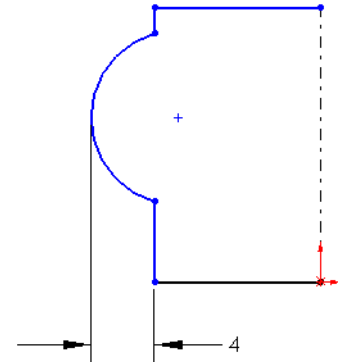

### 8 Dimensions.

Add the following dimensions to the sketch.

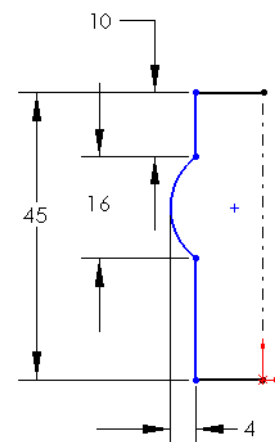

## Diameter Dimensions

Some dimensions should be doubled dimensions in the finished revolved feature. For these dimensions, always select the centerline (axis of revolution) as one of the picks. You then have your choice of either a radius or diameter dimension, depending on where you place the dimension text. If you don't pick the centerline, you won't be able to change the dimension to a diameter.

### Note

This option is available only if a centerline is used as the axis of revolution. Doubled dimensions are *not* restricted to use in revolved feature sketches.

#### 9 Dimension to centerline.

Dimension between the centerline and the outer vertical edge to create a horizontal linear dimension.

*Do not* click to place the dimension text just yet.

Notice the preview. If you place the text now, you will get a radius dimension.

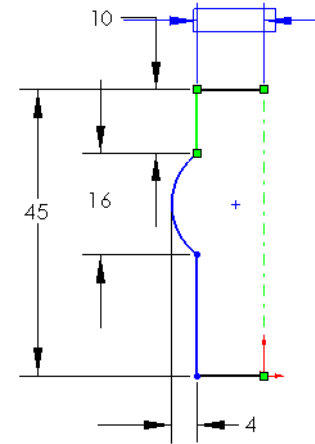

#### 10 Move the cursor.

Move the cursor to the right of the centerline. The preview changes to a diameter dimension.

Click to place the dimension text. Change the value to **25mm** and press **Enter**.

Normally, a diameter dimension should have a diameter symbol preceding it, thus:  $\varnothing 25$ . When the revolved feature is created from the sketch, the system will automatically add the diameter symbol to the **25mm** dimension.

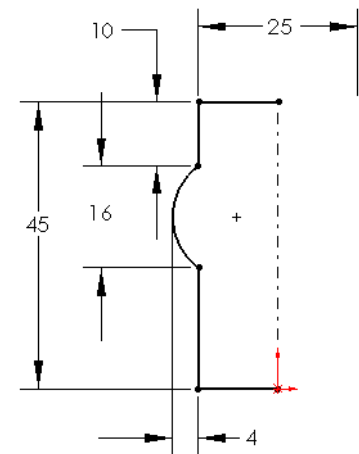

### Note

If you inadvertently place the dimension text in the wrong place, and get a radius dimension instead of a diameter, you can fix it. Click the dimension, and click the Leaders tab of the **DIMENSION**

PropertyManager. Click the **Diameter** button  to make the dimension a diameter dimension.

**Creating the Revolved Feature****Introducing: Revolved Feature**

Once the sketch is completed, it can be made into a revolved feature. The process is simple, and a full (360°) revolution is almost automatic.

The **Revolve** option enables you to create a feature from an axisymmetric sketch and an axis. This feature can be a base, boss or cut feature. The axis can be a centerline, line, linear edge, axis or temporary axis. If a single centerline is present in the profile, it is used automatically. If more than one is present, you must select it.

**Where to Find It**

- CommandManager: **Features > Revolved Boss/Base** 
- Menu: **Insert, Boss/Base, Revolve**

**11 Make the feature.**

Click **Revolved Boss/Base** .

A message will appear indicating that the sketch is an open contour and asking if you want to close the contour automatically. Click **Yes**.

Use the settings as shown.

- **Direction1 = Blind**
-  (Angle) = 360°

Click **OK**  to create the feature.

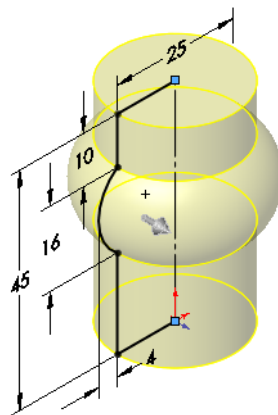
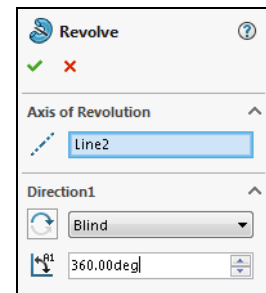
**12 Finished feature.**

The solid revolved feature is created as the first feature of the part.

Rename it Hub.

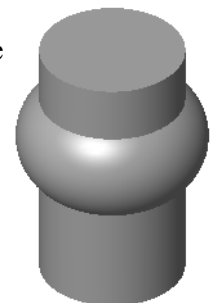

### 13 Edit the sketch.

Click a face of the Hub. Click the sketch Sketch1 from the **Selection Breadcrumbs** and click **Edit Sketch**.

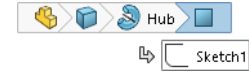

#### Note

You can right-click the feature in the FeatureManager design tree and achieve the same result.



### 14 Normal To.

Click **Normal To**  to change the view normal to the sketch. Do this to see its true size and shape.

#### Introducing: Sketch Fillet

**Sketch Fillets** can be used to trim and add tangent arcs in a single step. If the corner has been trimmed, select the vertex point to add the fillet.

#### Where to Find It

- CommandManager: **Sketch > Sketch Fillet** 
- Menu: **Tools, Sketch Tools, Fillet**
- Shortcut Menu: Right-click in the graphics area and click **Sketch Tools, Sketch Fillet** 

### 15 Fillet settings.

Click **Sketch Fillet**  and set the value to **5mm**. Make sure the **Keep constrained corners** option is checked.

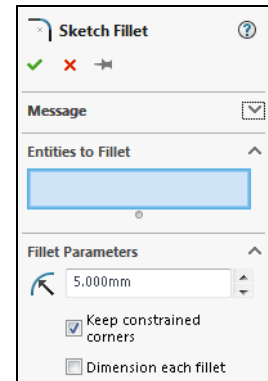

### 16 Selections.

Select both endpoints of the arc and click **OK**.

The dimension drives both but only appears once, at the last selection.

**Virtual Sharp** symbols are added where the corners were. These symbols represent the missing corners and can be dimensioned to or used within relations.

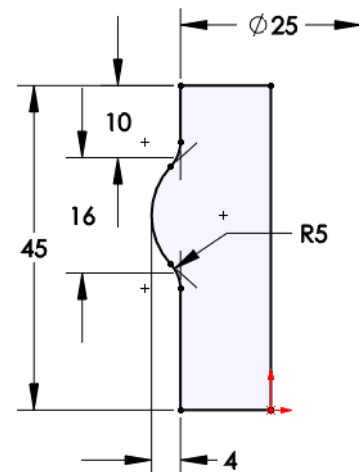

#### Note

Floating over an endpoint shows a preview of the fillet.

**17 Exit the sketch.**

Exit the sketch to cause the changes to take effect.

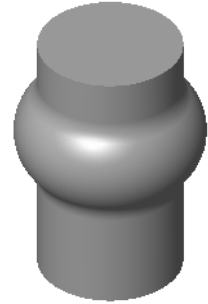

**Building the Rim**

The Rim of the Handwheel is another revolved feature. It too is revolved 360°. The profile of the Rim is a slot shape.

The Rim will be created as a separate solid body, not merged to the Hub.

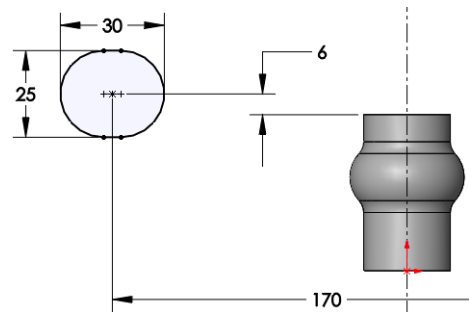

**Slots**



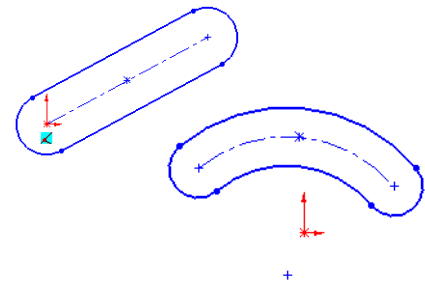

Straight and arc **Slots** are common shapes based on lines and arcs. The slot is a single entity which is composed of lines, arcs, construction geometry and points.

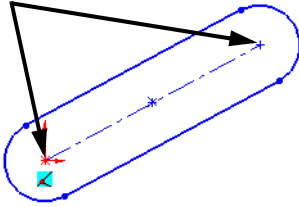

**Introducing: Slots**

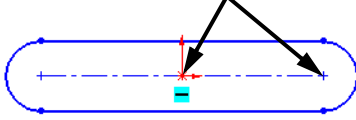
The **Slot** tool is used to create straight and arc slot shapes based on different criteria. There are two types based on lines and two types based on arcs. All slot types have the option to create dimensions with the geometry. The following types are available:

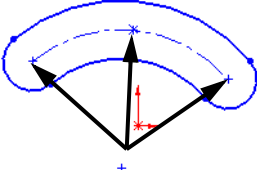
Slot Type	Resulting Geometry
<p><b>Straight Slot</b> </p>	<p>The <b>Straight Slot</b> is created by locating the centerpoints of the arcs and then dragging outwards to create the width.</p> 

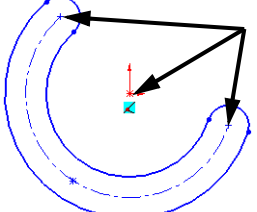
Slot Type	Resulting Geometry
<p><b>Centerpoint Straight Slot</b> </p>	<p>The <b>Centerpoint Straight Slot</b> is created by locating the geometric center, one of the arc centerpoints and then dragging outwards to create the width.</p> 
<p><b>3 Point Arc Slot</b> </p>	<p>The <b>3 Point Arc Slot</b> is created like a <b>3 Point Arc</b> (see <i>Introducing: 3 Point Arc</i> on page 160) and then dragging outwards to create the width.</p> 
<p><b>Centerpoint Arc Slot</b> </p>	<p>The <b>Centerpoint Arc Slot</b> is created like a <b>Centerpoint Arc</b> (see <i>Sketch Geometry</i> on page 33) and then dragging outwards to create the width.</p> 

**Where to Find It**

- CommandManager: **Sketch > Straight Slot** ,
- Centerpoint Straight Slot** 
- Menu: **Tools, Sketch Entities, Centerpoint Straight Slot**
- Shortcut Menu: Right-click in the graphics area and click **Sketch Entities, Centerpoint Straight Slot** 

**18 Sketch.**

Create a new sketch on the Right plane. Orient the model in the same direction.

**19 Centerpoint Straight Slot.**

Click **Centerpoint Straight Slot** . Click **Add dimensions** and **Overall Length**. Click the location of the centerpoint and a location horizontally to the right. A third click sets the slot width. Click **OK** and set the dimension values as shown.

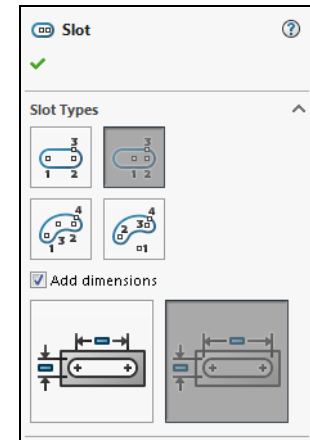
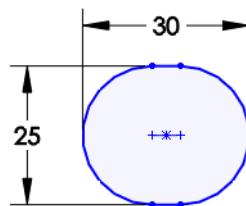
**Tip**

The dimensions are added automatically if the **Add dimensions** option is clicked.

**20 Rotation axis.**

Add a centerline using **Centerline** , setting **Vertical** and **Infinite length**. Place the line at the origin. This will be the axis of revolution for the revolved feature.

Add a diameter dimension from the centerline to the centerpoint of the slot, and from the slot centerline to the top edge of the Hub.

The sketch is now fully defined.

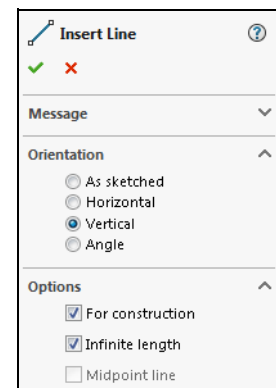
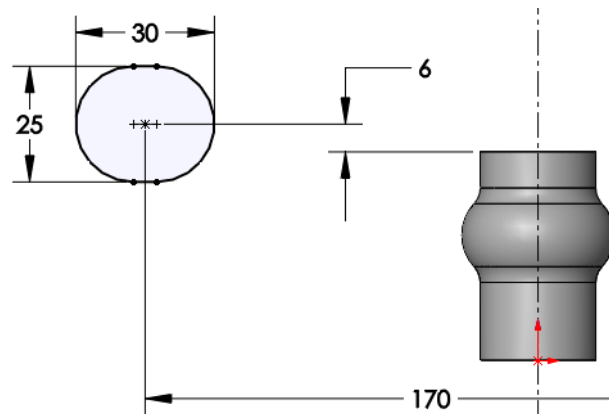

### Potential Ambiguity

If the sketch contains more than one centerline, the system will not know which centerline is intended to be the axis of revolution. The centerline to be used can be selected either before or after selecting the **Revolve** tool.

### 21 Completed feature.

Select the infinite vertical centerline. Click **Boss/Base, Revolve** . Use an angle of **360°**. Rename the feature to **Rim**.

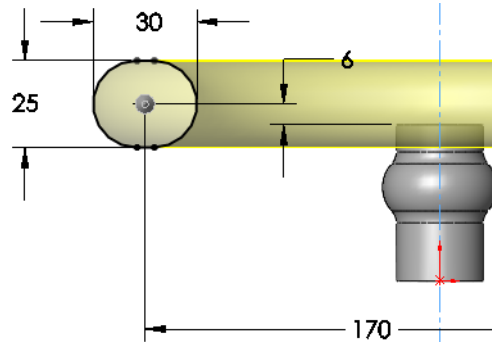

### Multibody Solids

Multibody solids occur when there is more than one solid body in a part. In cases where discrete features are separated by a distance, this can be the most efficient method in designing a part.

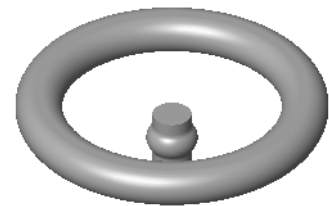

The Solid Bodies folder holds the bodies and also lists how many bodies are currently housed in the folder (2). The bodies can be merged or combined later to create a single solid body.

For more information on multibody parts, see the *Advanced Part Modeling* training manual.

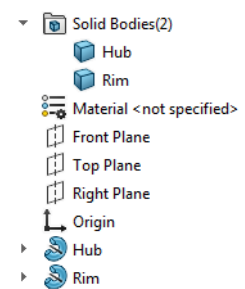

### Building the Spoke

The Spoke feature will be created using a **Sweep** feature that requires two sketches: a profile and a path. The sweep pushes a closed contour profile along an open contour path. The path is sketched using lines and tangent arcs. The profile is sketched using an ellipse. The feature will bridge the space between the existing Hub and Rim features and combine them into a single solid body.

The Spoke feature is important because it will be patterned to create any number of evenly spaced spokes.

**22 Open the Display Pane.**

In the FeatureManager design tree, click  to expand the **Display Pane**. It contains columns which can be used to change display properties of items in the tree.

**23 Search.**

Use the FeatureManager Search box  to search by the starting letters of a name or some portion of the name.

Type *ske* into the FeatureManager Design Tree filter to show the sketches of the Hub and Rim.

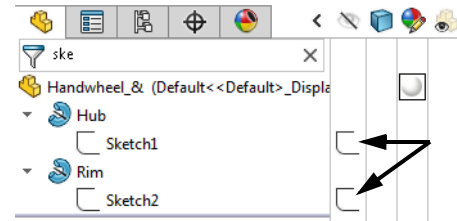

Click on the sketch icon for the Hub to show it. Repeat for the Rim.

**24 Setup.**

Create a new sketch on the Right plane and change the display to **Hidden Lines Visible**.

**25 Sketch line.**

Sketch a horizontal **Line** running from the centerline inside the Hub boundaries.

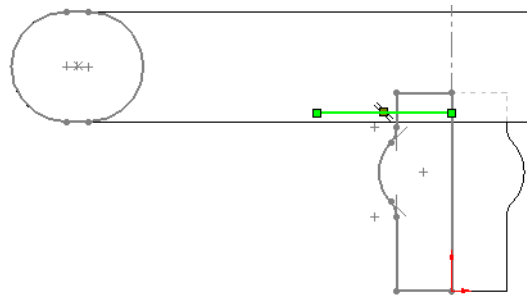
**26 Tangent arc.**

Create a **Tangent Arc** from the line endpoint in the direction shown. The actual values are not important as you sketch. They will be defined by dimensions later.

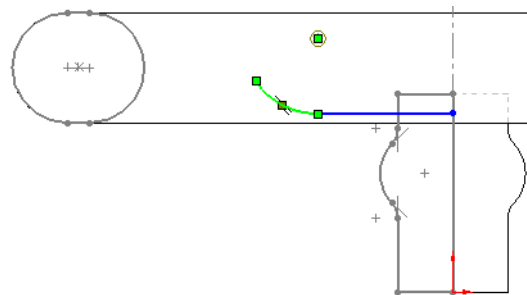
**27 Connecting tangent arc.**

With **Tangent Arc** still selected, continue sketching by using the previous arc's endpoint as a start. Sketch this arc tangent to the first, ending at a horizontal tangency position.

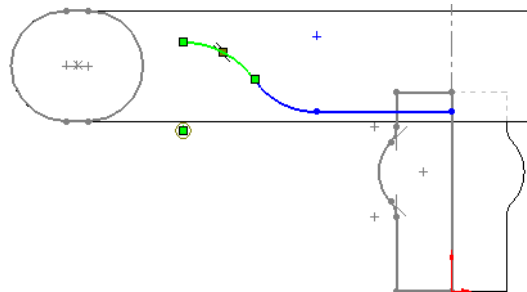

**Tip**

When the vertical inference line coincides with the arc's center, the tangent of the arc is horizontal.

**28 Horizontal line.**

Sketch a final line. It is horizontal, with its length to be determined by relations and dimensions.

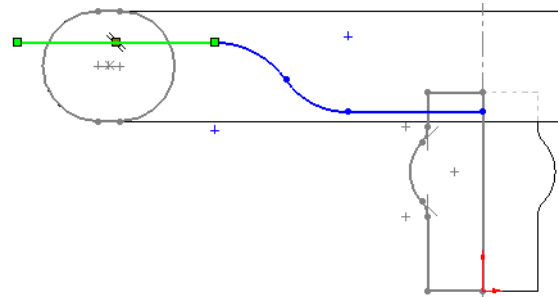

**29 Relations.**

Drag and drop the left endpoint of the line onto the centerpoint of the Rim sketch. A **Coincident** relation is added.

Add another relation between the line at the opposite end and the centerpoint of the arc.

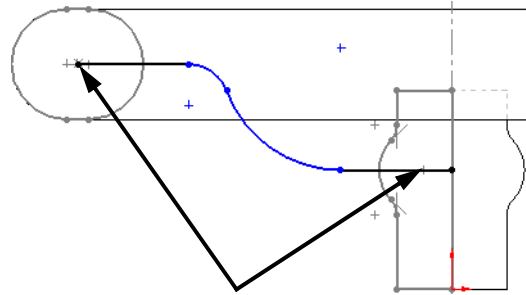

**30 Return to a shaded display.**

Click **Shaded**  to change the display.

**31 Fully define sketch.**

Add an **Equal** relation to the arcs and add dimensions.

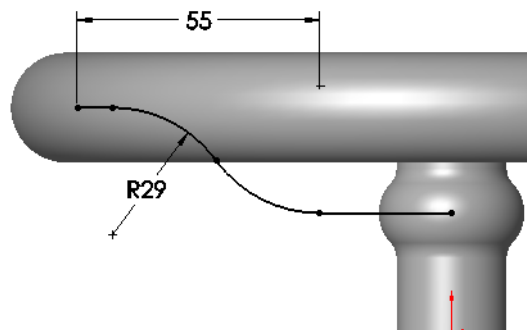

**Tip**

Picking end points and centers allows for more options when creating the dimensions.

**32 Exit sketch.**

Click **Exit Sketch**  to close the sketch without using it in a feature. Hide the Hub and Rim sketches.

**Introducing:  
Insert Ellipse**

Sketching an ellipse is similar to sketching a circle. Position the cursor where you want the center and drag the mouse to establish the length of the major axis. Then release the mouse button. Next, drag the outline of the ellipse to establish the length of the minor axis.

**Important!**

To fully define an ellipse you must dimension or otherwise constrain the lengths of the major and minor axes, and *also* constrain the orientation of one of the two axes. One way to do this is with a **Horizontal** relation between the ellipse center and the end of the major axis.

**Where to Find It**

- CommandManager: **Sketch > Ellipse** 
- Menu: **Tools, Sketch Entities, Ellipse**
- Shortcut Menu: Right-click in the graphics area and click **Sketch Entities, Ellipse** 

**33 Ellipse.**

Create a new sketch on the Front plane. Click **Ellipse**  and position the centerpoint at the end of the line. Move away from the center and position the major and minor axes with additional clicks.

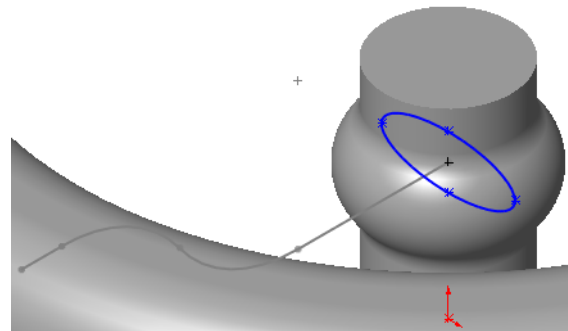
**34 Relations and dimensions.**

Add relations to make the centerpoint and one of the major axis points **Horizontal**. Add the dimensions as shown.

Exit the sketch.

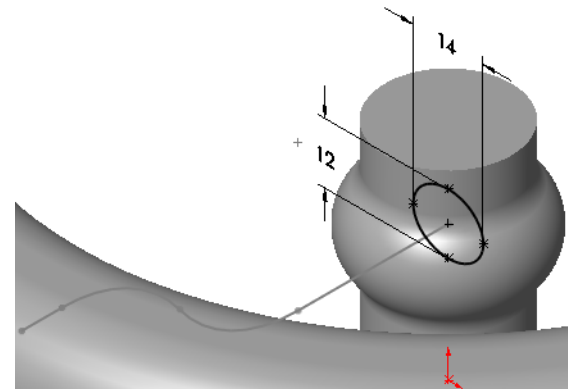

**Introducing: Sweep**

**Sweep** creates a feature from two sketches: a sweep profile and sweep path. The profile is moved along the path, creating the feature.

**Note**

The **Circular Profile** option uses a path sketch with a circle diameter.

**Where to Find It**

- CommandManager: **Features > Swept Boss/Base** 
- Menu: **Insert, Base/Boss, Sweep**

**Note**

The **Sweep** command is covered in depth in the *Advanced Part Modeling* course.

**35 Sweep.**

Click **Swept Boss/Base** . Select the closed contour sketch as the **Profile** and the open contour sketch as the **Path**.

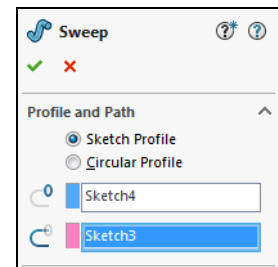
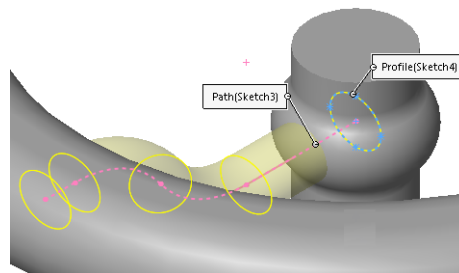

Click **OK**.

**36 Results.**

Name the new feature **Spoke**. There is a single solid body after the new feature is merged.

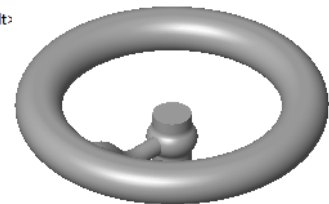
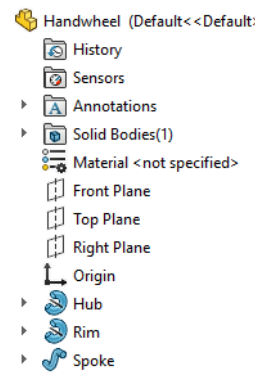

**37 Pattern the Spoke.**

Click **Circular Pattern** . Select the cylindrical face as the center of rotation for the pattern. Using the Spoke, set the **Number of Instances** to **3** with **Equal spacing**.

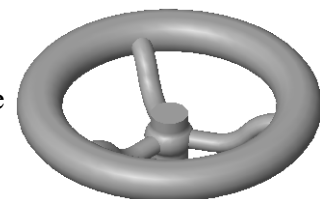

**Rotate View**

**Rotate View**  enables you to rotate the view of the model freely. To restrict that motion, you can choose an axis, a line or edge, a vertex, or a plane. Click the **Rotate View** tool and the center axis.

The same result can be obtained using the middle mouse button rotation. Select the entity to rotate about using the middle mouse button, then drag with the middle mouse button.

**38 Rotate.**

Rotate about the Handwheel center axis by clicking a circular edge or cylindrical face of the Hub with the middle mouse button. Then Drag the middle mouse button to activate the rotate command.

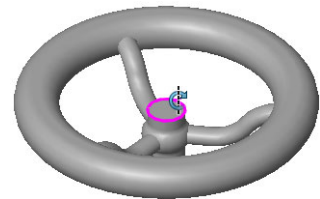

**Edge Selection**

The **Edge Selection** toolbar can assist in selecting combinations of edges that are related to selected edge in some way. It is a multiple edge selection method that can be used in combination with any other selection methods.

For example, selecting this single edge offers several different combinations of edges (shown as blue and dashed), each under a different icon and name.

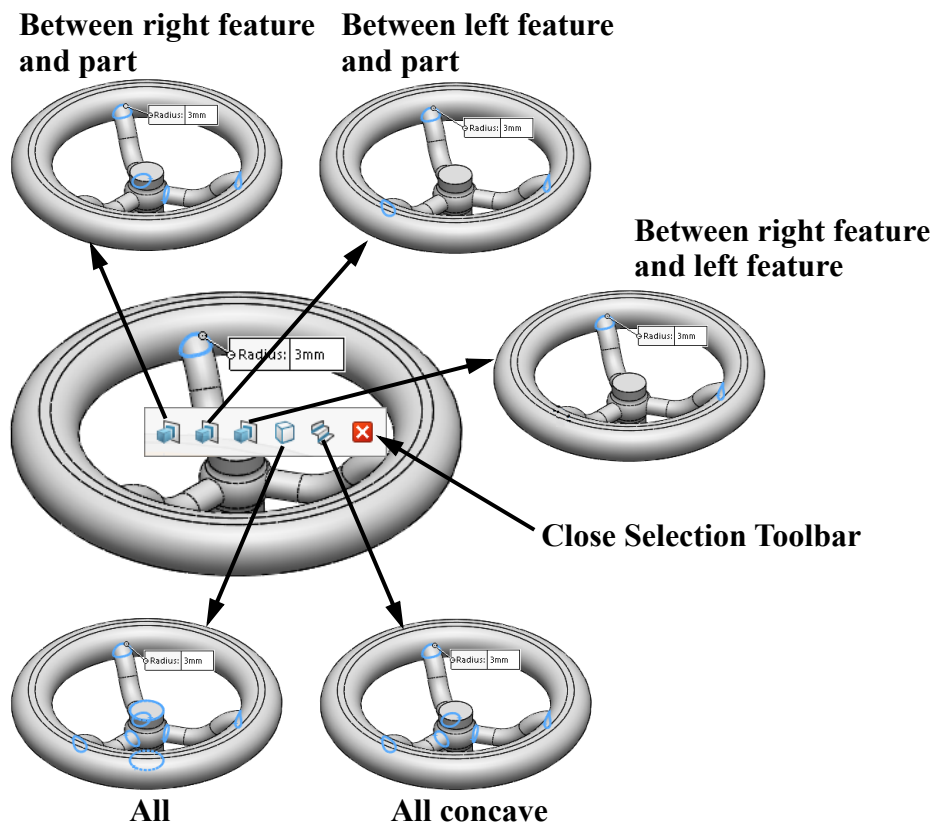

**Note** The number of available edge combinations, along with the naming and icons, will vary based on the selected edge. This toolbar can also be toggled off or ignored in favor of direct selections.

**Direct Selection** Similar results can be achieved through the direct selection of six edges or two faces. Selection of a face selects *all* edges of that face.

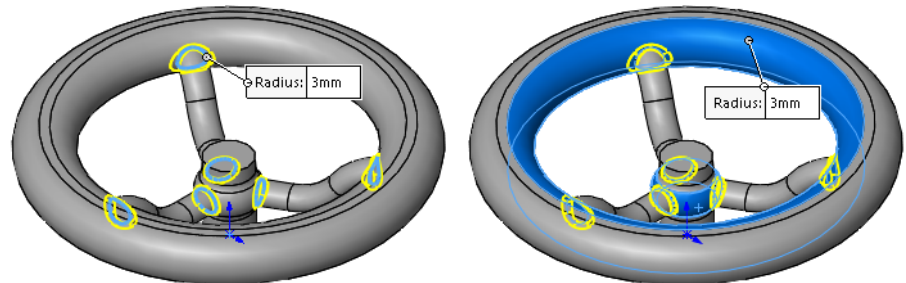

**Note** Face selections make the model better suited to withstand dimensional changes.

---

---

### 39 Add fillets.

Click **Fillet** and click **Show selection toolbar**.

Select an edge, and use the **All Concave** selection. Add **3mm** fillets to the edges as shown.

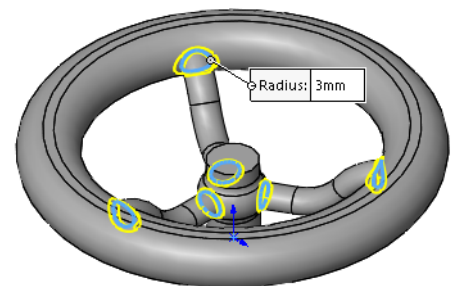

### Other Selection Options

You can also select edges by dragging a window or using keyboard shortcut.

- Drag the window from left to right, all the edges that are entirely inside the window are selected.
- Press **Ctrl+A** to select all the edges.

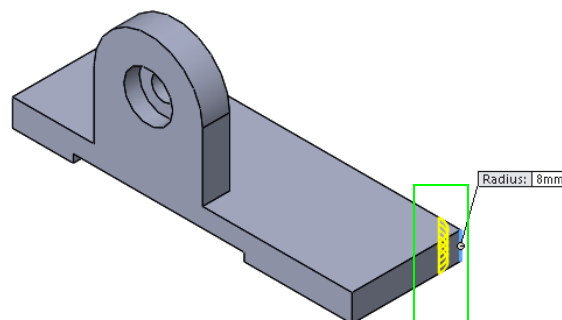

## Chamfers

Chamfers create a bevel feature on edges or vertices of a model. The shape can be defined by two distances or a distance and an angle. In many ways, chamfers are similar to fillets in that you select edges and/or faces in the same way.

### Where to Find It

- CommandManager: **Features** > **Fillet**  > **Chamfer** 
- Menu: **Insert, Features, Chamfer**
- Shortcut Menu: Right-click a face or edge and click **Chamfer** 

### 40 Chamfer.

Add a **Chamfer** feature using the top edge of the Hub feature. Select the **Chamfer Type Distance Distance** and the **Chamfer Method Asymmetric**.

Set the distances using the values shown.

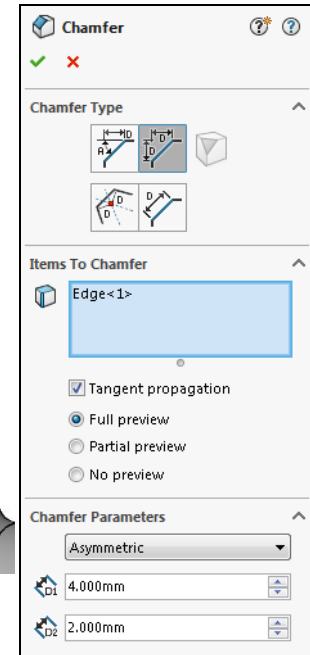
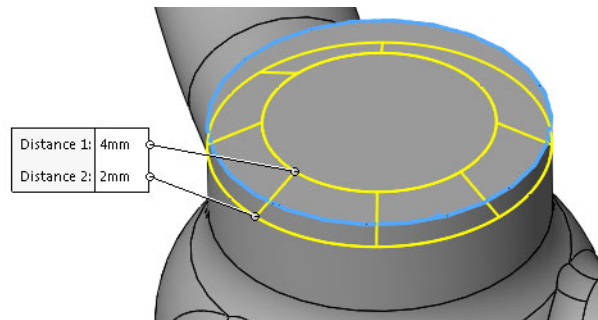

### Fillets to Chamfers

Another way to create a chamfer is by the conversion of an existing fillet. This can be done using the shortcut menu or while editing the feature.



### Where to Find It

- Shortcut Menu: Right-click a face or edge and click **Convert Fillet to Chamfer** 

### RealView Graphics

If you have a certified graphics accelerator, you may be able to use the **RealView Graphics** option. It provides high-quality, real time material shaders when available.

### Where to Find It

- Menu: **View, Display, RealView Graphics**
- Heads-up View Toolbar: **View Settings** , **RealView Graphics** 

**Note** If you do not have RealView Graphics, skip to step 45 on page 178.

**Tip** If **RealView Graphics** are not available, the icon will be grayed out.

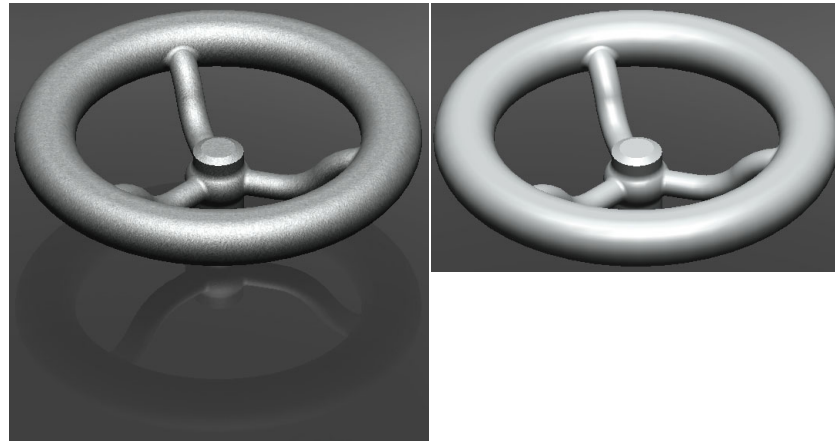

**RealView On**

**RealView Off**

**Appearances,  
Scenes and Decals**

The Appearances, Scenes and Decals tab of the Task Pane contains three main folders: Appearances(color), Scenes and Decals.

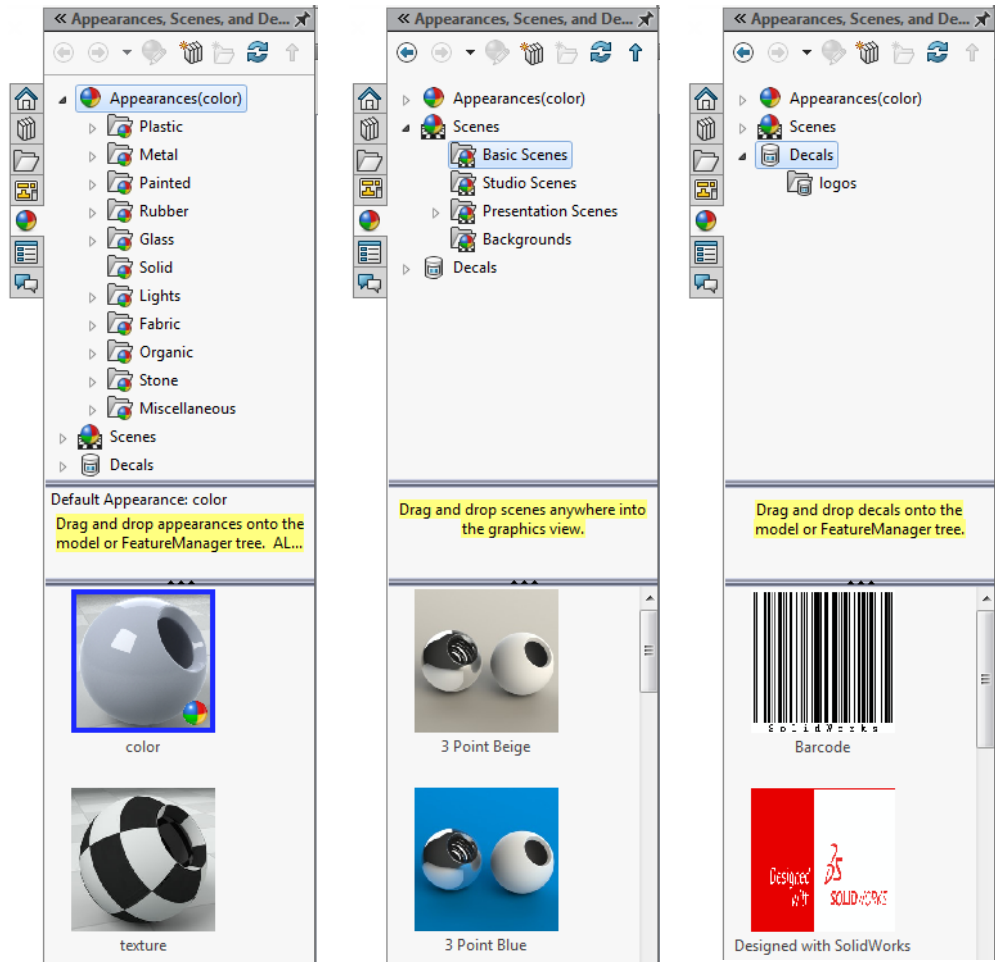

**41 RealView on.**

Click **RealView**  to toggle it on.

**42 Appearances and scenes.**

From the **Appearances**, **Painted**, **Powder Coat** folder, drag and drop **aluminum powdercoat** into the graphics window.

From the **Scenes**, **Basic Scenes** folder, drag and drop **Backdrop - Black with Fill Lights** into the graphics window.

**Tip**

The **Apply Scene**  flyout tool on the **Heads-up View** toolbar allows you to select and apply a scene from the list.

Another option is to click the icon to rotate through the list one at a time.

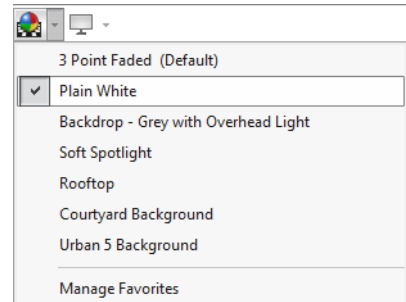
**Appearances**

Colors and textures are applied using **Appearances**. This menu has tabs for **Color/Image** and **Mapping**.

- **Color** is used to apply a color to the texture added from the **Appearance** folder.
- **Mapping** is used to change the mapping style of the texture added from the **Appearance** folder.

### 43 Color.

Click **Edit Appearance** and change the color using a **greyscale** color swatch and light gray or white. Click **OK**.

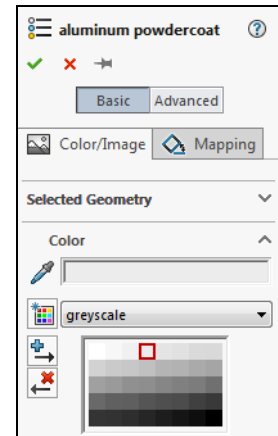

#### Note

Applying an appearance does not apply a material to the part. For applying materials, see *Edit Material* on page 178.

#### Tip

Click **View, Display, Ambient Occlusion** to add realism to the shaded model.

### 44 RealView off.

Click **RealView**  to toggle it off.

### 45 Save and close all files.

## Edit Material



The **Edit Material** dialog is used to add and edit the material associated with a part. The material is used for calculations that rely on material properties, including **Mass Properties** and **SimulationXpress**. The material can vary by configuration.

It's important to understand that applying an appearance is not the same as defining a material for the part. Appearances control the display of the model, while editing the material will apply material properties for the calculation of mass and density and often associated appearances.

#### Tip

Part templates (\*.prtdot) can include a predefined material.

#### Where to Find It

- Shortcut Menu: Right-click Material  and click **Edit Material** 

**1 Open HW\_Analysis.**

Open the existing part HW\_Analysis. This part has additional features needed for use in the analysis section of this lesson.

**2 Materials.**

Right-click **Edit Material**  and click **SOLIDWORKS Materials, Copper Alloys, Aluminum Bronze.**

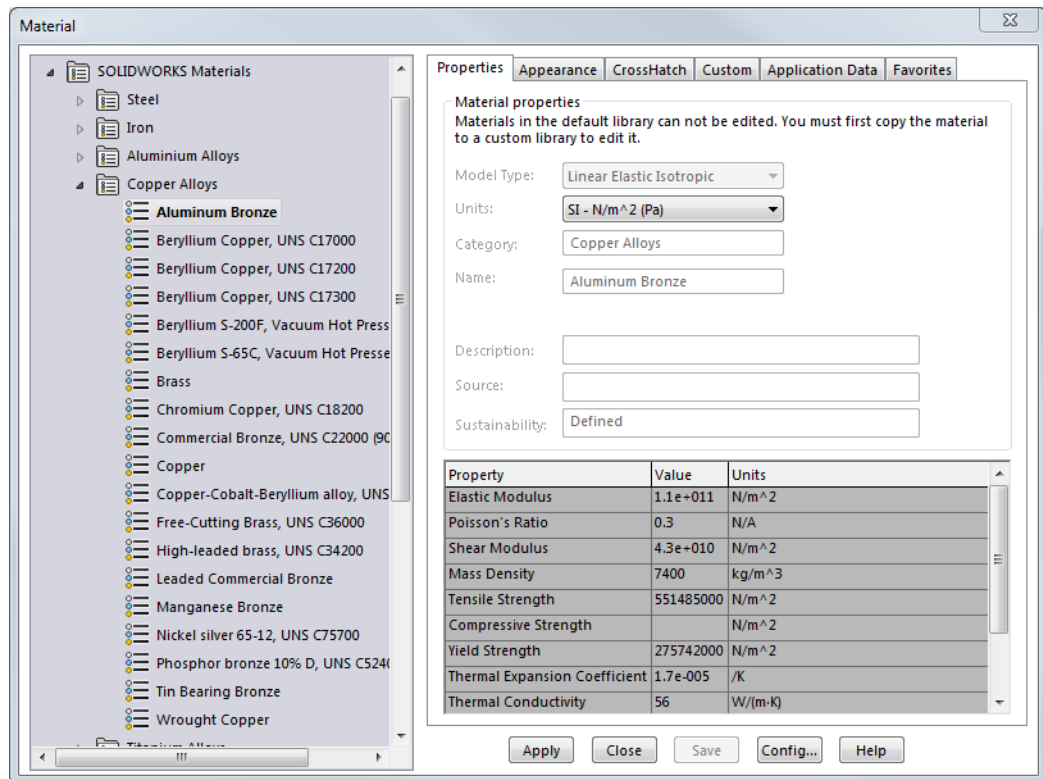

**Note**

The **Properties**, **Appearance** and **CrossHatch** are those assigned by the selected material.

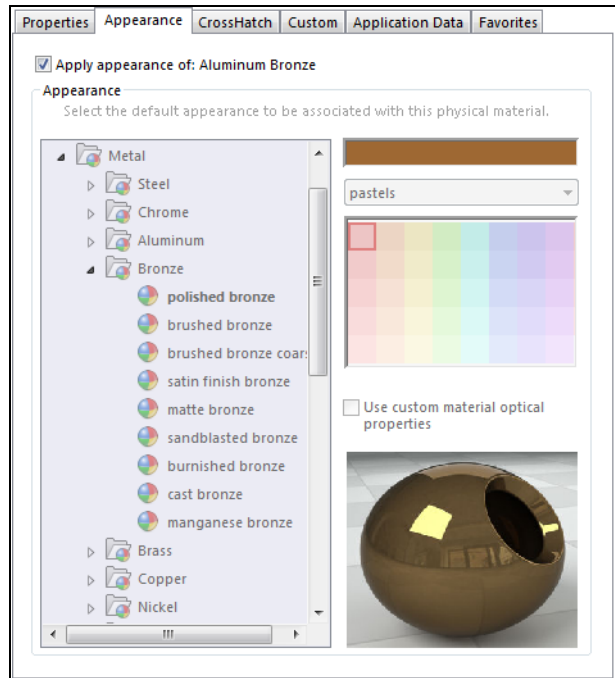

- 3 **Color.**  
Click **Apply** and **Close**.  
A change in material changes the color of the part. The material name is also updated in the FeatureManager design tree.

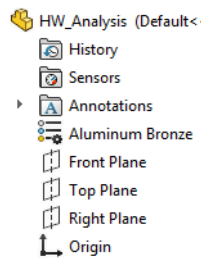
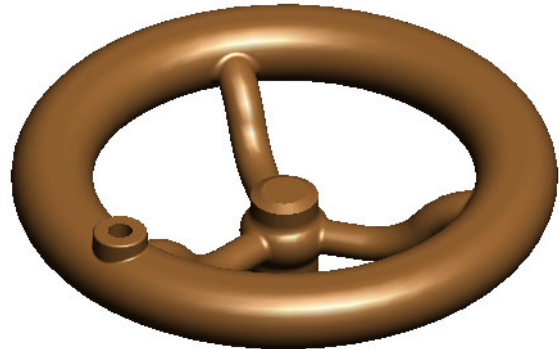

## Mass Properties

One of the benefits of working with a solid model is the ease with which you can perform engineering calculations such as computing mass, center of mass, and moments of inertia.

### Notes

- **Section Properties** can also be generated from a planar face or a sketch in a model. The sketch can be active or selected.
- You can add a **Center of Mass (COM)** feature. You can measure distances and add reference dimensions between the COM and other entities. You add a COM point in the **Mass Properties** dialog box or by clicking **Insert, Reference Geometry, Center of Mass**.

### Introducing: Mass Properties

**Mass Properties** is used to generate the mass properties of the entire solid. The properties include mass, volume and a temporary display of the principal axes.

### Where to Find It

- CommandManager: **Evaluate > Mass Properties** 
- Menu: **Tools, Evaluate, Mass Properties**

## 4 Mass properties.

Click **Mass Properties** . The **Density** of Aluminum Bronze is used. The results of the calculations are displayed in the dialog box.

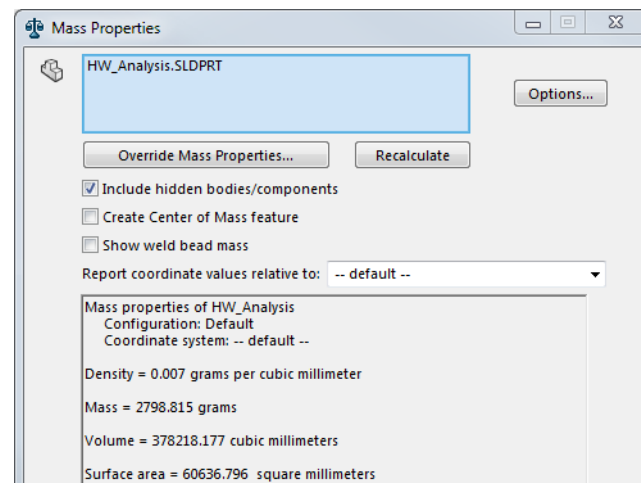

### Note

For those parts that do not possess an accurate physical description, you can click **Override Mass Properties**. You can override mass, center of mass, and the moments of inertia. This is helpful when you use simplified models of purchased components.

To change the units, click **Options**, click **Use custom settings**, and set the units. There are other options you can set including the density and the accuracy level of the calculations.

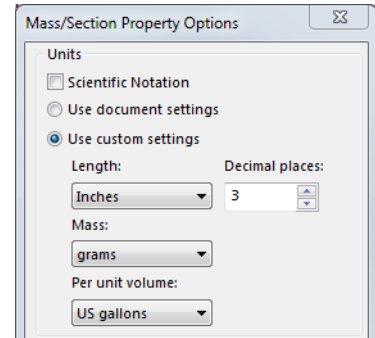

---

## Mass Properties as Custom Properties

Components of the **Mass Properties** of a part can be carried with the part as a **Custom Property**. This information can be extracted by a Bill of Materials report.

## File Properties

File properties are details about Windows based files that help identify it – for example, a descriptive title, the author name, the subject, and keywords that identify topics or other important information in the file. Document properties can be used to display information about a file or to help organize files so that they can be found easily. You can search for documents based on document properties.

There are file properties unique to SOLIDWORKS that are more suited to engineering than the default properties. Additional properties can be added based on the user's needs.

## Metadata

File properties and attributes are sometimes referred to as Metadata.

## Classes of File Properties

File properties can be grouped into several classes.

### ■ Automatic

Automatic properties are maintained by the application that created the property. These include properties such as the date the file was created, last modified and file size.

### ■ Preset

Preset properties already exist, but the user must fill in the text value. The preset file properties used in SOLIDWORKS are stored in the file Property.txt. This file may be edited to add or remove preset properties.

### ■ Custom

Custom properties are defined by the user and apply to the entire document.

### ■ Configuration specific

Configuration specific properties apply only to a specific configuration.

- **SOLIDWORKS custom properties**

There are several custom properties that can be automatically updated by SOLIDWORKS. These include the part's mass and material.

### Where to Find It

- Menu: **File, Properties**

### Creating File Properties

File properties can be created directly in the file, or they can be created by other procedures.

- **Direct method**

File properties are added directly to the file by the user.

- **Design tables**

Design tables can create custom properties using a column header **\$PRP@property** where **property** is the name of the property to be created and populated with the information created in the design table.

- **Custom Properties Tab**

Form templates for adding properties can be created using the **SOLIDWORKS Property Tab Builder**. These forms can then be accessed from the Task Pane using the **Custom Properties** tab.

- **SOLIDWORKS PDM applications**

SOLIDWORKS PDM applications will add several custom properties to files checked into the vault. These include: number, status, description, project and revision. SOLIDWORKS PDM applications can also be configured to add additional properties defined by the Vault Administrator.

### Uses of File Properties

File properties can be used for several operations.

- **Parts, assemblies and drawings**

File properties can be used to create parametric notes. Annotations linked to file properties will update as the properties change.

- **Assemblies**

**Advanced Selection** and **Advanced Show/Hide** can select components based on specific file properties. Specific procedures are found in the training course *Assembly Modeling*.

- **Drawings**

File properties can be used to fill in data in the title block, BOM, revision blocks and annotations. Specific procedures are found in the training course *SOLIDWORKS Drawings*.

To communicate the description of this model and its weight, we'll add some custom properties to the file.

### 5 File properties.

Click **File Properties**  and click the **Custom** tab. Activate the **Property Name** cell in the first row of the dialog. Use the arrow at the right of the cell to choose **Description** from the preset properties. In the **Value/Text Expression** cell, type Handwheel for Globe Valve as the description.

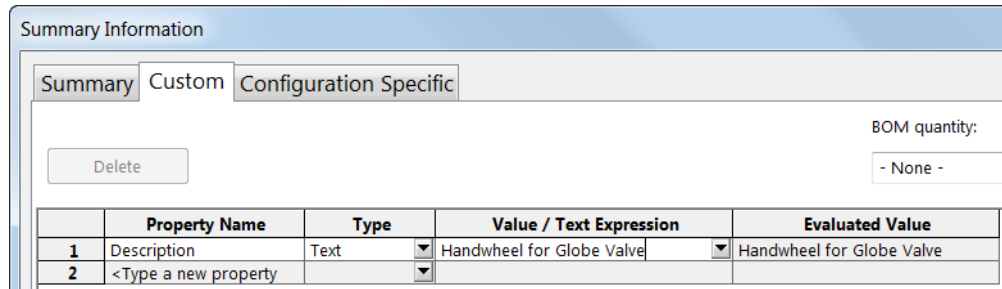

### 6 New custom property.

Activate the **Property Name** cell and type in the **mass**. In the **Value/Text Expression** cell, choose **Mass** from the preset properties. The **Evaluated Value** cell shows the current mass and how it would appear in a table or drawing title block. Close the dialog.

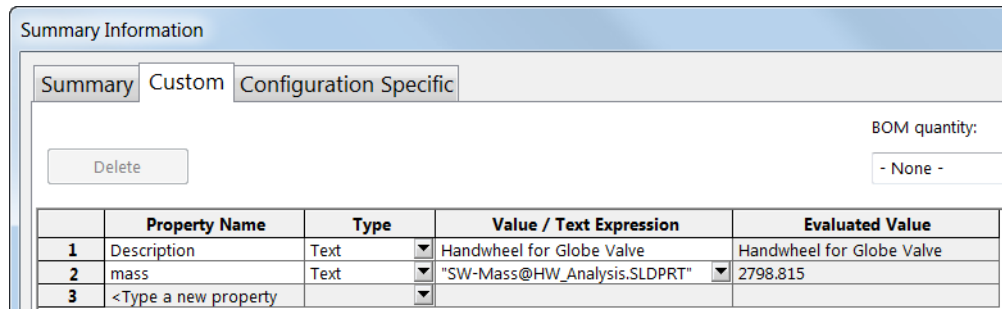

**Note**

The Configuration Specific tab can also be used. This would allow the property to vary by configuration.

## SOLIDWORKS Simulation- Xpress

With the solid 3D geometry of the hand wheel and the material defined, we have all the information we need to simulate how this model would react to stresses applied to the part. We'll use the SimulationXpress tool to do this.

SOLIDWORKS SimulationXpress is a *first pass* stress analysis tool for SOLIDWORKS users. It helps you judge whether your part will withstand the loading it will receive under real-world conditions. SOLIDWORKS SimulationXpress is a subset of the SOLIDWORKS Simulation product.

### Product Code

In order to run SOLIDWORKS SimulationXpress, a product code is required. The product can be generated from your SOLIDWORKS serial number. See the **Enable SimulationXpress** dialog on start up.

### Overview

SOLIDWORKS SimulationXpress uses a wizard to provide an easy to use, step-by-step method of performing design analysis. The wizard requires several pieces of information in order to analyze the part: *fixtures*, *loads* and *materials*. This information represents the part as it is used. For example, consider what happens when you turn the handwheel. The hub is attached to something that resists turning. This is represented by a *fixture*. Fixtures are sometime called *constraints*. A force is applied to the hole in the rim as you attempt to turn the handwheel. This is a *load*. What happens to the spokes? Do they bend? Will they break? This depends on the strength of the material the handwheel is made of, the physical size and shape of the spokes, and the size of the load.

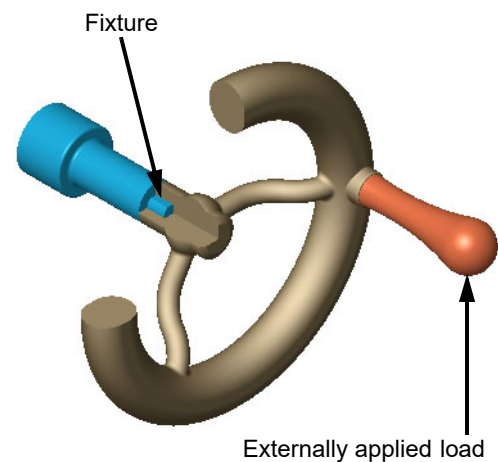

### Mesh

In order to analyze the model, SOLIDWORKS SimulationXpress automatically *meshes* the model, breaking it up into smaller, easier-to-analyze pieces. These pieces are called *elements*.

Although you never see the elements, you can set the coarseness of the mesh prior to the analysis.

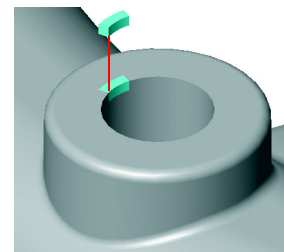

## Using SOLIDWORKS Simulation- Xpress

**SOLIDWORKS SimulationXpress** walks you through the steps of analysis, from **Options** to **Optimize**. The steps are:

- **Options**  
Setup the type of units that are commonly used for materials, loads and results.
- **Fixtures**  
Select faces of the part that remain in place (fixed) during the analysis.
- **Loads**  
Add external loads such as forces and pressures to induce stress and to deform the part.
- **Material**  
Choose a material for the part from the standard library or input your own.
- **Run**  
Run the analysis, optionally setting the coarseness of the mesh used.
- **Results**  
View the results of the analysis: Factor of Safety (FOS), Stress and Deformations. This is sometimes called *postprocessing*.
- **Optimize**  
Optimize a result quantity using a selected dimension.

### Where to Find It

- CommandManager: **Evaluate >**  
**SimulationXpress Analysis Wizard** 
- Menu: **Tools, Xpress Products, SimulationXpress**

### 1 Start SimulationXpress.

Click **SimulationXpress** . The analysis wizard appears in the Task Pane.

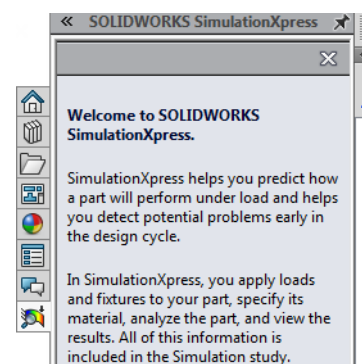

### Note

The first time that the **SimulationXpress Analysis Wizard** is run, it will require a **SimulationXpress Product Code**. Follow the instructions on the dialog to receive a code.

## The SimulationXpress Interface

The **SOLIDWORKS SimulationXpress** interface begins in the Task Pane, where the checklist of sequential tasks appears under the SOLIDWORKS SimulationXpress  tab. Selection options and the SimulationXpressStudy tree appear in the PropertyManager.

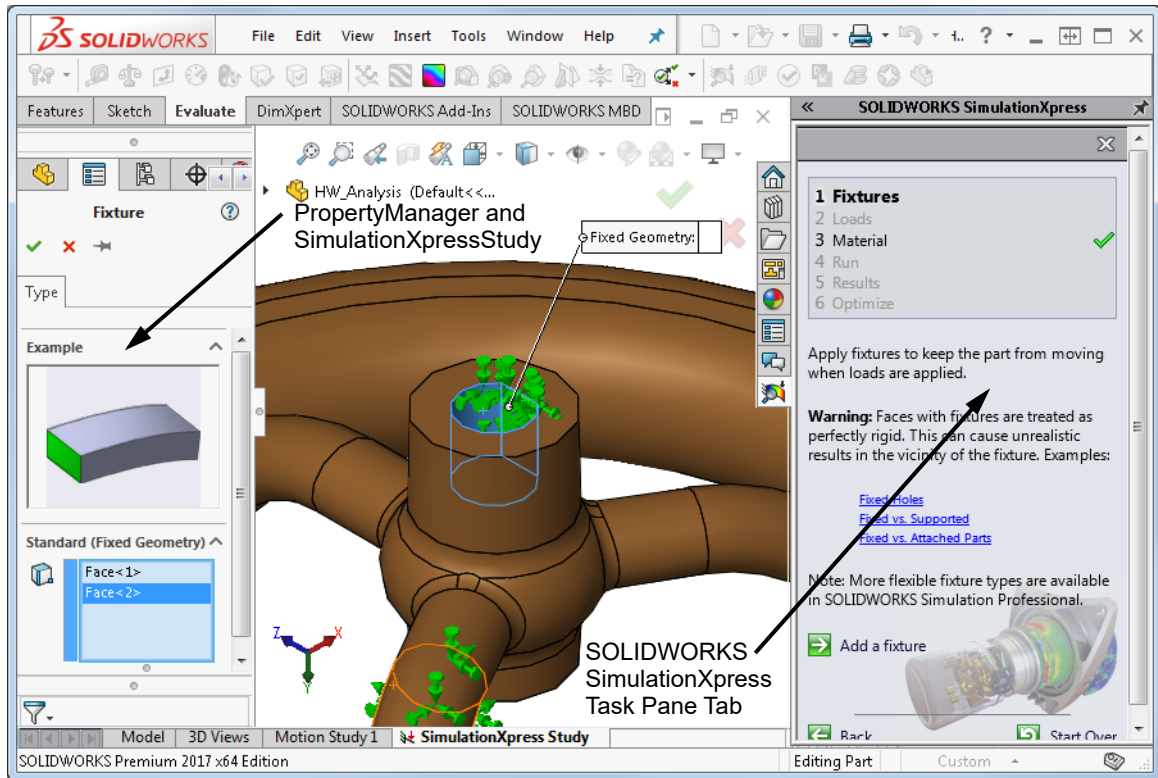

## Options

The **Options** dialog contains settings for the **System of units** and **Results location**.

### 2 Click Options.

Set the units to **SI** and use the default **Results location**. Click **Show annotation for maximum and minimum in the result plots**.

Click **OK** and click  **Next**.

### Phase 1: Fixtures

Fixtures are used to “fix” faces of the model that should not move during the analysis. You must restrain at least one face of the part to avoid analysis failure due to rigid body motion. As you complete each phase in the wizard, a green check mark ✓ is added to the list.

#### 3 Fixtures page.

Click ➔ **Add a fixture.**

#### Tip

Move the cursor over the blue hyperlinks (such as [Fixed Holes](#)) for examples.

#### 4 Face selection.

Select the cylindrical face and the flat face that form the D-shaped hole.

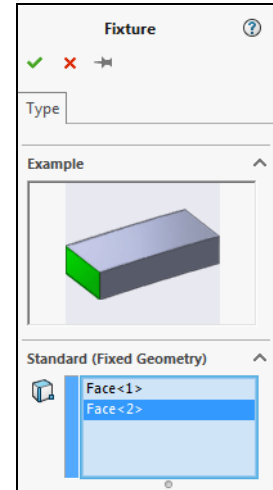
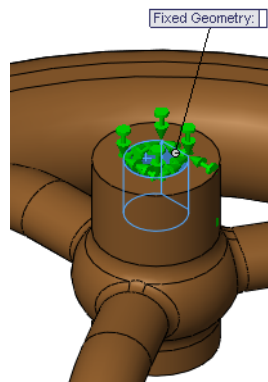

Click **OK** and click **Next**.

### Simulation Study

A **SimulationXpress Study** is being constructed as the wizard steps are completed. The FeatureManager design tree is split and the lower portion contains the SimulationXpressStudy tree.

Eventually it will include fixtures, loads, mesh and the results of the analysis.

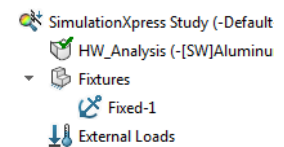

**Phase 2: Loads**

The **Loads** page is used to add external forces and pressures to faces of the part. **Force** implies a total force, for example 200 lbs, applied to a face in a specific direction. **Pressure** implies that the force is evenly distributed on the face, for example, 300 psi, and is applied normal to the face.

**Note**

The specified force value is applied to *each* face. For example, if you select 3 faces and specify a 50 lb. force, SimulationXpress applies a total force of 150 lbs. or 50 lbs. on each face.

**5 Loads page.**

In this example, we will use a **Force** type load. Click  **Add a force**.

**6 Select the face.**

Select the cylindrical face as shown. Click **Selected direction** and click the Right plane.

Set the **Force** to **3000**.

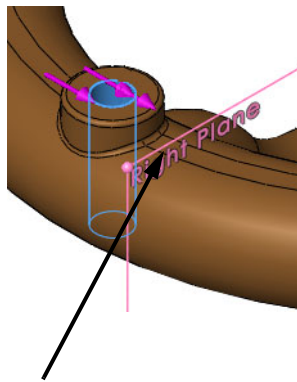

Click **OK** and click **Next**.

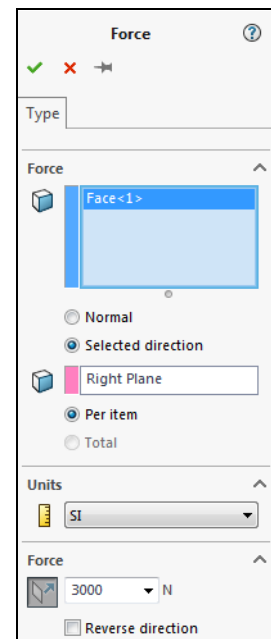
**Phase 3: Material**

The next phase is selecting the **Material**. You can choose from libraries of standard materials or add your own.

**7 Material page.**

The current material, selected within SOLIDWORKS, is **Aluminum Bronze** from the **Copper Alloys** list.

To change the material, click **3 Material**, click **Change material** and select from the list.

This is the same list that appears when using **Edit Material**.

Click **Next** to keep Aluminum Bronze as the material.

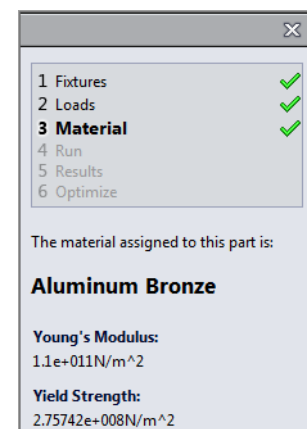

## Phase 4: Run

SimulationXpress prepares the model for analysis, creates the mesh and calculates displacements, strains, and stresses.

### 8 Run page.

The required information has been provided and the analyzer is ready.

Click  **Run Simulation**.

## Phase 5: Results

The **Results** page is used to display the results of analysis. The full SimulationXpressStudy tree is shown in the split FeatureManager design tree. This includes all the input and output of the study.

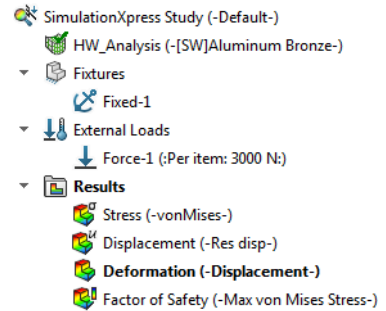

## Tip

Double-click a result feature (such as Stress (-vonMises-)) to view it.

### 9 Results.

A preview of the deformation plot appears on the screen. The deformation is scaled to make it easier to visualize.

If the part is deforming as expected you can view the other result plots of the study. Click  **Yes, continue** to see the next result.

## Factor of Safety

SimulationXpress uses the maximum von Mises stress criterion to calculate the factor of safety distribution. This criterion states that a ductile material starts to yield when the equivalent stress (von Mises stress) reaches the yield strength of the material. The yield strength (SIGYLD) is defined as a material property. SimulationXpress calculates the factor of safety at a point by dividing the yield strength by the equivalent stress at that point.

At any location, a factor of safety that is:

- Less than 1.0 indicates that the material at that location has yielded and that the design is not safe.
- Equal to 1.0 indicates that the material at that location has just started to yield.
- Greater than 1.0 indicates that the material at that location has not yielded.

**10 Factor of safety.**

The **FOS** has areas that are less than **1**. This indicates that areas of the part are overstressed and will fail.

Red areas indicate where the factor of safety is less than one. The Task Pane also shows the actual factor of safety value.

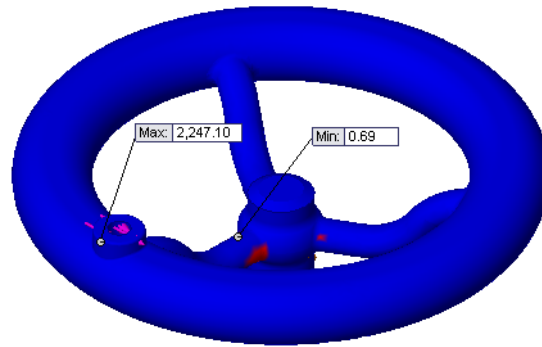

Click **Done viewing results** and **Next**.

**Phase 6: Optimize**

The Optimize tab can be used to bring **Factor of Safety**, **Max Stress** or **Maximum Displacement** values to acceptable levels by iterating the value of a dimension. The optimization is performed within set numeric boundaries with the above constraints.

**11 Optimize the model.**

Click **Yes** for **Would you like to optimize your model?** and **Next**.

**12 Value to change.**

Select the **14mm** dimension (major axis of the ellipse) as the dimension to change.

Click **OK**.

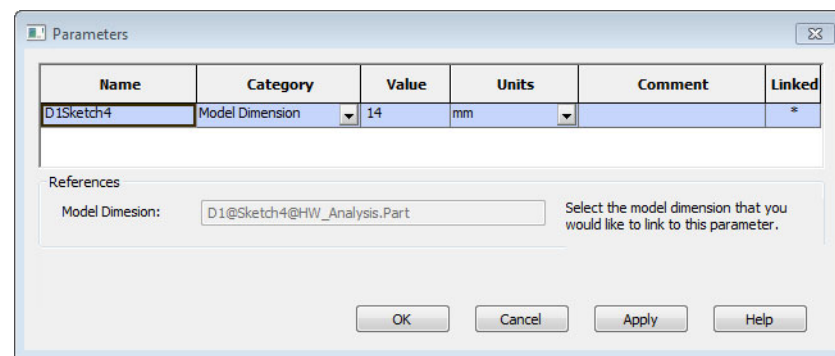
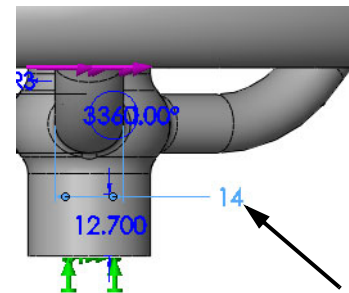

### 13 Variables and constraints.

Set the **Min** and **Max Variable** values to **18mm** and **22mm** as shown. For **Constraints**, select **Factor of Safety** and set it to a minimum of **1**.

Click **Run**.

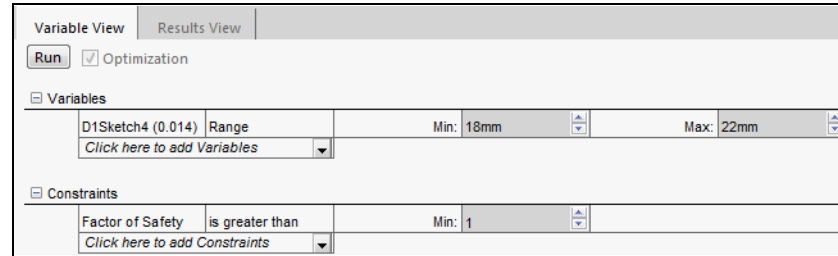

### 14 Results.

After several iterations, the optimization is complete. Click the **Results view** tab. The resulting changes meet the FOS target with only a small increase in weight.

	Initial	Optimal
D1Sketch4 (0.0195339)	14mm	19.53389mm
Factor of Safety	0.672752	1.012301
Mass	2.79681 kg	2.87243 kg

### 15 Optimization results.

Click the **Optimal Value** option and click **Next**.

Click **4 Run** and **Run Simulation**.

## Updating the Model

Changes performed in SOLIDWORKS or during optimization are detected by SimulationXpress. Changes can be made to the model, materials, fixtures or loads. The existing analysis can be re-analyzed to show the newest results.

### 16 Save data.

Click **Close** in the SOLIDWORKS SimulationXpress window and **Yes** to save the data.

### 17 Change model.

The optimization process changed the selected dimension value. Click the **Model** tab on the bottom of the graphics window and change that dimension to the rounded value **20mm** (in Sketch4 under the Spoke feature) and rebuild.

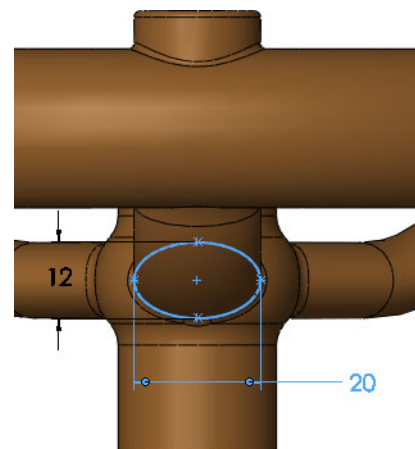

**18 Retrieve data.**

Start SimulationXpress again and run the simulation again to update the results.

**19 Save and close.**

Click **Close** in the SOLIDWORKS SimulationXpress window and **Yes** to save the data.



**20 Save and close the part.**

**Results, Reports and eDrawings**

The following are some examples of the different types of output that are available with an analysis. They include results, reports and eDrawing files.

**Note**

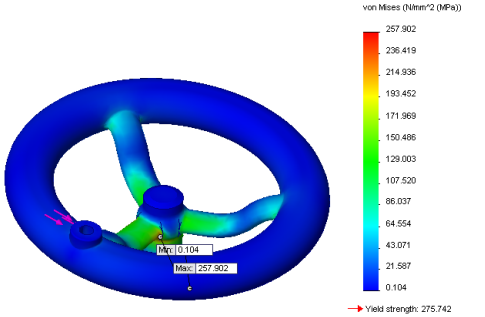
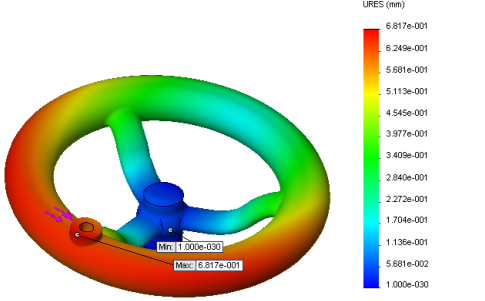
Some of the displays are exaggerated by a deformation scale.

Type	Display
<p><b>Stress (-vonMises-)</b></p>	
<p><b>Displacement (-Res disp-)</b></p>	
<p><b>Deformation (-Displacement-)</b></p>	

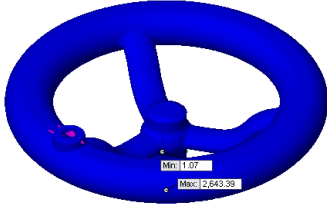
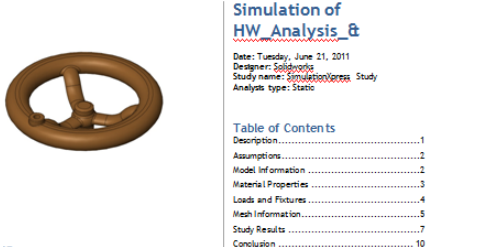
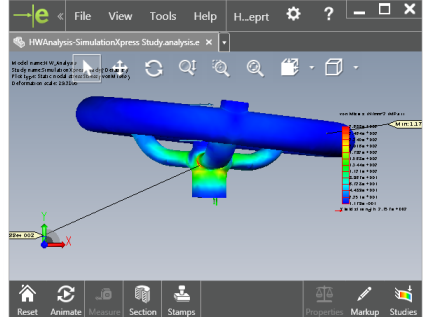
Type	Display
<p style="text-align: center;"><b>Factor of Safety (-Max von Mises Stress-)</b></p>	
<p style="text-align: center;"><b>Word Report</b></p>	
<p style="text-align: center;"><b>eDrawings File</b></p>	

**Exercise 19:  
Flange**

Create this part using the dimensions provided. Use relations wisely to maintain the design intent.

This lab uses the following skills:

- *Revolved Features* on page 159

Units: **millimeters**

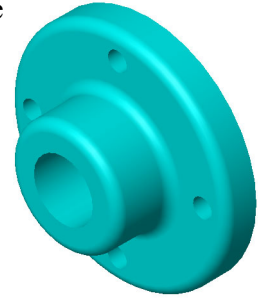
**Design Intent**

The design intent for this part is as follows:

1. Holes in the pattern are equally spaced.
2. Holes are equal diameter.
3. All fillets are equal and are **R6mm**.

Note that construction circles can be created using the **Properties** of a circle.

**Dimensioned Views**

Use the following graphics with the description of the design intent to create the part.

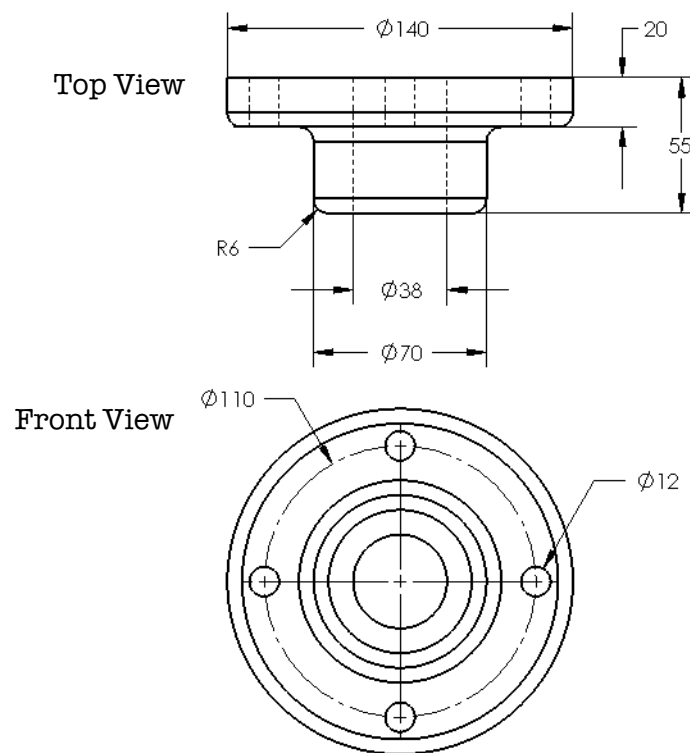

## Exercise 20: Wheel

Create this part using the dimensions provided. Use relations wisely to maintain the design intent.

This lab uses the following skills:

- *Revolved Features* on page 159

Units: **millimeters**

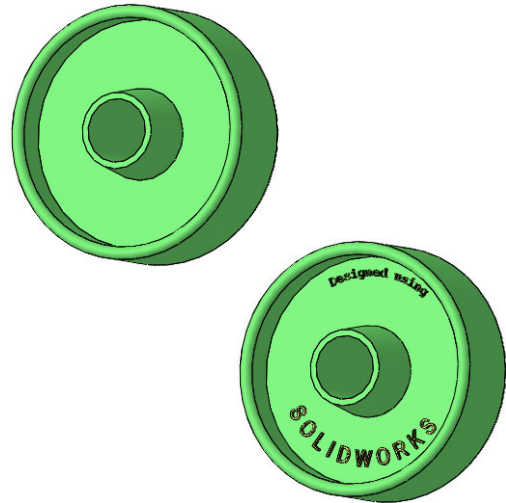

### Design Intent

The design intent for this part is as follows:

1. Part is symmetrical about the axis of the hub.
2. Hub has draft.

### Dimensioned Views

Use the following graphics with the description of the design intent to create the part.

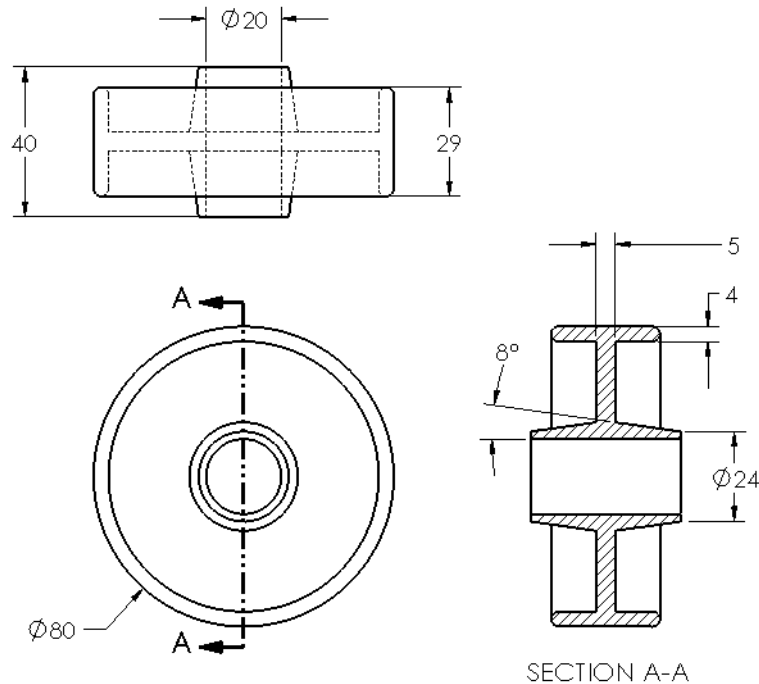

Front and Top views, and Section A-A from Front view.



**Optional: Text in a Sketch**

Text can be added to a sketch and extruded to form a cut or a boss. The text can be positioned freely, located using dimensions or geometric relations, or made to follow sketch geometry or model edges.

**Where to Find It**

- CommandManager: **Sketch > Text** 
- Menu: **Tools, Sketch Entities, Text**
- Shortcut Menu: Right-click in the graphics area and click **Sketch Entities, Text** 

**Tip****1 Construction geometry.**

Sketch on the front face and add construction lines and arcs as shown.

Use **Symmetric** relationships between the endpoints of the arcs and the vertical centerline.

**2 Text on a curve.**

Create two pieces of text, one attached to each arc. They have the following properties:

- **Text: Designed using**
- **Font: Courier New 11pt**
- **Alignment: Center Align**
- **Width Factor: 100%**
- **Spacing: 100%**
  
- **Text: SOLIDWORKS**
- **Font: Arial 20pt**
- **Alignment: Full Justify**
- **Width Factor: 100%**
- **Spacing: not applicable when using Full Justify**

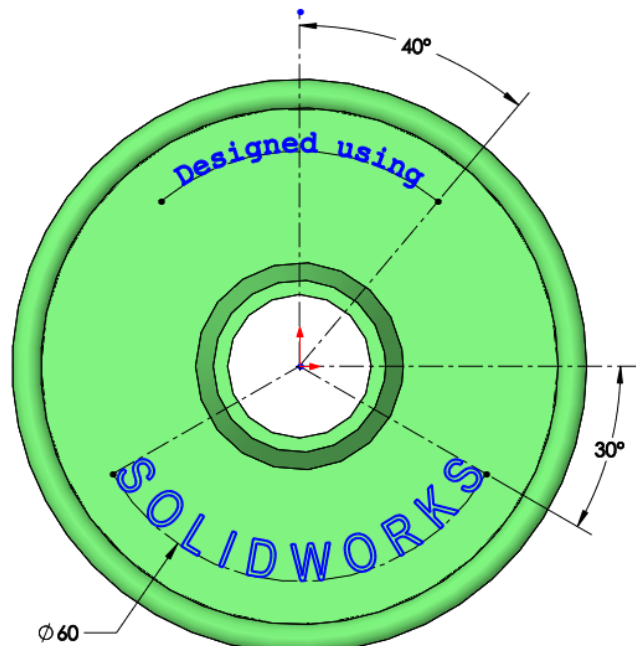

- 3 Extrude.**  
Extrude a boss with a **Depth** of **1mm** and **Draft** of **1°**.

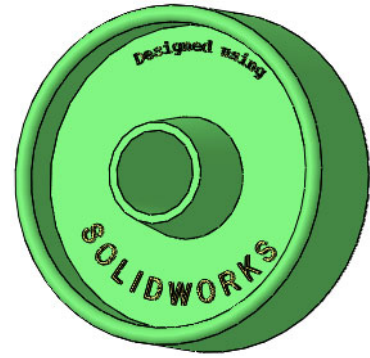

**Note** Extruding text can be time consuming.

- 4 Save the part and close it.**
-

**Exercise 21:  
Guide**

Create this part using the information and dimensions provided. This lab reinforces the following skills:

- *Introducing: Slots* on page 165

Units: **millimeters**

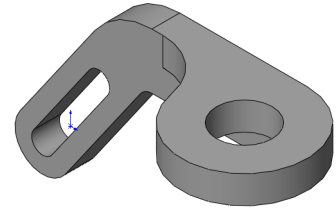
**Procedure**

Create a new mm part and name it Guide. Create the geometry as shown in the following steps.

**Note**

These images show the sketch relations (**View, Sketch Relations**) for clarity.

**1 Lines and fillet.**

Open a sketch on the Front plane. Create the sketch lines, a sketch fillet and an angular dimension as shown.

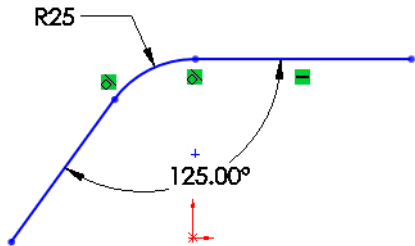
**2 Offset.**

Use offset entities to create the **20mm** offset as shown.

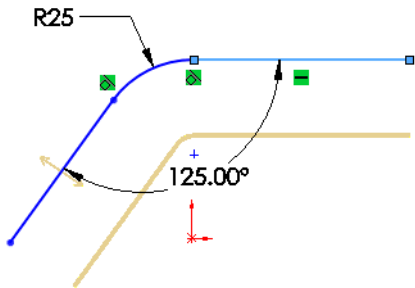
**3 Close ends.**

Close the ends using a tangent arc and a line as shown.

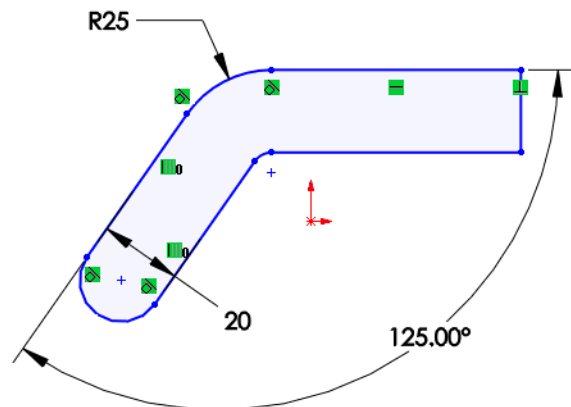

**4 Drag to origin.**

Drag the centerpoint of the arc to the Origin and drop it. This creates a Coincident relation.

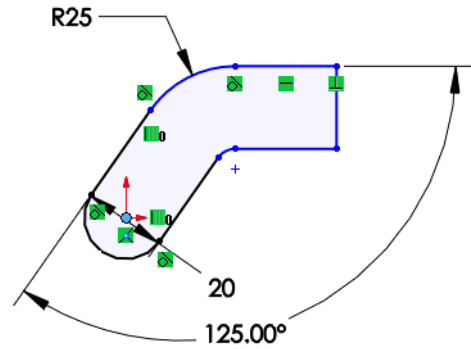

**5 Virtual Sharp.**

A Virtual Sharp is used to represent an imaginary corner where lines would meet.

Add a virtual sharp by selecting the two lines as shown and clicking **Point** .

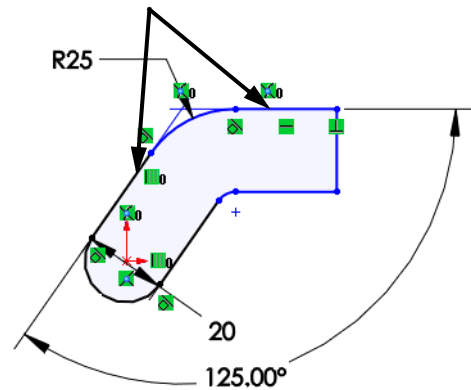

**6 Fully defined.**

Complete the sketch by adding dimensions as shown.

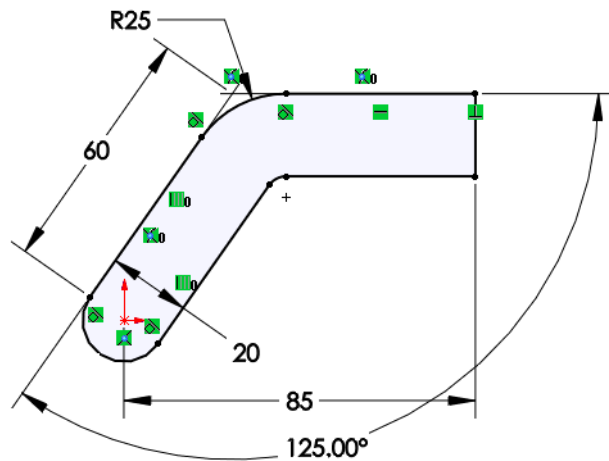

**7 Extrude.**

Extrude the sketch 10mm.

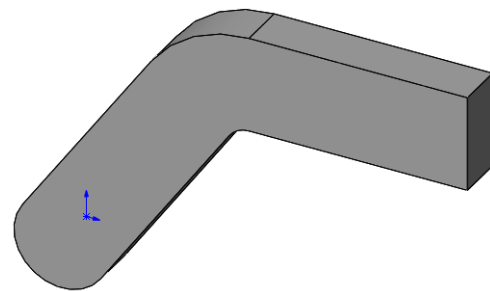

**8 Circle and boss.**

Add a circle to a new sketch on the top face of the model. Use **Tangent** and **Coincident** relations to relate the circle to the geometry. Fully define and extrude the sketch **10mm** as shown.

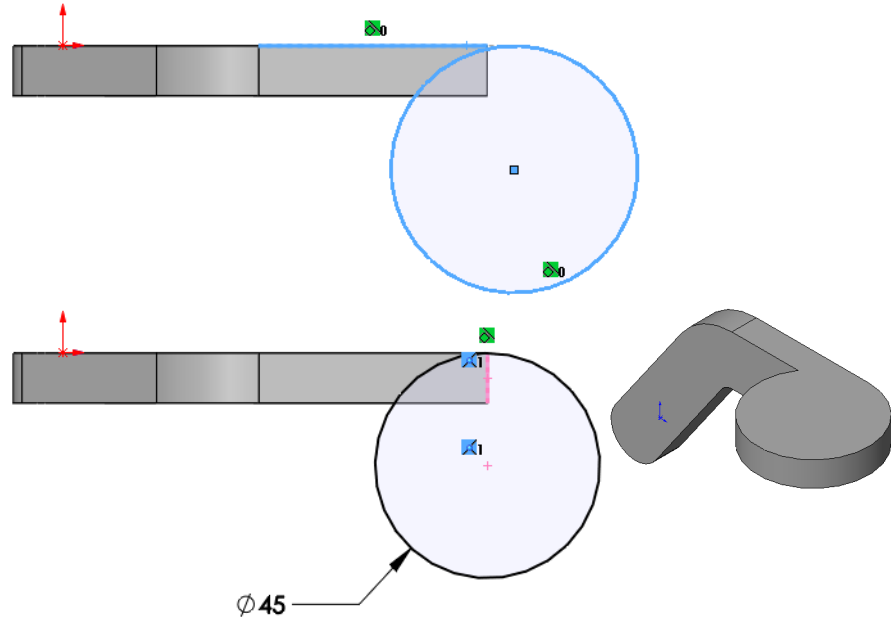
**9 Fillet.**

Add a fillet **R20mm** as shown.

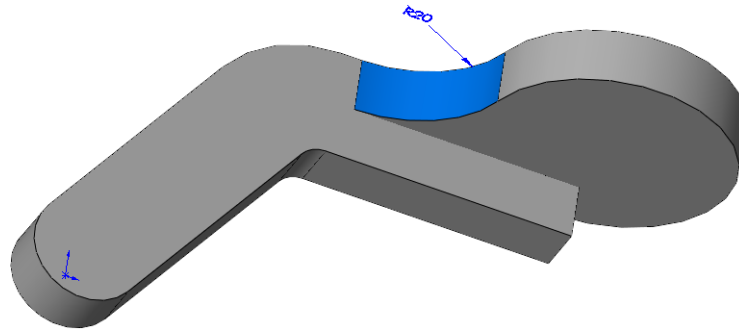

**10 Slot.**

Use **Straight Slot** with the options **Overall Length** and **Add Dimensions** to create the geometry shown below. Create a through all cut with the sketch geometry.

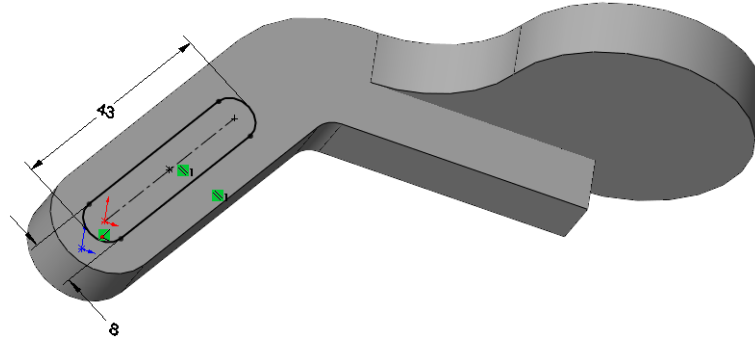

**Tip**

The slot sketch should be fully defined. It may require a **Parallel** relation.

**11 Hole.**

Add a **20mm** through all hole to complete the part.

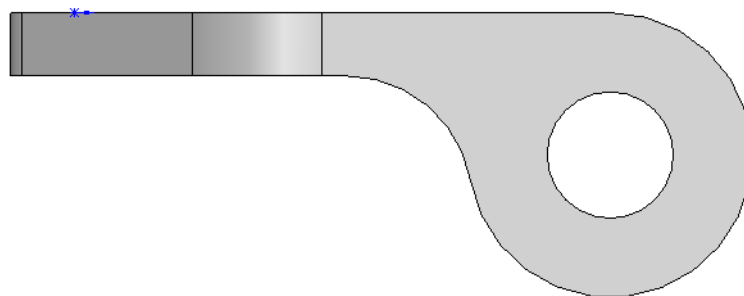

**12 Save and close.**

**Exercise 22:**  
**Ellipse**

Use an ellipse to create the part.  
This lab reinforces the following skills:

- *Introducing: Insert Ellipse* on page 171

Units: **millimeters**

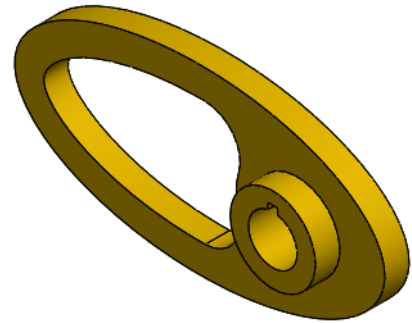

**Procedure**

Create a new mm part. Create the geometry as shown in the following drawing.

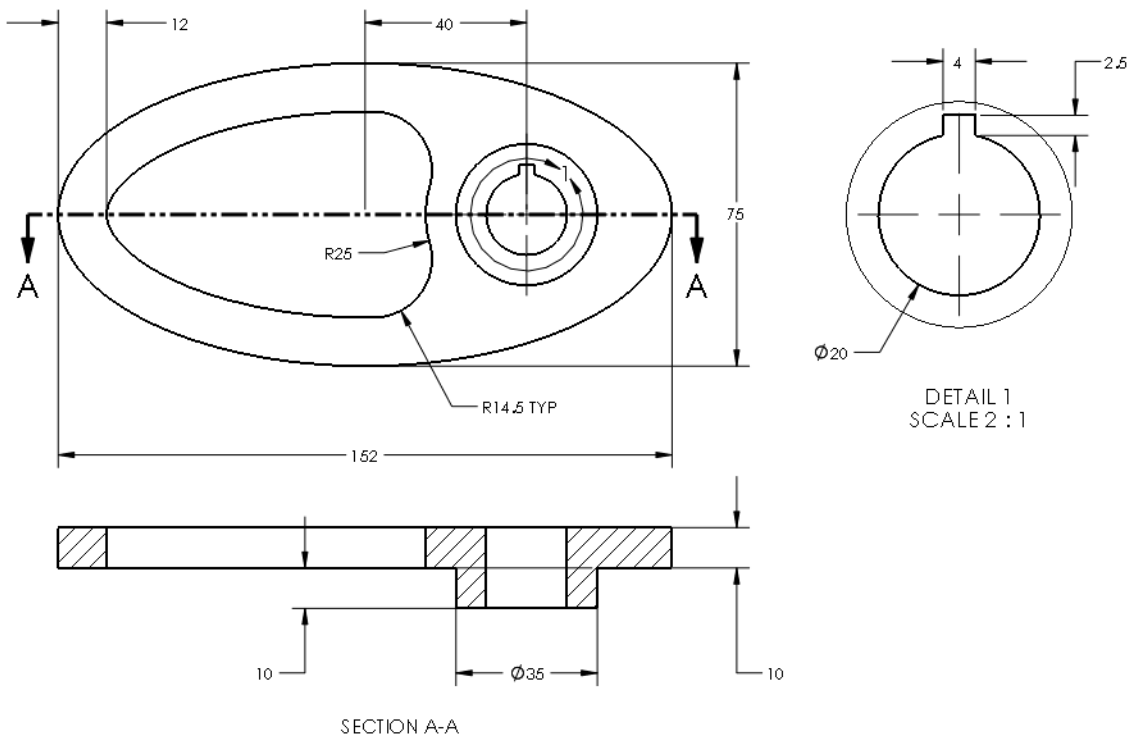

### Exercise 23: Sweeps

Create these three parts using swept features. These require a path and a section or a path and the **Circular Profile** option.

This lab uses the following skills:

- *Introducing: Sweep* on page 172

Units: **millimeters**

#### Slide Stop

The Slide Stop uses a path that describes the centerline of the sweep.

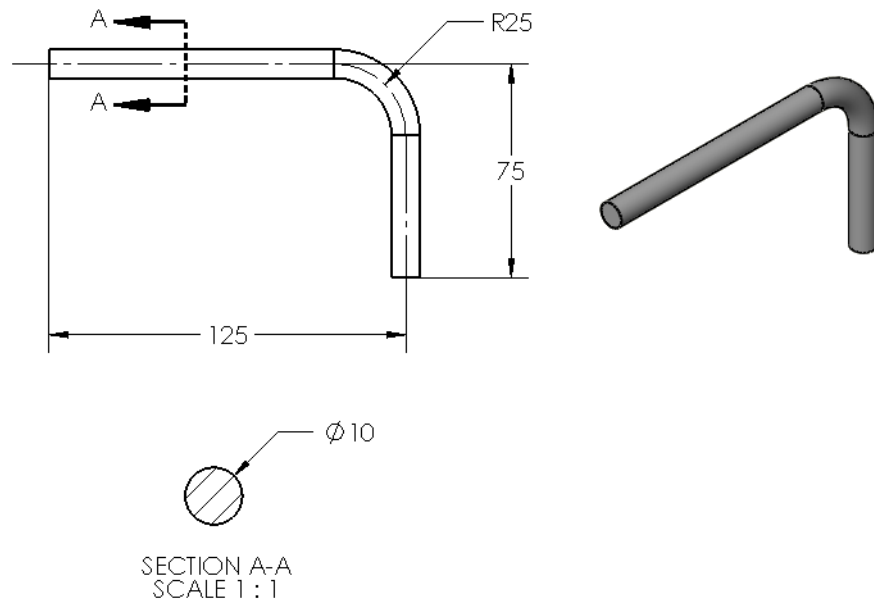

#### Cotter Pin

The Cotter Pin uses a path that describes the inner edge of the sweep.

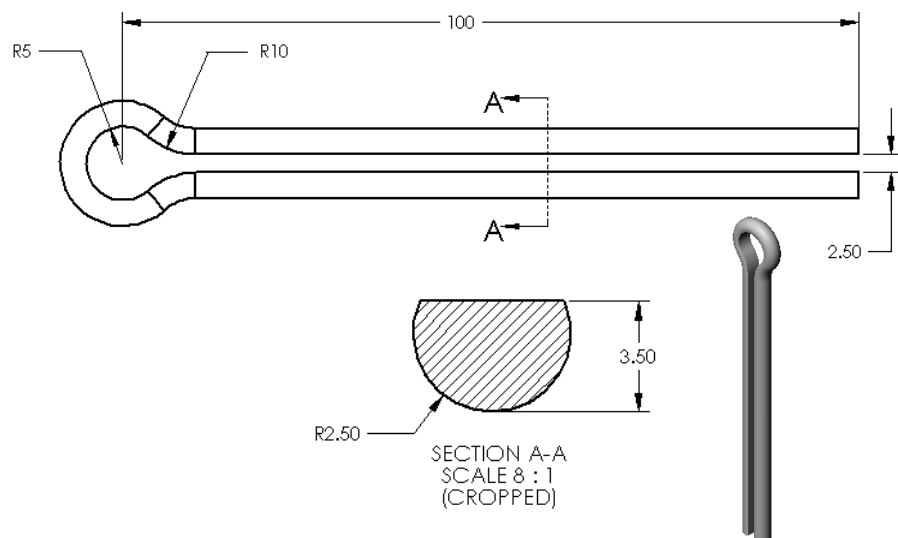

**Paper Clip**

The Paper Clip is defined by a path that describes the centerline of the sweep. Use a path and a section or a path and the **Circular Profile** option.

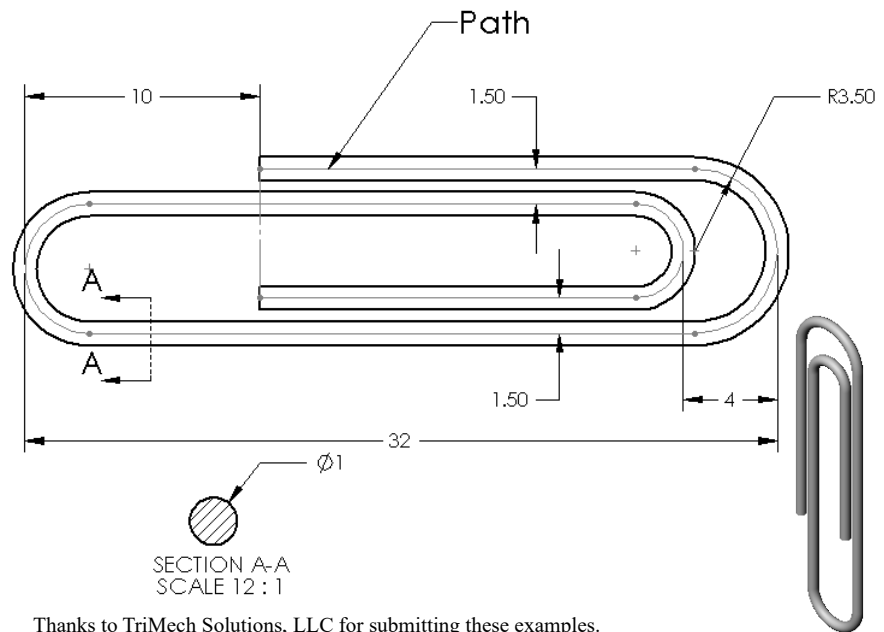

Thanks to TriMech Solutions, LLC for submitting these examples.

**Mitered Sweep**

The Mitered Sweep is defined by a path that describes the outer edge of the sweep.

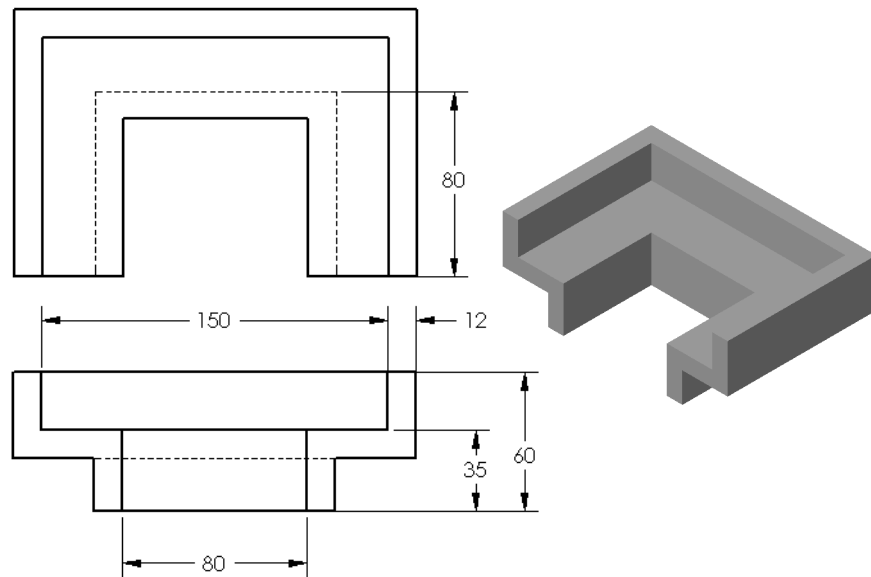

## Exercise 24: Simulation- Xpress

Perform a first pass stress analysis on an existing part.

This lab uses the following SimulationXpress skills:

- *Phase 1: Fixtures* on page 188
- *Phase 2: Loads* on page 189
- *Phase 3: Material* on page 189
- *Phase 4: Run* on page 190
- *Phase 5: Results* on page 190

Units: **millimeters**

### 1 Open Pump Cover.

This part represents a cover that will be filled with oil under high pressure.

Start the SimulationXpress wizard.

### 2 Set the options.

Click **Options** and set the units to **SI**. Also click **Show annotation for maximum and minimum in the result plots**.

### 3 Define the fixture.

Select the uppermost faces of the four tabs and the cylindrical faces of the four bolt holes.

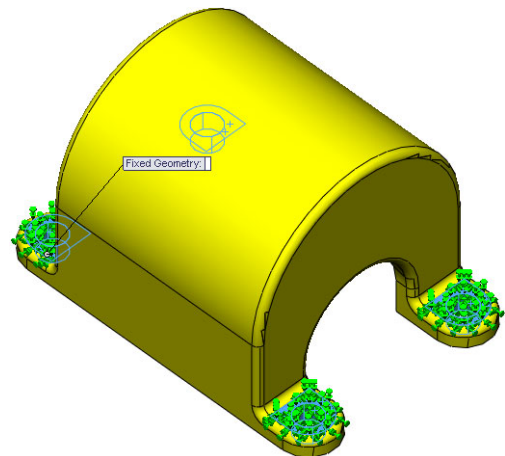

### 4 Define the load set.

Select **Pressure** for the type of load. Right-click one of the faces on the *inside* of the Pump Cover. Click **Select Tangency** from the shortcut menu.

### 5 Set the pressure value and direction.

Set the pressure value to **250 psi**.

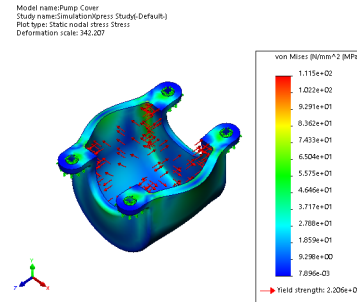
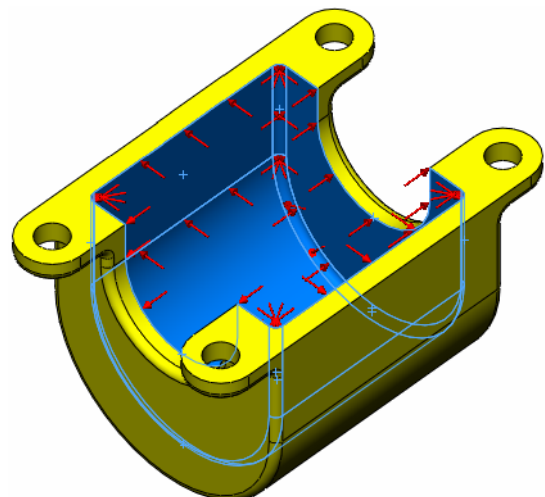

**6 Specify the material.**

Select **Aluminum Alloys** and click **2014 Alloy** from the list.

**7 Run the simulation.****8 Results.**

The factor of safety is less than 1 indicating that the part is overstressed. Also view the stress and displacement plots.

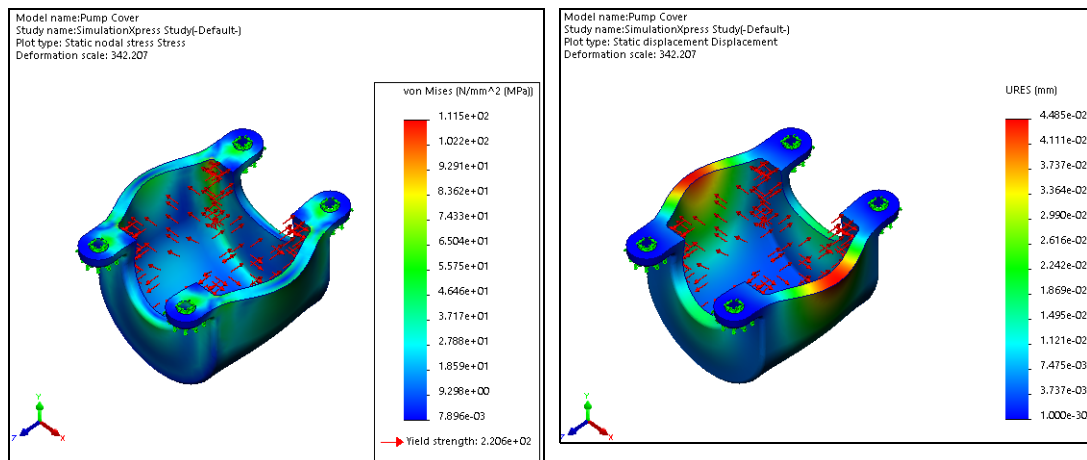
**9 Change the material.**

Right-click the Pump Cover (-2014 Alloy-) icon in the SimulationXpressStudy and click **Apply/Edit Material**.

Change the material to **Other Alloys, Monel(R) 400**.

**10 Update.**

Rerun the study to update the analysis using the new material. The factor of safety should be greater than 1.

**11 Save and close the part.**



# Lesson 6

## Bottom-Up Assembly Modeling

Upon successful completion of this lesson, you will be able to:

- Create a new assembly.
- Insert components into an assembly using all available techniques.
- Add mating relationships between components.
- Utilize the assembly-specific aspects of the FeatureManager design tree to manipulate and manage the assembly.
- Insert subassemblies.
- Use part configurations in an assembly.

## Case Study: Universal Joint

This lesson will examine assembly modeling through the construction of a universal joint. The joint consists of several components and one subassembly.

## Bottom-Up Assembly

*Bottom-Up* assemblies are created by adding and orienting existing parts in an assembly. Parts added to the assembly appear as *Component Parts*. Component parts are oriented and positioned in the assembly using **Mates**. Mates relate faces and edges of component parts to planes and other faces/edges.

## Stages in the Process

Some key stages in the modeling process of this assembly are shown in the following list. Each of these topics comprises a section in the lesson.

- **Creating a new assembly**  
New assemblies are created using the same method as new parts.
- **Adding the first component**  
Components can be added in several ways. They can be dragged and dropped from an open part window or opened from a standard browser.
- **Position of the first component**  
The initial component added to the assembly is automatically fixed as it is added. Others components can be positioned after they are added.
- **FeatureManager design tree and symbols**  
The FeatureManager design tree includes many symbols, prefixes and suffixes that provide information about the assembly and the components in it.
- **Mating components to each other**  
Mates are used to position and orient components with reference to each other. Mates remove degrees of freedom from the components.
- **Subassemblies**  
Assemblies can be created and inserted into the current assembly. They are considered subassembly components.

## The Assembly

In this lesson we will make an assembly using existing components. The assembly is a universal joint, and is made up of a number of individual parts and one subassembly as shown below:

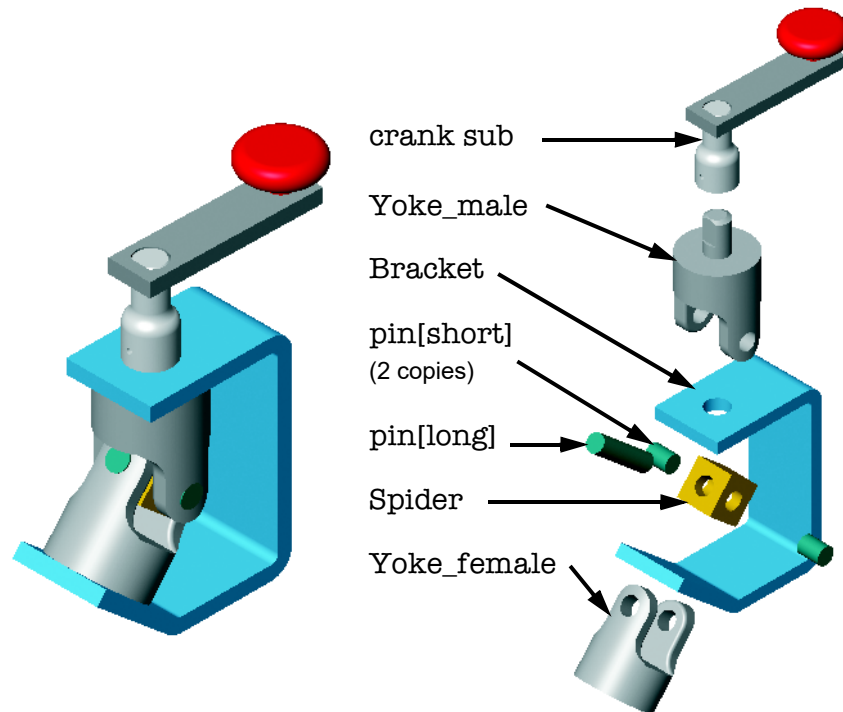

---

### 1 Open an existing part.

Open the part bracket. This part will be the base component of the new assembly.

The first component added to an assembly should be a part that will not move. By fixing the first component, others can be mated to it without any danger of it moving.

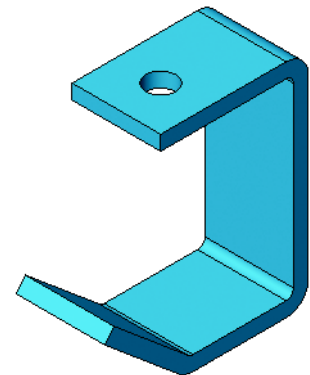

## Creating a New Assembly

New assemblies can be created directly or be made from an open part or assembly. The new assembly contains an origin, the three standard planes and a **Mates** folder.

### Introducing: Make Assembly from Part/Assembly

Use the **Make Assembly from Part/Assembly** option to generate a new assembly from an open part. The part is used as the first component in the new assembly and is fixed in space.

### Where to Find It

- Menu Bar: **New** , **Make Assembly from Part/Assembly** 
- Menu: **File, Make Assembly from Assembly**

### Introducing: New Assembly

A new assembly file can be created by clicking **New**  and selecting an assembly template.

---

## 2 Choose template.

Click **Make Assembly from Part/Assembly** . Use the **Assembly\_MM** template.

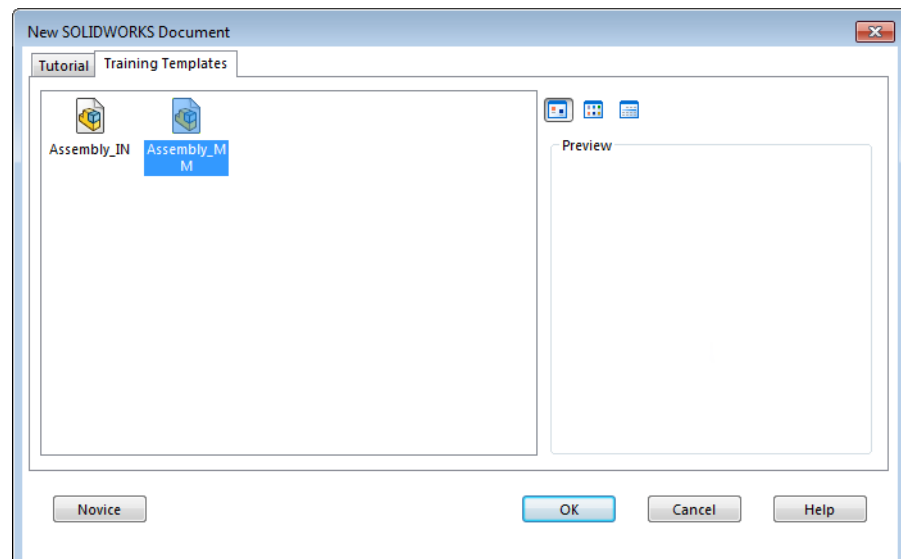

### Note

The units of the assembly can be different from the units of the parts. For example, you can assemble a mixture of inch and millimeter parts in an assembly whose units are feet. However, when you edit the dimensions of *any* of the parts in the context of the assembly, they will be displayed in the units of the assembly, not those of the part itself. Using **Tools, Options**, you can check the units of the assembly and if desired, change them.

**3 Locate component.**

Place the component at the origin by placing the cursor at the origin or by simply clicking **OK**.

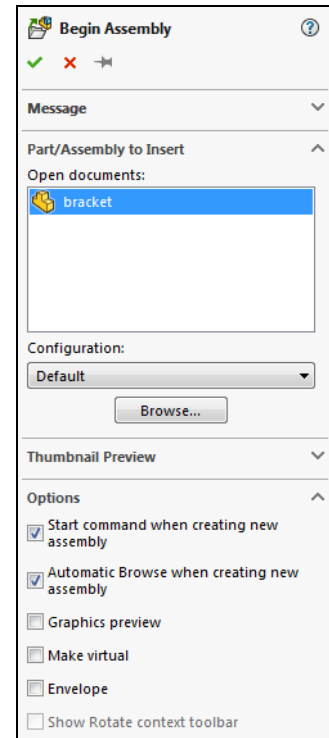
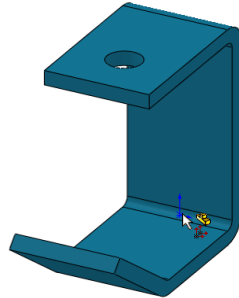
**4 Save.**

Save the assembly under the name Universal Joint. Assembly files have the file extension \*.sldasm.

Close the bracket part file.

## Position of the First Component

The initial component added to the assembly is, by default, **Fixed**. Fixed components cannot be moved and are locked into place wherever they fall when you insert them into the assembly. By clicking the green check or placing the cursor at the assembly origin, the component's origin is at the assembly origin position. This also means that the planes of the component match the planes of the assembly, and the component is fully defined.

Consider assembling a washing machine. The first component logically would be the frame onto which everything else is mounted. By aligning this component with the assembly's planes, we would establish what could be called "product space". Automotive manufacturers refer to this as "vehicle space". This space creates a logical framework for positioning all the other components in their proper positions.

## FeatureManager Design Tree and Symbols

Within the FeatureManager design tree of an assembly, the folders and symbols are slightly different than in a part. There are also some terms that are unique to the assembly.

### Degrees of Freedom

There are six degrees of freedom for any component that is added to the assembly before it is mated or fixed: translation along the X, Y, and Z axes and rotation around those same axes. How a component is able to move in the assembly is determined by its degrees of freedom. The **Fix** and **Insert Mate** options are used to remove degrees of freedom.

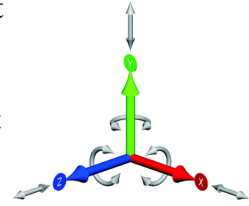

### Components

Parts that are inserted into the assembly, such as the bracket, are represented by the same top-level icon as is used in the part environment. Assemblies can also be inserted and are shown with an assembly icon preceding the assembly document name. However, when the listing of these icons is expanded, the subassembly components and even the component's features are listed and accessible.

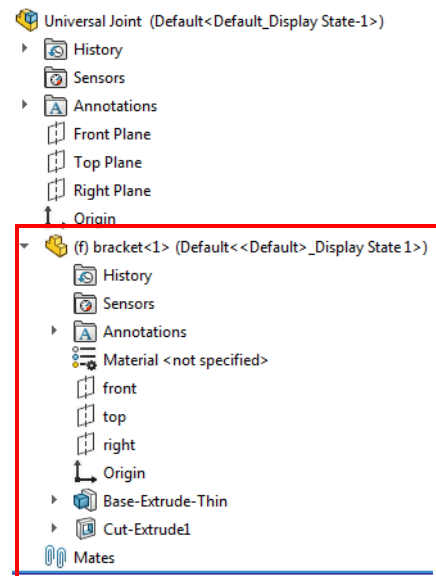

### Component Part Folder

Each component part contains the entire contents of the part, including all features, planes and axes.

### Note

If the component is an assembly, the assembly, including all the parts, would be displayed.

### Component Name

The component name in the FeatureManager design tree displays a wealth of information.

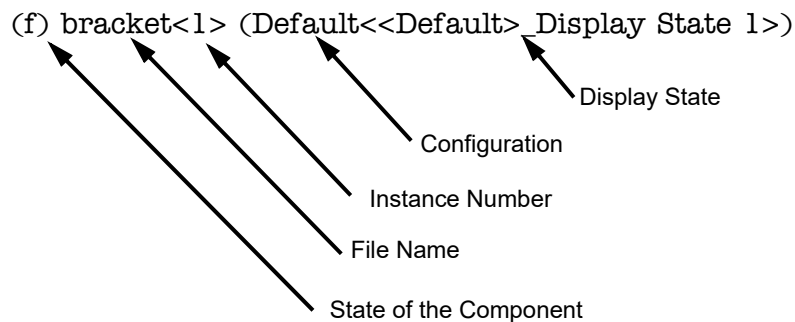

**State of the component**

There are several symbols that are used to represent the state of a component in the Assembly FeatureManager design tree. These are similar to the symbols that represent the state of a sketch.

**Fixed**

The component is **Fixed** to the current position, but it is not mated.

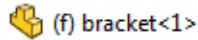
**Under Defined**

The component's position is **Under Defined** and still has some freedom of movement within the assembly.

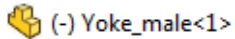
**Fully Defined**

Components that are not marked with a state indicator have a position within the assembly that is **Fully Defined** with mates.

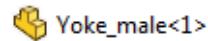
**Over Defined**

Conflicting information for the position of the component will cause it to be **Over Defined**. Another error state is **Not Solved** where a question mark is used as the state indicator.

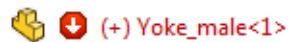
**File Name**

The name of the component, part or assembly, is listed. The icon will show whether it is a part or an assembly. For more information on assemblies, see *Inserting Subassemblies* on page 246.

**Instance Number**

The instance number is used internally to distinguish each instance of the component from each other when multiple instances of the component are included in the assembly.

Instances are *not* renumbered for deletions. The highest instance number may not reflect the total.

**Configuration**

The configuration, Default in this example, is the configuration of the component that is used by this assembly.

**Display State**

The display state, <Default>\_Display\_State1 in this example, is the display state of the component that is used by this assembly.

For more information on configurations and display states in assemblies, see the *Assembly Modeling* manual.

**External References Search Order**

When any parent document is opened, all documents that are referenced by the parent document are also loaded into memory. In the case of assemblies, components are loaded into memory according to the suppression state they were in when the assembly was saved.

The software searches for referenced documents in paths you can specify, the path where you last opened a document, and other paths. If the referenced document is still not found, the software gives you the option to browse for it or open the assembly without the document. See the *Search Routing for Referenced Documents* topic in the online help for a complete list of the paths the software searches.

**Note**

All updated reference paths in the parent document are saved when you save the parent document.

## File Names

File names should be *unique* to avoid bad references. SOLIDWORKS cannot open two different documents with the same name at the same time. Assemblies can use the wrong part if you have two different parts with the same name. Here are two examples:

- Two different parts called `bracket.sldprt` are saved and closed. When you open an assembly that references `bracket.sldprt`, the software will use whichever comes first in the search order.
- A file named `frame.sldprt` is open in SOLIDWORKS. Then, you try to open an assembly that references a different file named `frame.sldprt`. The software gives the following message:

The document being opened references a file with the same name as an already-open document.

You can continue to open the assembly with all instances of `frame.sldprt` suppressed or you can accept the open file as a replacement.

## Note

Components can be renamed in the FeatureManager design tree if the option **Tools, Options, System Options, FeatureManager, Allow component files to be renamed from FeatureManager tree** has been clicked.

## Rollback Bar

The **Rollback Bar** can be used in an assembly to rollback:

- **Assembly planes, axes, sketches**
- **Assembly patterns**
- **In-context part features**
- **Assembly features**

Any features below the marker are suppressed. Individual components cannot be rolled back.

## Reorder

Features of an assembly can be reordered in the same way as part features; using drag and drop. Assembly objects that can be reordered are:

- **Components**
- **Assembly planes, axes, sketches**
- **Assembly patterns**
- **In-context part features**
- **Mates within the **Mates** folder**
- **Assembly features**

## Mates Folder

The mating relationships in assemblies are grouped together into a **Mate Folder** named **Mates**. The mates get solved in the order in which they are listed.

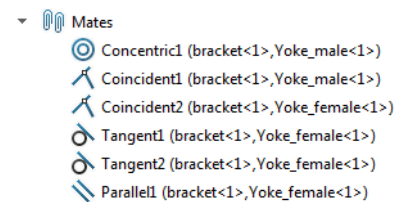

For more information, see *Introducing: Insert Mate* on page 219.

## Adding Components

Once the first component has been inserted and fully defined, other parts can be added and mated to it. In this example, the Yoke\_male part will be inserted and mated. This part should be under defined so that it is free to rotate.

- There are several ways to add components to the assembly:
- Use **Insert Component**
- Drag them from the **Windows**
- Drag them from an open document
- Drag them from the **Task Pane**

All these methods will be demonstrated in this lesson, beginning with use of **Insert Component**. This is the same dialog that appears automatically when **Make Assembly from Part** is used.



### Note

Unlike adding the first component, additional components will be added with their positions under defined.

### Insert Component

The **Insert Component** dialog is used to find, preview and add components to the current assembly. Click the **Keep Visible** (pushpin) button to add multiple components or multiple instances of the same component.

### Where to Find It

- CommandManager: **Assembly > Insert Components**  >  
**Insert Components** 
- Menu: **Insert, Component, Existing Part/Assembly**
- Windows: Drag a component into the graphics area

### 5 Insert Yoke\_male.

Click **Insert Components**  and click the Yoke\_male part using the **Browse** button. Position the component on the screen to the left of the bracket and click to place it.

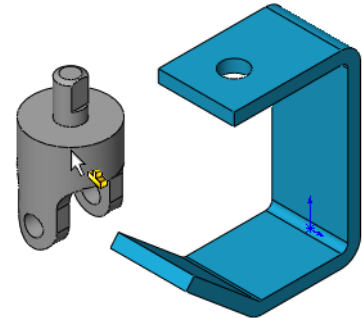

The new component is listed as:

(-) Yoke\_male <1>

This means that the component is the first instance of Yoke\_male and it's position is under defined.

### Tip

Clicking on a component in the FeatureManager design tree will cause that component to highlight. Also, moving the cursor to a component in the graphics window will display the feature name.

## Moving and Rotating Components

One or more selected components can be moved or rotated to reposition them for mating using the mouse, the **Move** and **Rotate Component** commands or the **Triad**.

### Move Using Dynamic Assembly Motion

Also, moving under defined components simulates movement of a mechanism through dynamic assembly motion. See *Dynamic Assembly Motion* on page 234.

### Move

**Move Component** is used to move the component in space.



### Where to Find It

- Mouse Button: Drag a component with the left mouse button
- CommandManager: **Assembly > Move Component** 
- Menu: **Tools, Component, Move**

### Rotate

**Rotate Component** is used to rotate the component in space.

### Where to Find It

- Mouse Button: Drag a component with the right mouse button
- CommandManager: **Assembly > Move Component** , **Rotate Component** 
- Menu: **Tools, Component, Rotate**

### Triad

The **Triad** is used to dynamically move along an axis or rotate about an axis.

### Where to Find It

- Shortcut Menu: Right-click a component and click **Move with Triad**

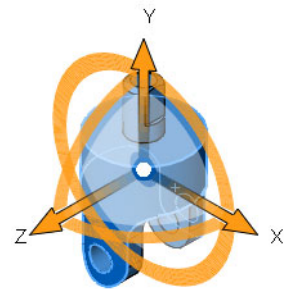

### Note

**Move Component** and **Rotate Component** behave as a single, unified command. By expanding either the **Rotate** or **Move** options, you can switch between the two commands without ever closing the PropertyManager.

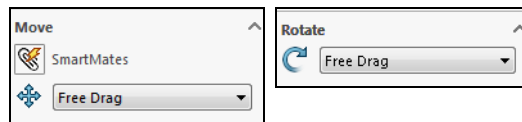

The **Move** tool has several options for defining the type of movement. The option **Along Entity** has a selection box, **Along Assembly XYZ**, **By Delta XYZ**, and **To XYZ Position** require coordinate values.

The **Rotate** tool also has options to define how the component will rotate.

**6 Move.**

Drag the component Yoke\_male with the left mouse button so it is closer to where it will be mated.

Other options for moving and rotating the component will be discussed later in this lesson.

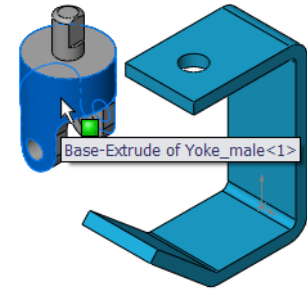

## Mating Components

Obviously dragging a component is not sufficiently precise for building an assembly. Use faces and edges to mate components to each other. The parts inside the bracket are intended to move, so make sure that the proper degrees of freedom are left available.

### Introducing: Insert Mate



**Insert Mate** creates relationships between component parts or between a part and the assembly.

Mates can be created using many different objects. You can use:

- Faces
- Planes
- Edges
- Vertices
- Sketch lines and points
- Axes and origins

Most mates are made between a *pair* of objects. Two of the most commonly used mates are **Coincident** and **Concentric**.

### Where to Find It











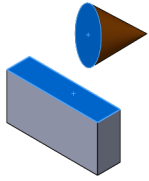

- CommandManager: **Assembly > Mate** 
- Menu: **Insert, Mate**
- Shortcut Menu: Right-click a component and click **Mate** 

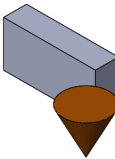
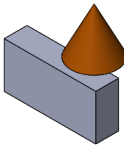
### Note

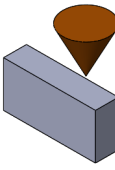
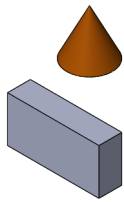
Mates icons are based on their type, for example **Coincident** .

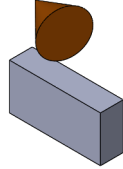
## Mate Types and Alignment

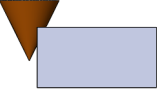
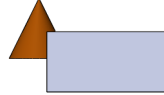

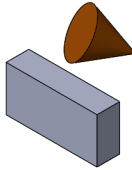
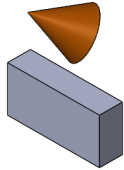

Mates are used to create relationships between components. Faces are the most commonly used geometry in mates. The type of mate, in combination with the conditions **Anti-aligned** or **Aligned**, determines the result.

	Aligned 	Anti-Aligned 
		
<b>Coincident</b>  (faces lie on the same imaginary infinite plane)		
<b>Parallel</b> 		
<b>Perpendicular</b>  Aligned and anti-aligned do not apply to <b>Perpendicular</b> .		
<b>Distance</b> 		
<b>Angle</b> 		

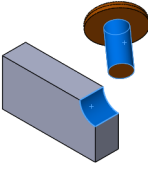
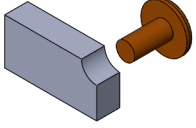
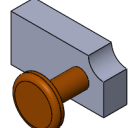

### Note

These tables outline the mates of the **Standard Mates** set. There are also **Advanced Mates** and **Mechanical Mates** sets that are discussed in more advanced manuals.

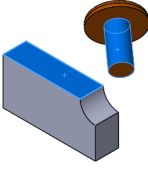
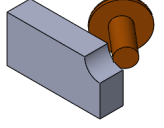
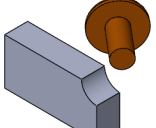
Fewer options are available with cylindrical faces but they are every bit as important.

	Aligned 	Anti-Aligned 
<b>Concentric</b>  		
<b>Tangent</b>  		

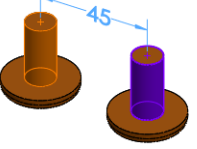
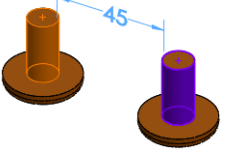
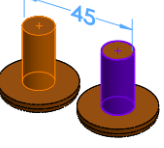
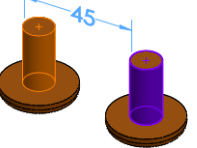
**Distance**  between cylindrical faces has several options.

<b>Center to Center</b>		<b>Minimum Distance</b>	
<b>Maximum Distance</b>		<b>Custom Distance</b>	
<b>Lock</b>  Select anywhere on component.	Components that are locked together will move together. No alignment options.		

**Tip**

After the mate has been created, you can right-click the mate feature in the FeatureManager design tree, and click **Flip Mate Alignment** to reverse the alignment.

**Things to which you can mate**

There are many types of topology and geometry that can be used in mating. The selections can create many mate types.

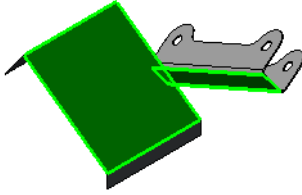
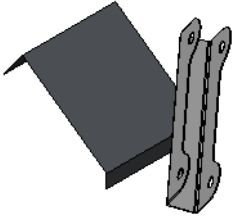
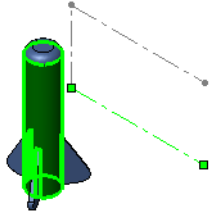
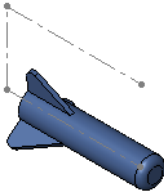
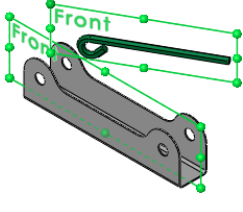
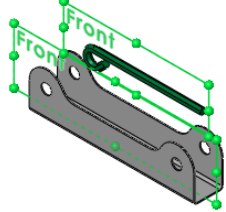
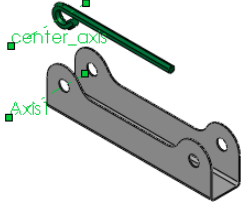
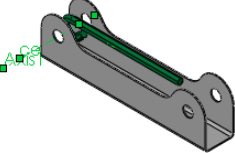
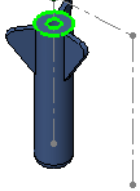
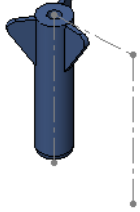
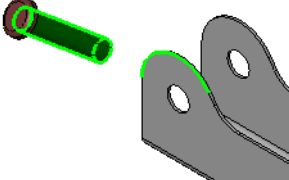
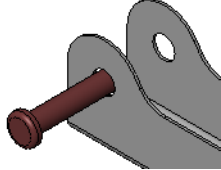
Topology/ Geometry	Selections	Mate
Faces or Surface		
Line or Linear Edge		
Plane		
Axis or Temporary Axis		
Point, Vertex, Origin or Coordinate System		
Arc or Circular Edge		

**Tip** Although planes can be selected on the screen if they are visible, it is often easier to select them by name through the FeatureManager design tree. Click the “+” symbol to see the tree and expand individual components and features.

**Mating Concentric and Coincident** The Yoke\_male component is to be mated so that its shaft aligns with the hole and the flat face contacts the bracket inner face. **Concentric** and **Coincident** mates will be used.

**Tip** Selection filters can be used to limit your selections by geometry type such as face or edge. Press the **F5** key and select one or more filter types.

## 7 Mate PropertyManager.

Click **Mate** . If the PropertyManager is open, you can select the faces without using the **Ctrl** key.

The Standard tab opens by default.

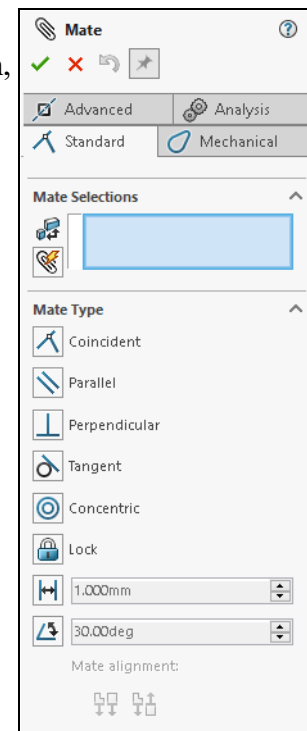

## Mate Options

Several mate options are available for all mates:

- **Add to new folder**

Creates a new folder to hold all the mates created while the **Mate** tool is active. The folder resides in the **Mates** folder and can be renamed.

- **Show pop-up toolbar**

Toggles the Mate pop-up toolbar on and off.

- **Show preview**

Shows the positioning created by the mate as soon as the second selection is made. It is not finalized until the dialog **OK** is clicked.

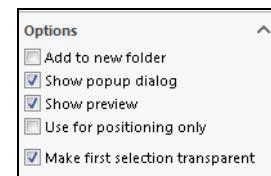

### Introducing: Mate Pop-up Toolbar

#### ■ Use for positioning only

This option can be used to position geometry without constraining it. No mate is added.

#### ■ Make first selection transparent

This option forces the component selected first to be transparent while adding the mate.

The **Mate** pop-up toolbar is used to make selections easier by displaying the available mate types on the screen. The mate types that are available vary by geometry selection and mirror those that appear in the PropertyManager. The mate pop-up toolbar appears on the graphics but can be dragged anywhere.



After the selection, a separate dialog appears (in this example for a Concentric mate) to **Lock Rotation** or **Flip Mate Alignment**.



Either the on-screen or PropertyManager dialog can be used. This lesson uses the on-screen pop-up toolbar. All types are listed in the chart *Mate Types and Alignment* on page 220.

---

### 8 Selections and preview.

Select the cylindrical faces of the Yoke\_male and the bracket as indicated.

As the second face is selected, the mate is previewed by moving to the position that would result from the mate, and the **Mate** pop-up toolbar is displayed.

**Concentric** is selected as the default and the mate is previewed.

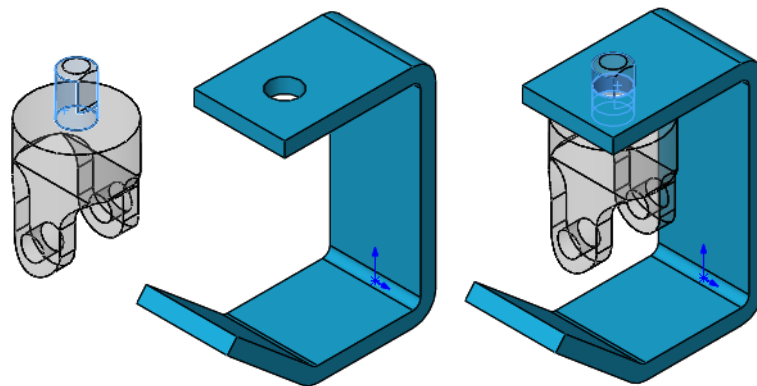

**Note**

When the cursor floats over cylindrical or conical faces, temporary axes appear. These axes can be selected to form a Coincident mate, similar to the Concentric mate.

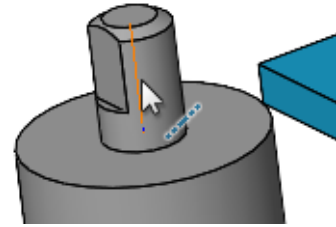
**9 Add a mate.**

The faces are listed in the **Mate Selections** list. Exactly two items should appear in the list. Accept the **Concentric** mate and click **OK**.

**10 Planar face.**

Rotate the view slightly and select the underside planar face of the bracket component.

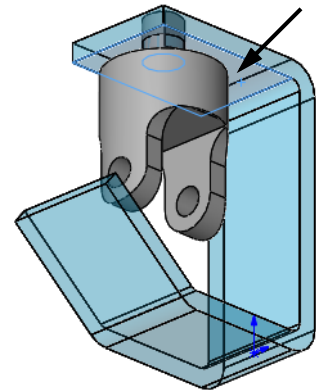
**11 Select through component.**

Return to the Isometric view and select the top face of the Yoke\_male *through* the transparent bracket component. Add a **Coincident** mate to bring the selected faces into contact.

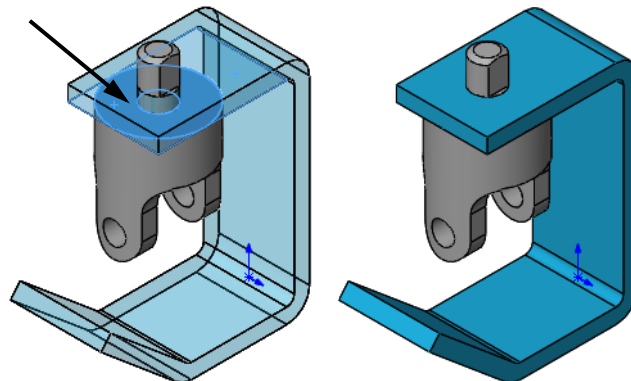
**12 Mates listed.**

The mates, concentric and coincident, remain listed in the **Mates** group box. They will be added to the **Mates** folder when the Mate command is completed. Click **OK**.

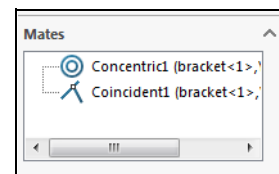

### 13 State of constraint.

The Yoke\_male component is listed as under constrained. It is still able to move by rotating around the axis of its cylindrical surface.

Test the behavior of the Yoke\_male by dragging it.

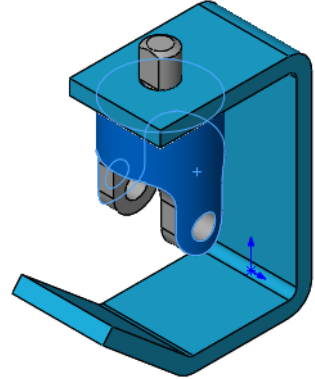

### 14 Breadcrumbs.

Click on a face of Yoke\_male. The Breadcrumbs for that selection appear in the upper left portion of the Graphics Area.

The icon strip identifies the hierarchy upward starting with the face and moving to the feature, body, component, and finally the top level assembly. Below the strip is the sketch associated with the selected *feature*. Above the strip are the mates associated with the selected *component*.

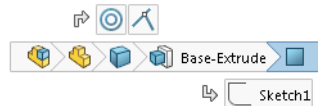
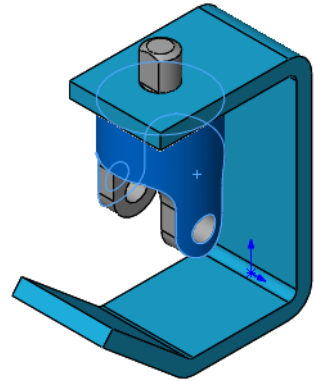

### Note

Right-clicking on any of the icons allows you to edit that feature. Clicking 'air' deselects the face.

**Adding Components  
Using Windows  
Explorer**

Another way to add components to the assembly is through Windows Explorer or My Computer. The part or assembly file(s) can be dragged and dropped into the active assembly.

**15 Open Windows Explorer.**

Since SOLIDWORKS is a native Windows application, it supports standard Windows techniques like “drag and drop”. Component files can be dragged from the window into the assembly to add them. Drag and drop the spider into the graphics area.

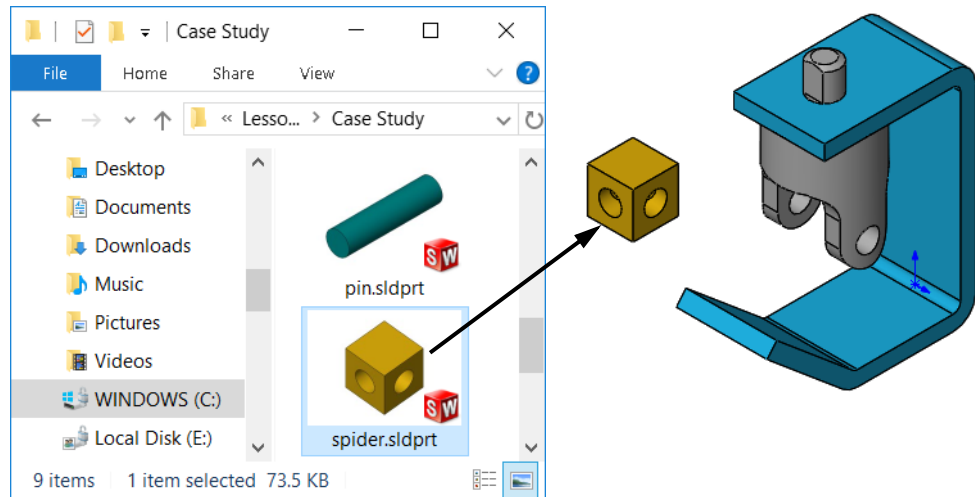
**16 Concentric mate for spider.**

Add a **Concentric** mate between the two cylindrical faces of the spider and Yoke\_male components.

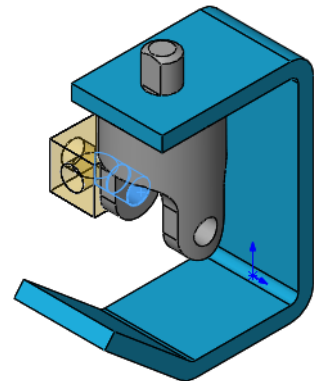

## Width Mate

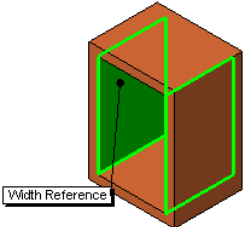
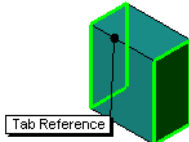
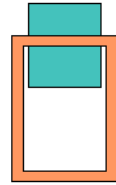
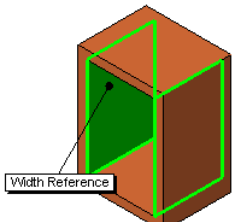
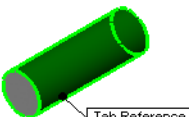
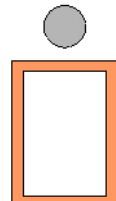
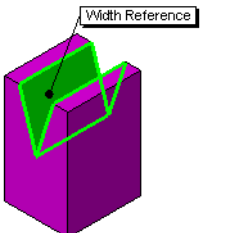
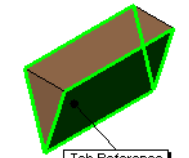
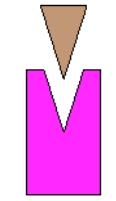

The spider component will be centered within the Yoke\_male and Yoke\_female components using a **Width, Centered** mate. The Width mate is one of the **Advanced Mates** from the **Mate** dialog. Selections include a pair of **Width selections** (the “outer” faces) and a pair of **Tab selections** (the “inner” faces). The **Tab** faces are centered between the **Width** faces to locate the component.

Width selections	Tab selection(s)	Result
 Width Reference	 Tab Reference	 (Front view)
 Width Reference	 Tab Reference (single selection)	 (Front view)
 Width Reference	 Tab Reference	 (Front view)

### Note

The Width mate contains other options that can be used with the same selections: **Free**, **Dimension** and **Percent**.

### 17 Width mate.

Click **Insert Mate**  and click the **Advanced** tab. Click the **Width**  mate and click **Centered**.

Advanced mates often require additional selections; in this example, two pairs of selections are required.

**Hiding Faces with the Alt Key**

There are several ways to select hidden faces when adding or editing mates. The **Alt** key can be used to hide one or more faces and provide access to select hidden faces. The hide is temporary.

**Where to Find It**

- Keyboard Shortcut: Move the pointer over a component face and press **Alt** to hide a face or faces.

**18 Hide and select.**

Click in **Width selections** and click the first of the pair of *inner* faces from the Yoke\_male.

Position the cursor on a face to hide and press the **Alt** key. The outer face is temporarily removed; select through to the inner face.

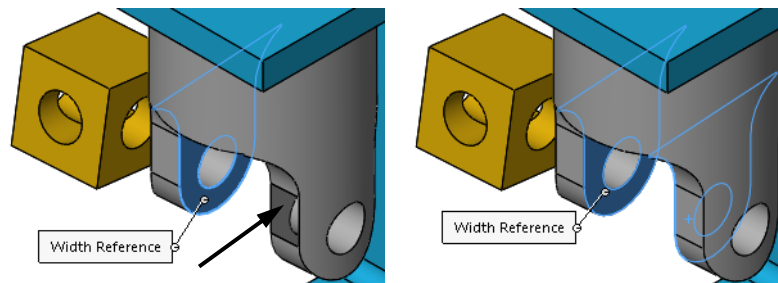
**19 Remaining selections.**

Click in **Tab selections** and click the second of the pair of *outer* faces from the spider as shown. Click **OK**.

The **Width** mate keeps the spider centered inside the Yoke\_male with equal gaps on each side.

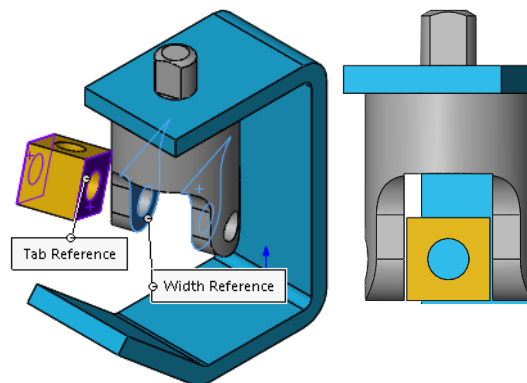

## 20 Mates by component.

Expand the spider component in the FeatureManager design tree. A folder named **Mates in Universal Joint** is added to each component that is mated. The folder contains the mates which use geometry of that component.

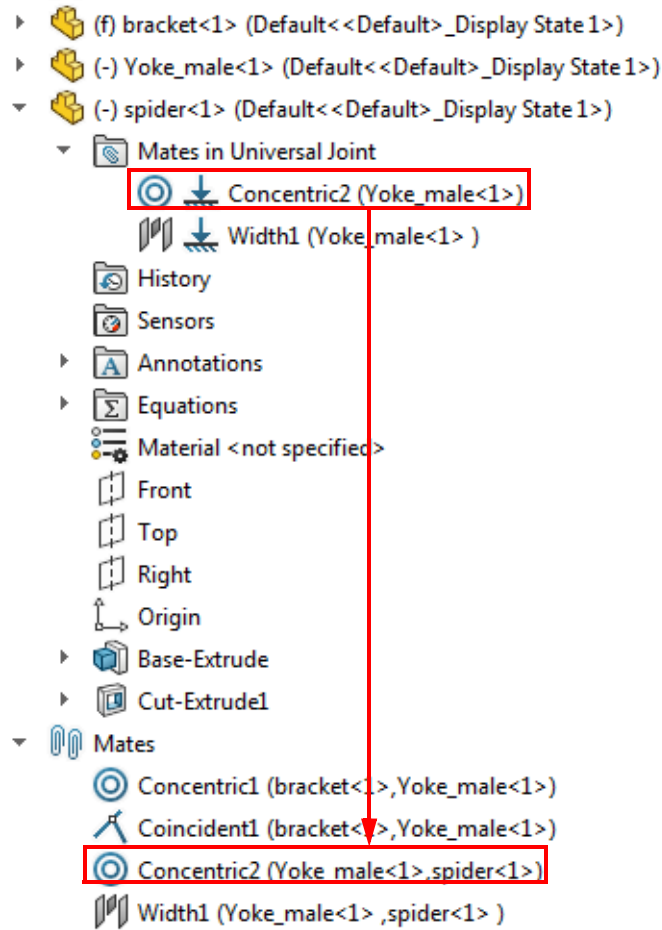

### Note

The icon  indicates that the mate is in the path to ground, or, it is one of the mates that keeps the component in position.

### Rotating Inserted Components

Components inserted using *Insert Component* on page 217 can be rotated after they are inserted but before they are placed using **Rotate Inserted Component**. The angle can be set and the direction buttons can be clicked as many times as desired.

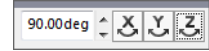

	Rotate about X	Rotate about Y	Rotate about Z

**Where to Find It**

Shortcut Menu: Click **Insert Components** and click a rotation direction

**Note**

The option **Show Rotate context toolbar** on the **Insert Component** PropertyManager must be clicked.

**21 Insert and rotate.**

Click **Insert Components** and select the Yoke\_female part.

Do not click to place the component yet.

Click **Rotate component**

**about Z** twice and click to place the component.

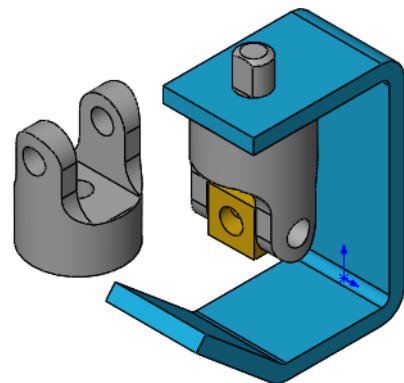

## 22 Concentric mate.

Select the cylindrical faces as shown and add a **Concentric** mate between them.

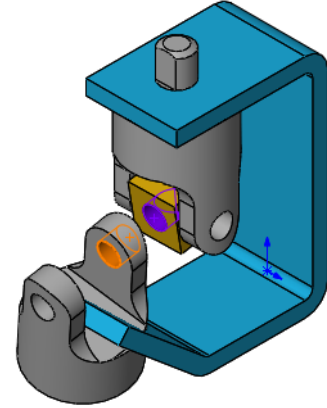

## Using the Component Preview Window

The **Component Preview Window** is a handy tool that can be used to make mate selections easier. When a component is selected for use, a separate viewport is created for the assembly and for the component. Each viewport can be manipulated by zooming, scrolling, and rotating.

### Where to Find It

- Menu: Click a component and click **Tools, Component, Preview Window**
- Shortcut Menu: Right-click a component and click **Component Preview Window** 

## 23 Preview window.

Click the spider component and click

**Component Preview Window** . The window splits to include both the assembly and the spider component. Click **Mate** .

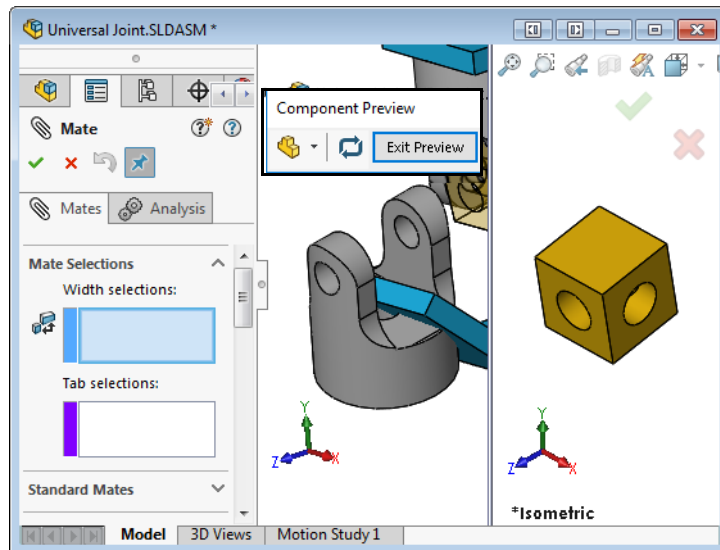

**24 Selections.**

Click **Width**. Select the pairs of faces that make up the width and tab selections. Use view manipulation, the **Alt** key, or select other to make the selections. The spider is centered on the Yoke\_female component. Click **OK**.

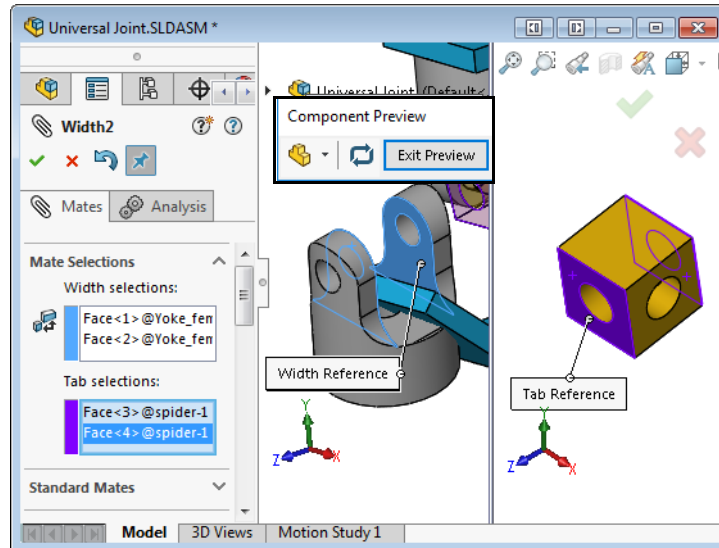
**Note**

The orientation of the component in the **Preview Window** is the same orientation as the assembly.

**25 Exit preview window.**

Click **Exit Preview**.

**Potential Over Defined Condition**

Because of the clearance between the Yoke\_female and the bracket, a **Coincident** mate is unsolvable. The gap prevents coincidence.

**Parallel Mate**

A **Parallel** mate keeps the selected planar faces or planes parallel to each other without forcing contact between them.

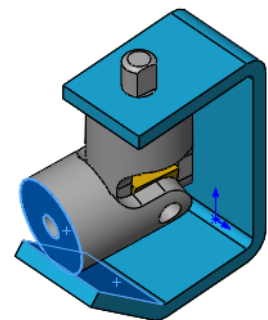

**26 Parallel mate.**

Select the faces of the Yoke\_female and bracket as shown above. Add a **Parallel** mate to maintain the gap between the faces. Press **G** to use the magnifying glass and view the gap.

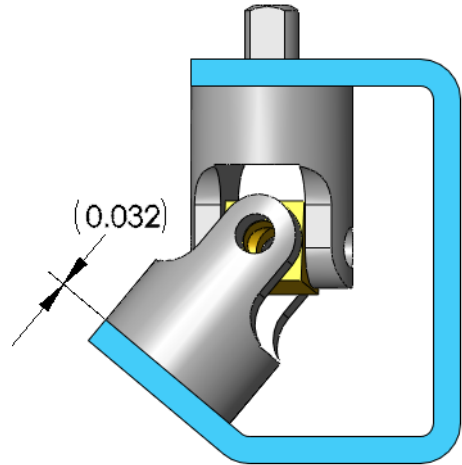
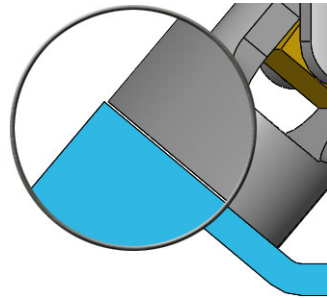

**Dynamic  
Assembly Motion**

Drag under defined components to display the motion allowed by the remaining degrees of freedom.

**Note**

Components that are fixed or fully defined cannot be dragged.

**27 Drag components.**

Drag the Yoke\_male component to turn it. The mated components spider and Yoke\_female move with it.

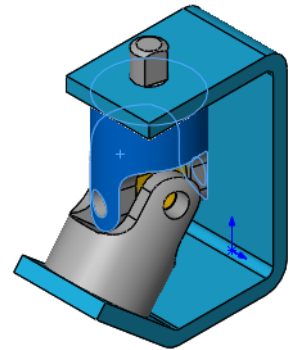

**Displaying Part  
Configurations in  
an Assembly**

When you add a part to an assembly you can choose which of its configurations will be displayed.

Or, once the part is inserted and mated, you can switch its configuration.

## The Pin

The part named pin has two configurations: SHORT and LONG. Any configuration can be used in the assembly. In this case, two instances will use SHORT and one will use LONG.

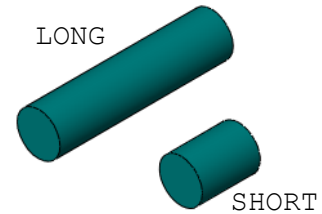

## Using Part Configurations in Assemblies

Multiple instances of the same part can be used in an assembly, with each instance referencing a different configuration. We will use multiple instances of a part with different configurations in this assembly.

There are several ways to create this type of configuration within a part

- Use Modify Configurations.
- Applying different dimension values to individual configurations.
- Design tables.

## Drag and Drop from an Open Document

The pin will be inserted by dragging it in from an open document window into the assembly.

### Note

If the bracket window is still open, close it before the next step.

## 28 Drag and drop.

Open the part pin and tile the windows of the assembly and part. Drag and drop the pin into the assembly window by dragging the top-level component (📁 pin (LONG)) from the FeatureManager design tree. An instance of the pin is added to the assembly.

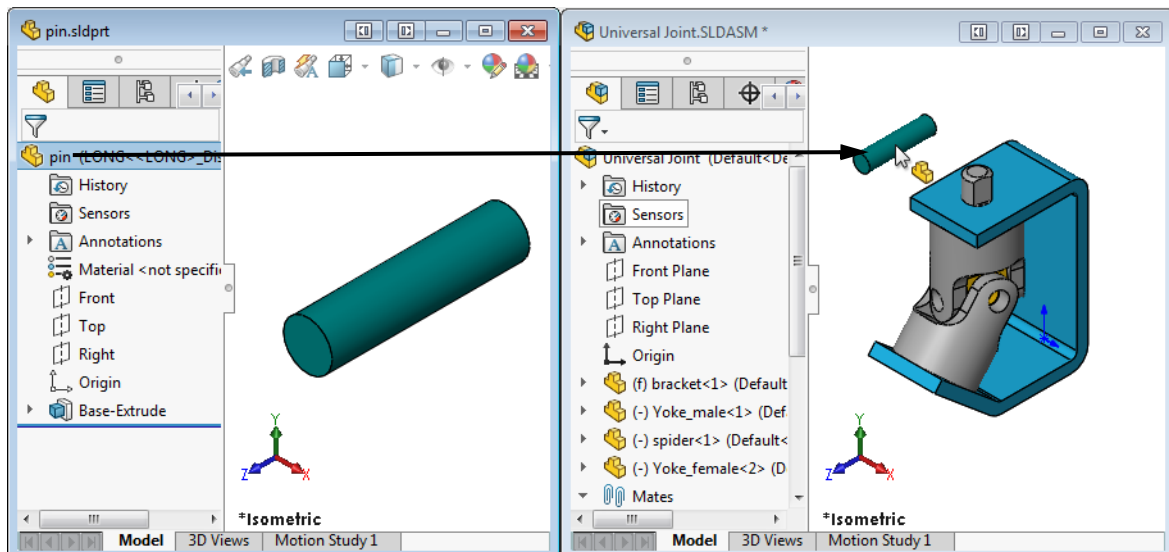

**Important!**

The pin is a component that contains multiple configurations. Like all components, only the configuration that is used (LONG in this case) appears in the component name.

- ▶ (f) bracket<1> (Default<<Default>\_Display State 1>)
- ▶ (-) Yoke\_male<1> (Default<<Default>\_Display State 1>)
- ▶ (-) spider<1> (Default<<Default>\_Display State 1>)
- ▶ (-) Yoke\_female<2> (Default<<Default>\_Display State 1>)
- ▶ (-) pin<1> (LONG<<LONG>\_Display State 1>)
- ▶ Mates

**Note**

Display States are primarily used in assemblies, but can be used in multi-body parts. For more information on display states, see the *Assembly Modeling* training manual.

**29 Concentric mate.**

Select the cylindrical faces as shown. Add a **Concentric** mate between the cylindrical face in the Yoke\_female and pin using the context toolbar.

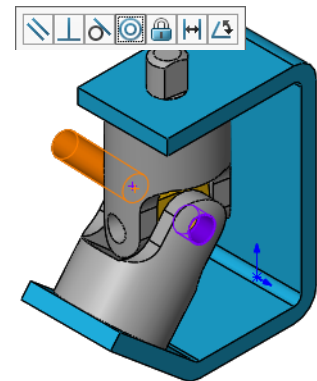

**Note**

To prevent rotation of the pin, click the **Lock Rotation** option.

Drag the pin through the Yoke\_female as shown.

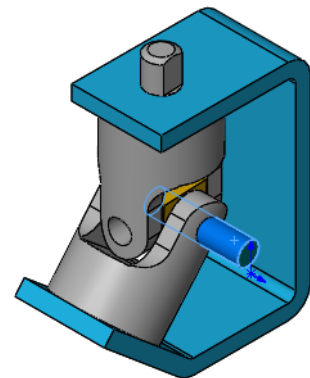

**30 Tangent mate.**

Add a **Tangent** mate between the planar end face of the pin and the cylindrical face in the Yoke\_female using the context toolbar.

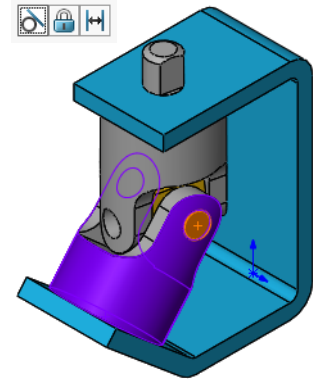
**The Second Pin**

Another instance of the pin is needed. This one will be the shorter version, **SHORT**. We will open the pin, tile the windows of the part and assembly, and show the part's ConfigurationManager.

**Opening a Component**

When you need to access a component while working in an assembly, you can open it directly, without having to use the **File, Open** menu. The component can be either a part or a subassembly.

**31 Cascade the windows.**

Click **Window, Cascade** to see both the part and assembly windows. Switch to the ConfigurationManager of the pin.

**32 Drag and drop a configuration.**

Drag and drop the configuration **SHORT** into the graphics window of the assembly. You can drag and drop *any* configuration from the ConfigurationManager, not just the active one.

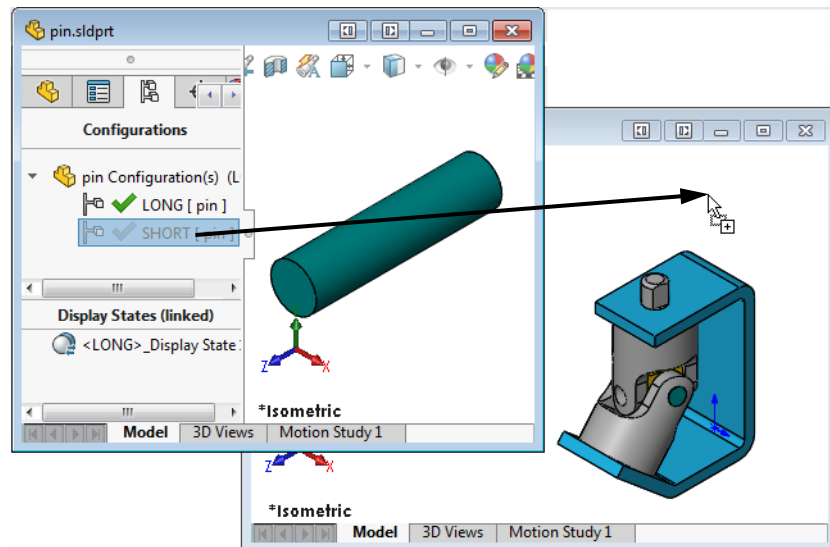

### Other Methods of Selecting Configurations

There are several more methods for selecting the configuration of a component used in an assembly.

- To get the same result using **Insert Component**, browse for the part and associated configuration.
- Parts that contain configurations trigger a message box when dragged and dropped. Select the desired configuration from the list.

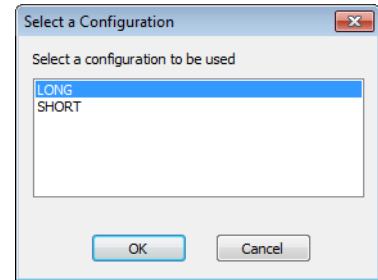

- After the component has been added, click on it and select the configuration name from the context toolbar or **Component Properties** (see *Component Properties* on page 242).



### 33 Second instance.

The second instance of the pin component was added, this time using the **SHORT** configuration. The component is added and it displays the proper configuration name in the FeatureManager design tree.

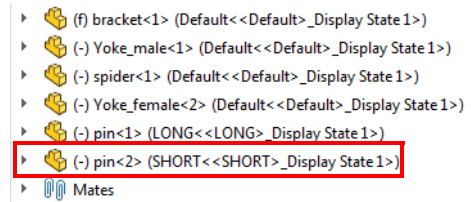

### 34 Mate the component.

Add **Concentric** and **Tangent** mates to mate the second instance of the pin.

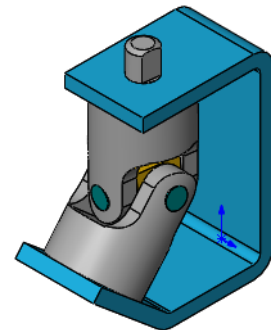

**Recent Documents**

SOLIDWORKS maintains a list of recently opened documents that can be used to access documents quickly. Type the shortcut key **R** and click the document to open.

The pin can be used to keep documents on the recent documents list. The **Show in Folder** link is used to open the folder where the document resides.

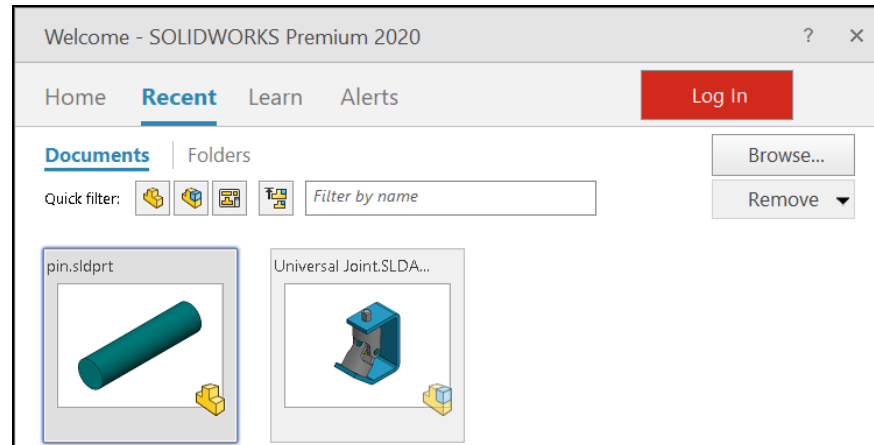
**Where to Find It**

- Keyboard Shortcut: **R**

**Tip**

Clicking  in the lower right hand corner of the image brings up a dialog with several options when opening the file including selection of the mode, configuration, and display state. Clicking **Show in Folder** opens Windows showing the component location.

**35 Switch documents.**

Switch to the **pin.SLDPRT** document, close it and maximize the assembly window.

**Creating Copies of Instances**

Many times parts and subassemblies are used more than once in an assembly. To create multiple instances, or copies of the components, copy and paste existing ones into the assembly.

**36 Drag a copy.**

Create another copy of the pin component by holding the **Ctrl** key while dragging the instance with the **SHORT** configuration into the graphics area. The result is another instance that uses the **SHORT** configuration, since it was copied from a component with that configuration.

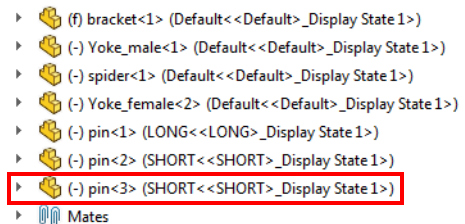
**Tip**

You can drag a copy from the FeatureManager design tree or the graphics area of the assembly.

## Component Hiding and Transparency

Hiding a component temporarily removes the component's graphics but leaves the component active within the assembly. A hidden component still resides in memory, still has its mates solved, and is still considered in operations like mass property calculations.

Another option is to change the transparency of the component. Selections can be made through the component to others behind it.

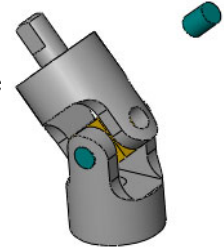

### Introducing: Hide Component Show Component

**Hide Component** turns off the display of a component, making it easier to see other parts of the assembly. When a component is hidden, its icon in the FeatureManager design tree appears in outline form like this:  (f) bracket<1>.



**Show Component** turns the display back on.

### Where to Find It



- Shortcut Menu: Right-click a component and click **Hide Components**  or **Show Components** 
- Display Pane: **Hide/Show**  in the component row
- Keyboard Shortcut. Move the pointer over a component and press **Tab** to hide. Move the pointer over a hidden component and press **Shift + Tab** to display.

### Introducing: Change Transparency

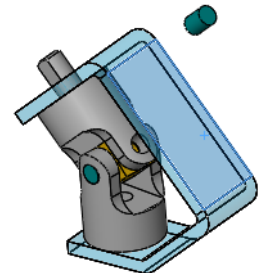
**Change Transparency** toggles the component transparency between **0%** and **75%**. Selections pass through the transparent component unless the **Shift** key is pressed during selection. The FeatureManager design tree icon does not change when a component is transparent.



### Where to Find It

- Shortcut Menu: Right-click a component and click **Change Transparency** 
- Display Pane: **Transparency**  in the component row

---

### 37 Hide the bracket.

Change the view orientation from the default Isometric by pressing **Shift+Left Arrow** once.

Click on the bracket component and

**Hide Component** .

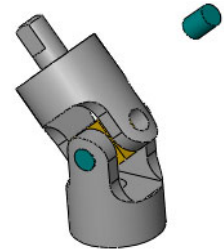

**38 Complete the mating.**

Complete the mating of this component by adding **Concentric** and **Tangent** mates using **Insert Mate**.

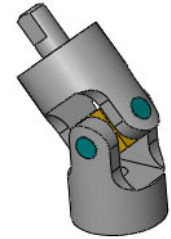

**39 Show the component.**

Select the bracket again and click **Show**

**Component**  to toggle the graphics back on.

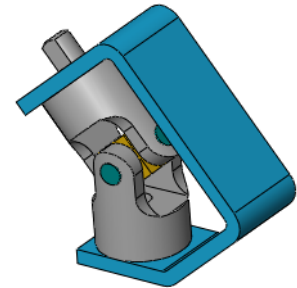

**40 Return to previous view.**

Previous view states can be recalled by clicking **Previous View**  on the Heads-up View Toolbar. Each time you press the button, the view display backs up through the display list, whether the view state was saved or not. Click once to return to the previous Isometric view.

**41 Visual references.**

**Dynamic Reference Visualization** can be used with assemblies to visually identify components from a mate and mates from a component.

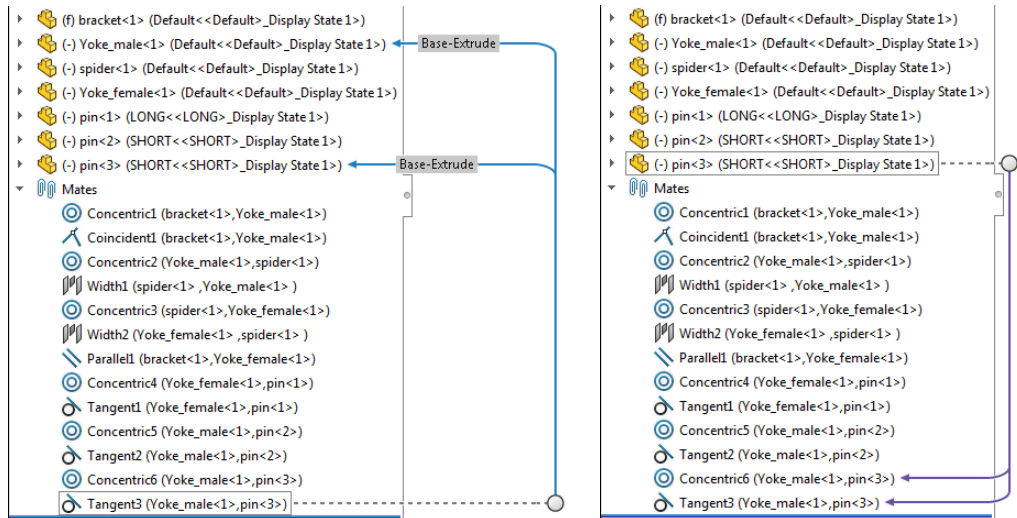

## Component Properties

The **Component Properties** dialog controls several aspects of a component instance.

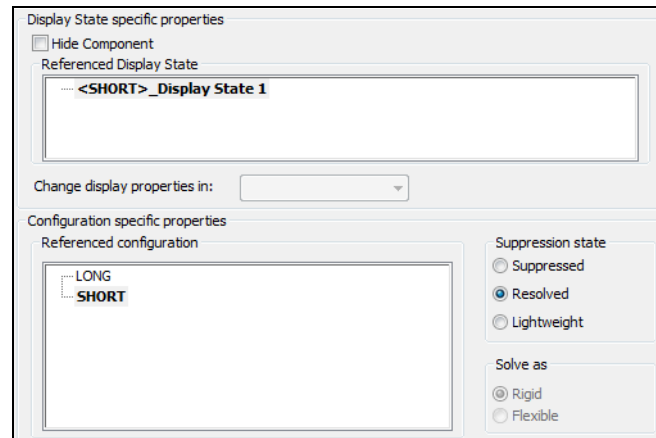

- **Model Document Path**  
Displays the part file that the instance uses. To replace the file instance references with a different file, use **File, Replace**.
- **Display State specific properties**  
Hides or shows the component. Also enables you to select a display state by name.
- **Suppression state**  
Suppress, resolve or set the component to lightweight status.
- **Solve as**  
Makes the subassembly rigid or flexible. This allows dynamic assembly motion to solve motion at the subassembly level.
- **Referenced configuration**  
Determines which configuration of the component is being used.

### Where to Find It

- Shortcut Menu: Right-click a component and click **Component Properties** 

---

#### 42 Component properties.

Right-click the pin<3> component and click

**Component Properties** . The **Referenced configuration** option is set to SHORT. This dialog box can be used to change the configuration, suppress, or hide an instance. Click **Cancel**.

---

## Subassemblies

A new assembly will be created for the components of the crank. It will be used as a subassembly.

Existing assemblies can also be inserted into the current assembly using any of the techniques previously introduced for parts. When an assembly file is added to an existing assembly, we refer to it as a subassembly. However, to the SOLIDWORKS software, it is still an assembly (\*.sldasm) file.

The subassembly and all its component parts are added to the FeatureManager design tree. The subassembly can be mated to the assembly by one of its component parts or its planes. The subassembly is treated as a single piece component, regardless of how many components are within it.

---

### 1 New assembly.

Create a new assembly using the Assembly\_MM template. Click **Keep Visible** on the **Begin Assembly** PropertyManager and add the crank-shaft component. Locate it at the origin of the assembly.

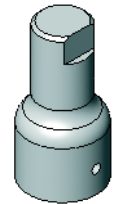

It is **Fixed**.

### 2 Add components.

Using the same dialog, add the crank-arm and crank-knob components.

Close the dialog.

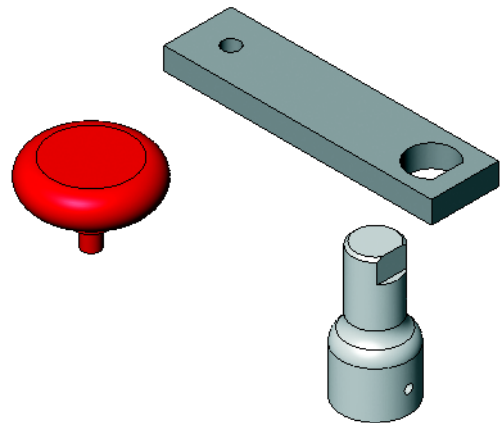

## Smart Mates

Mates can be added between components while dragging and dropping them. This method, called **Smart Mates**, uses the **Alt** key in conjunction with standard drag and drop techniques.

These mates use the same **Mate** pop-up toolbar as the **Mate** tool uses to set the type and other attributes. Many mate types can be created with this method.

Certain techniques generate multiple mates and do not use the toolbar. These require the use of the **Tab** key to switch mate alignment.

### 3 Smart Mate concentric.

Follow these steps to add a **Concentric** mate through the **Smart Mate** technique:

1. Press and hold the **Alt** key.
2. Click and hold the circular face of the crank-arm.
3. Move the component over the circular face of the crank-shaft.
4. Drop the component when the  tooltip appears, indicating a concentric mate.
5. Confirm the **Concentric** type from the **Mate** pop-up toolbar.

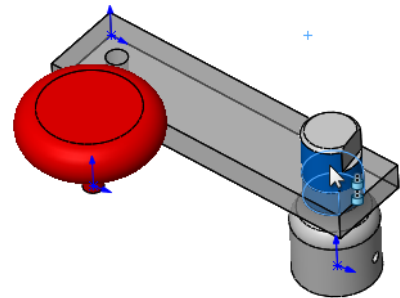

A **Concentric** mate is added between the crank-arm and the crank-shaft components.

### Tip

The **Alt** key can be pressed before or after selecting a face to mate.

### 4 Smart Mate parallel.

Spin the crank-arm around so the flat of the "D" cut is selectable using dragging. Select the flat and **Alt+drag** it to the flat on the crank-shaft. Drop the component when the  symbol appears, indicating a **Coincident** mate between planar faces.

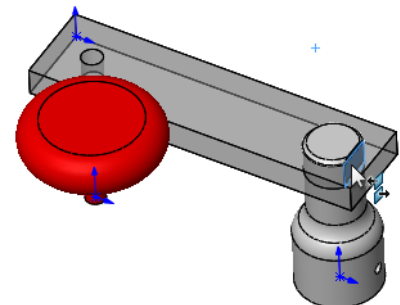

Use the **Mate** pop-up toolbar to *switch* to a **Parallel** mate.

**5 Coincident.**

Select the *edge* of the crank-arm and **Alt+drag** it to the flat on the crank-shaft. Drop the component when the  symbol appears, indicating a **Coincident** mate between an edge and a planar face. Use the **Mate** pop-up toolbar to confirm the **Coincident** mate.

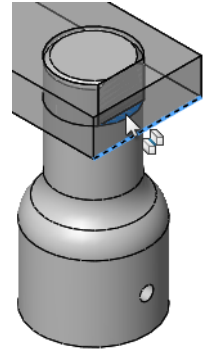
**6 “Peg-in-hole”.**

Rotate the crank-knob using **Move with Triad** (*Triad* on page 218).

The “Peg-in-hole” option is a special case of the **Smart Mate** that creates two mates from one drag and drop. This operation is easier if the crank-knob has been rotated.

Select the circular edge on the crank-knob. Press **Alt** and drag it to the circular edge on the top of the crank-arm.

Release the **Alt** key when the  symbol appears, indicating that both **Coincident** and **Concentric** mates will be added.

Press the **Tab** key, if necessary, to reverse the alignment. Drop the component.

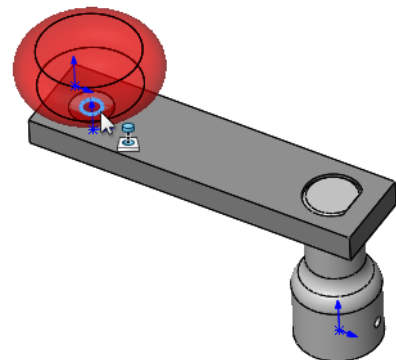
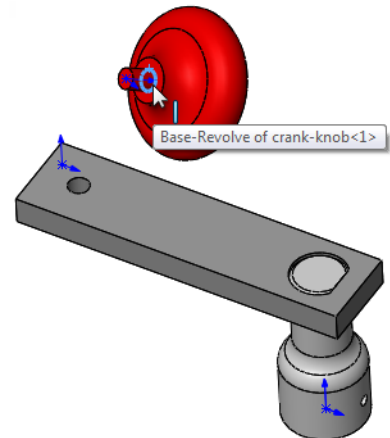
**7 Save.**

Save the assembly, naming it crank sub. Leave the assembly open.

**Hide and Show All Types**

All of the visual symbols used in SOLIDWORKS including: axes, coordinate systems, origins, planes, and sketches can be toggled on and off all at once using **Hide All Types** and **Show All Types**. Currently the only visible type are the blue **View Origins**.

**Where to Find It**

- Heads-up View Toolbar: **Hide All Types** 
- Menu Bar: **View, Hide/Show, Hide All Types**

### 8 Hide all types.

Click **Hide All Types**  to toggle all the visual symbols in this assembly off.

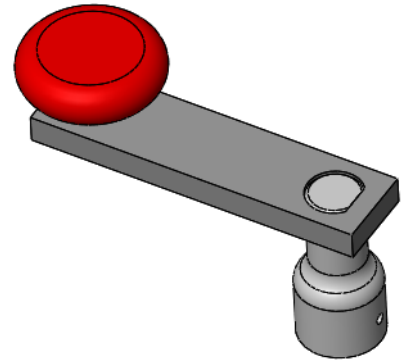

## Inserting Subassemblies

Subassemblies are existing assemblies that are added to the active assembly. All of the subassembly components act as a single component.

### 9 Select the subassembly.

Switch to the main assembly. Using **Insert Component**, the dialog is set to list any open parts or assemblies under **Open documents**. The crank sub is listed and selected.

### 10 Place the subassembly.

Place the subassembly near the top of the Yoke\_male component. Expanding the subassembly component icon shows all the component parts within it, including its own mate group.

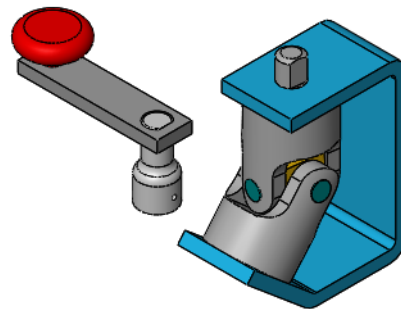

- ▶ (f) bracket<1> (Default<<Default>\_Display State 1>)
- ▶ (-) Yoke\_male<1> (Default<<Default>\_Display State 1>)
- ▶ (-) spider<1> (Default<<Default>\_Display State 1>)
- ▶ (-) Yoke\_female<2> (Default<<Default>\_Display State 1>)
- ▶ (-) pin<1> (LONG<<LONG>\_Display State 1>)
- ▶ (-) pin<2> (SHORT<<SHORT>\_Display State 1>)
- ▶ (-) pin<3> (SHORT<<SHORT>\_Display State 1>)
- ▼ (-) crank sub<1> (Default<Default>\_Display State-1>)
- ▶ History
- ▶ Sensors
- ▶ Annotations
- ▶ Front Plane
- ▶ Top Plane
- ▶ Right Plane
- ▶ Origin
- ▶ (f) crank-shaft<1> (Default<<Default>\_Display State 1>)
- ▶ crank-arm<1> (Default<<Default>\_Display State 1>)
- ▶ (-) crank-knob<1> (Default<<Default>\_Display State 1>)
- ▶ Mates
- ▶ Mates

## Mating Subassemblies

Subassemblies follow the same rules for mating as parts. They are considered components and can be mated using the **Mate** tool, **Alt+drag** mating or any of the other methods that have been discussed.

### 11 Smart Mate concentric.

Add a **Concentric** mate, using **Alt+drag**, between the cylindrical surfaces of the post on the top of the Yoke\_male and the crank-shaft.

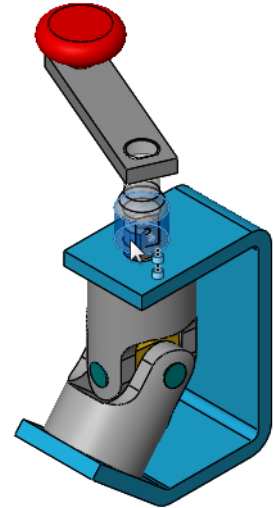

### 12 Parallel mate.

**Mate** the flat on the Yoke\_male with the flat in the D-hole in the crank-shaft with a **Parallel** mate.

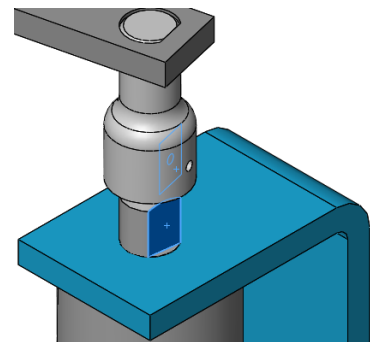

### 13 Alignment.

Click the **Flip Mate Alignment** button to test **Anti-Aligned** (above) and **Aligned** (right).

Use the anti-aligned condition (above) for this mate.

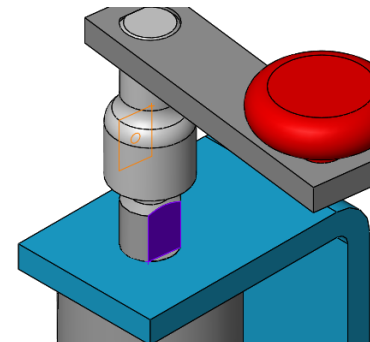

## Distance Mates

**Distance** mates allow for gaps between mating components. You can think of it as a parallel mate with an offset distance. There is generally more than one solution so the options **Flip Mate Alignment** and **Flip Dimension** are used to determine how the distance is measured and which side it is on.

## Unit System

The **Unit System** controls input to the document as well as the units of mass property calculations. The unit system can be set using **Tools, Options, Document Properties, Units**. You can also set the unit system by clicking **Unit System** on the status bar.

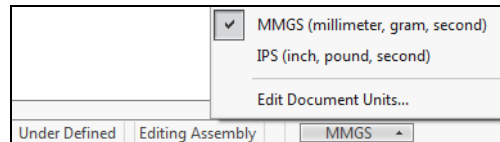

Alternatively, you can enter dimensions in a unit system other than the document's units. In the dimension value fields, you can type the abbreviation for the desired units, or choose the units from a drop down list.

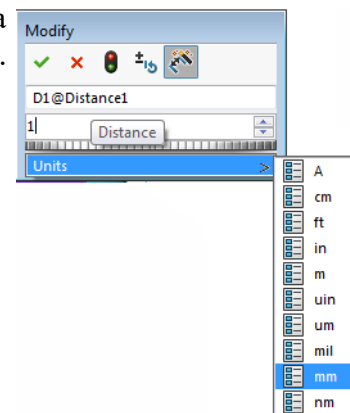

### 14 Select the faces.

Select the top face of the bracket and the bottom face of the crank-shaft component to create the mate.

### 15 Add a Distance mate.

Specify a distance in units that are different than the document's units. Type **1/32 in**. If the crank-shaft penetrates into the bracket select the **Flip Dimension**  button. Click **OK** to create the mate.

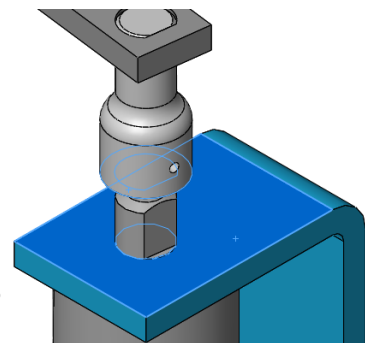

## Tip

Double-clicking a **Distance** or **Angle** mate in the FeatureManager design tree displays it on the screen. The value displays in the units of the assembly, in this case millimeters.

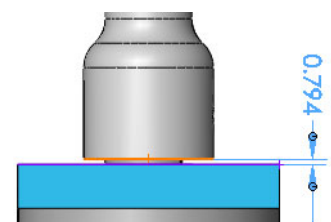

**16 Select in the FeatureManager design tree.**

Select the subassembly crank sub in the FeatureManager design tree. All components in the subassembly will be selected and highlighted.

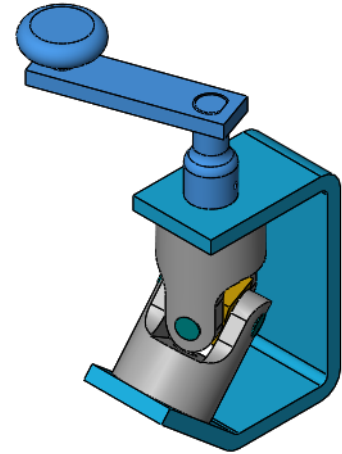
**Tip**

From the graphic window, right-click a component of the subassembly and click **Select subassembly**.

**17 Dynamic Assembly Motion.**

Use **Change Transparency** on the yokes. Drag the crank-arm to see the motion of the spider.

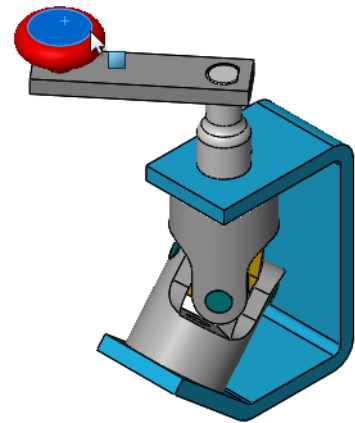
**Use For Positioning Only**

The mate option **Use for positioning only** can be used to position geometry without adding the restriction of a mate. This is a useful method for setting up a drawing view.

**18 Mate.**

Click **Mate**  and click **Use for positioning only**. Select the planar faces shown and a **Parallel** mate. Click **OK**.

The geometry is positioned like a parallel mate condition but no mate is added.

Save the assembly.

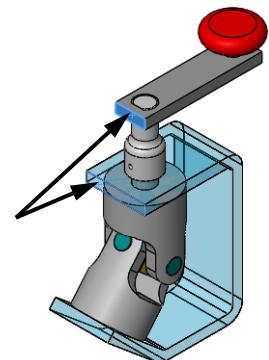

## Pack and Go

**Pack and Go** is used to collect and copy all the files used by the assembly into a single folder or zip file. It is especially useful when the entire assembly must be sent to another user and the files are stored in many different folders. Additional related files can be included.

### Where to Find It

- Menu: **File, Pack and Go**

### 19 Pack and Go.

Click **Pack and Go** and click **Save To Zip File**. Use a file name of your choice, click **Flatten to single folder**, and click **Save**.

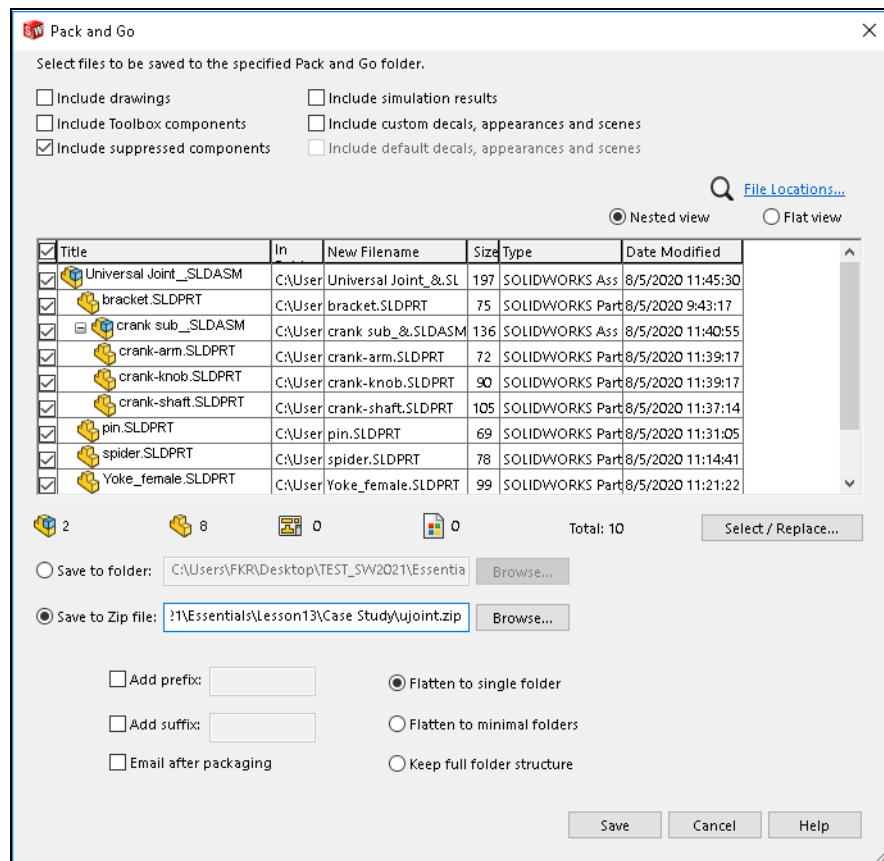

### 20 Save and close all files.

**Exercise 25:  
Mates**

Create this assembly by adding components to a new assembly and using mates.

This lab uses the following skills:

- *Creating a New Assembly* on page 212
- *Adding Components* on page 217
- *Mating Components* on page 219

Units: **millimeters**

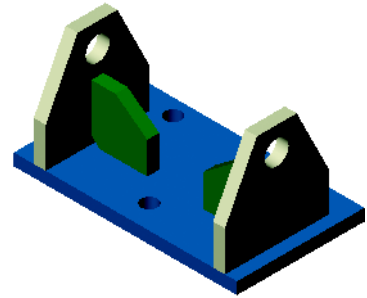
**Procedure**

Create a new assembly. All the component parts can be found in the folder *Mates*.

**1 Add the component RectBase.**

Create a new assembly, using the RectBase part as the base component. It should be fixed at the assembly origin.

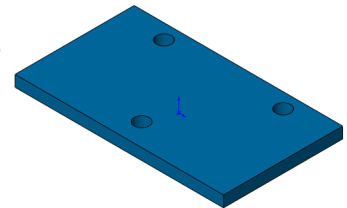
**2 Add the EndConnect.**

Add an instance of the EndConnect to the assembly. **Mate** it to the RectBase using a distance of **10mm** and two coincident mates as shown.

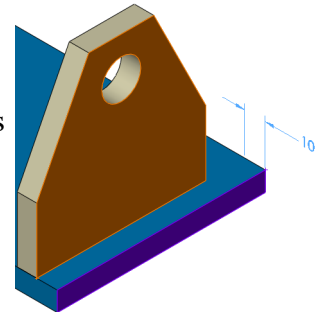
**3 Add the Brace.**

Add an instance of the Brace to the assembly. **Mate** it to the RectBase using coincident mates as shown.

The Brace is centered on the hole in the EndConnect component.

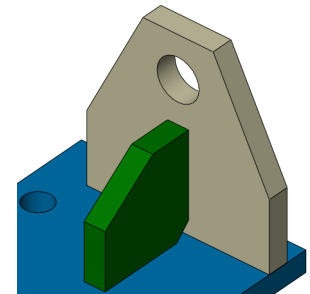
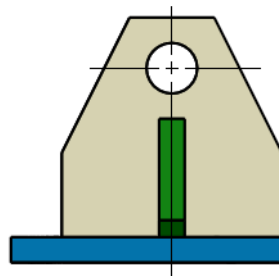
**Tip**

Coincident mates between planes or Width mates can be used to center components.

**4 Additional components.**

Add more instances of the Brace and EndConnect components, placing them as shown.

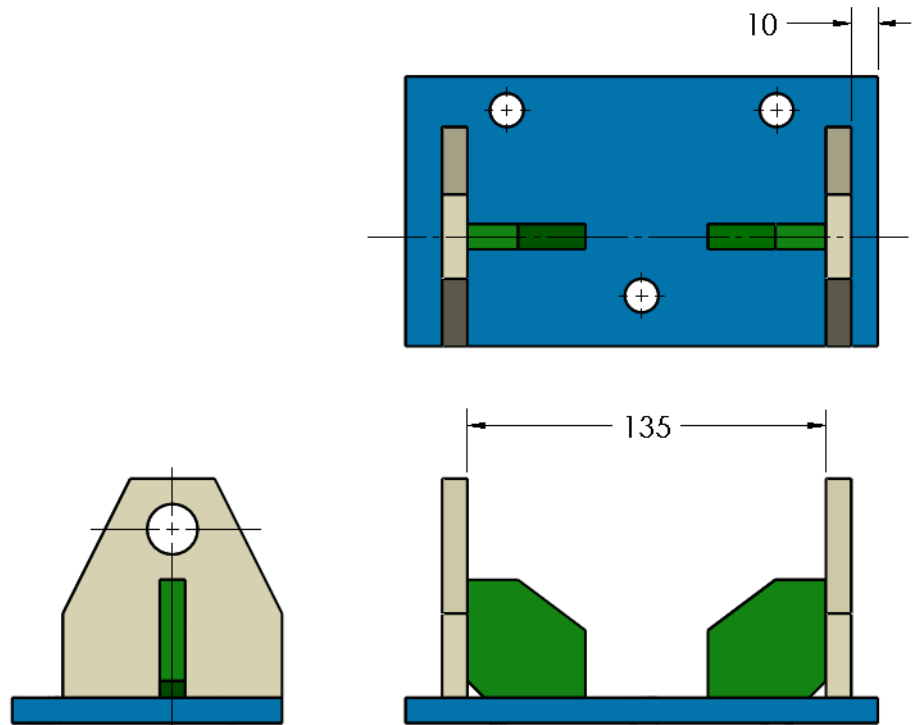

**5 Save and close all files.**

**Exercise 26:  
Gripe Grinder**

Assemble this device by following the steps as shown.

This lab uses the following skills:

- *Creating a New Assembly* on page 212
- *Adding Components* on page 217
- *Mating Components* on page 219
- *Dynamic Assembly Motion* on page 234
- *Smart Mates* on page 244

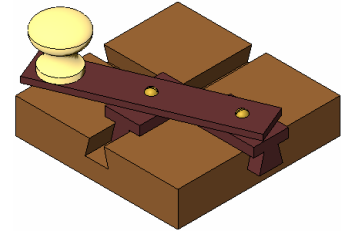

Units: **millimeters**

**Procedure**

Create a new assembly. All the component parts can be found in the folder Grinder Assy.

**1 Add the component Base.**

Create a new assembly, using the Base part as the base component. It should be fixed at the assembly origin.

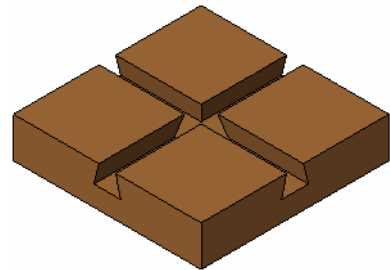
**2 Add the Slider.**

Add the Slider to the assembly. **Mate** it to one of the dovetail slots. A width and coincident mate are required.

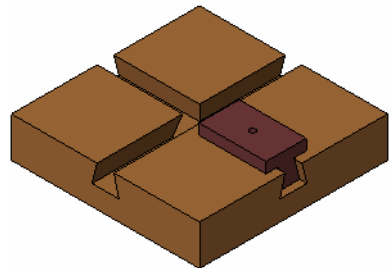
**3 Add a second copy of the Slider.**

**Mate** it to the other dovetail slot. Both Sliders should be free to move back and forth in their respective slots.

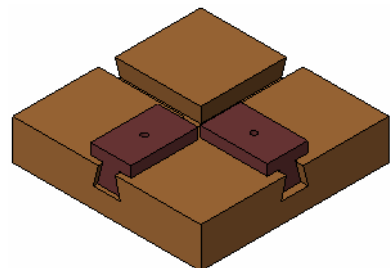

**4 Crank assembly.**

Open a new assembly using the Assembly\_MM template. Build the Crank assembly as shown at the right. Consider using “peg-in-hole” SmartMates to add the coincident and concentric mates in one step. The Crank is shown in both exploded and collapsed states.

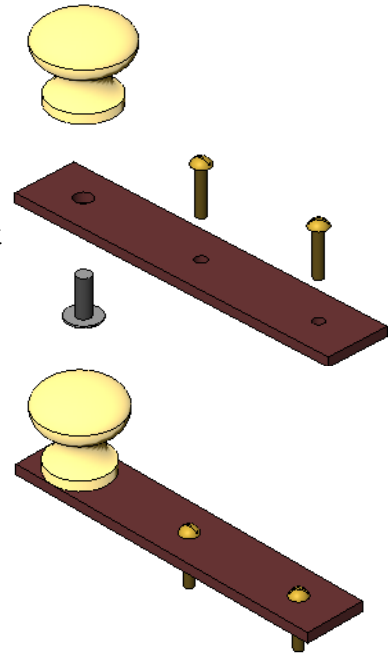

The Crank assembly consists of:

- Handle (1)
- Knob (1)
- Truss Head Screw (1)  
[#8-32 (.5” long)] configuration
- RH Machine Screw (2)  
[#4-40 (.625” long)] configuration

**Note**

Both machine screws contain multiple configurations. Be sure you use the correct ones.

**5 Insert the Crank assembly into the main assembly.**

Tile or cascade the two assembly windows, and drag and drop the subassembly into the main assembly.

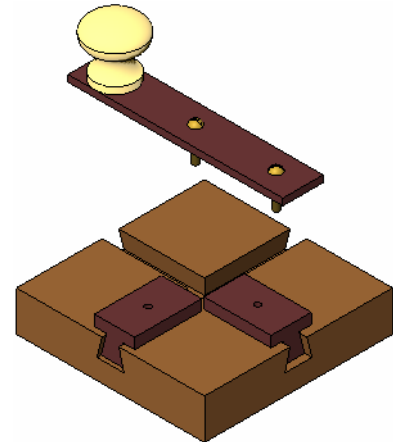

**6 Mate the Crank assembly to the Sliders.**

The two RH Machine Screws go into the holes in the Sliders. The underside of the Handle mates to the top face of one of the Sliders.

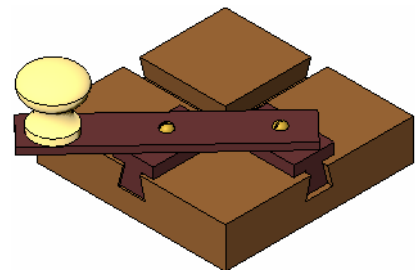

**7 Turn the Crank.**

The movement of the Knob follows an elliptical path. The movement of each Slider traces the major and minor axes of that ellipse.

**8 Save and close all files.**

## Exercise 27: Using Hide and Show Component

Create this assembly by using mates.

This lab uses the following skills:

- *Creating a New Assembly* on page 212.
- *Adding Components* on page 217
- *Mating Components* on page 219
- *Component Hiding and Transparency* on page 240
- *Smart Mates* on page 244

Units: **millimeters**

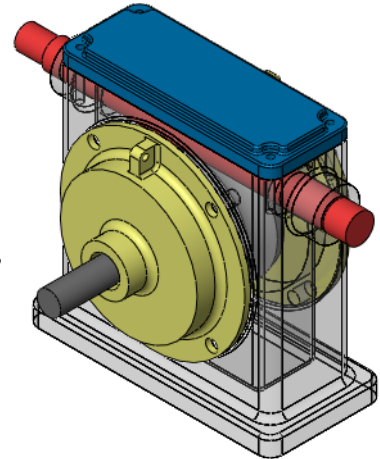

### Procedure

Create a new assembly. All the component parts can be found in the folder Gearbox Assy.

#### 1 Create assembly.

Open the Housing component. Use **Make Assembly from Part/Assembly** to create a new assembly with the `Assembly_MM` template. It should be fixed at the assembly origin.

#### 2 Add the components.

Drag or insert the remaining component parts into the assembly.

#### 3 Mates.

Mate the Cover Plate and both Cover\_Pl&Lug components to the Housing as shown.

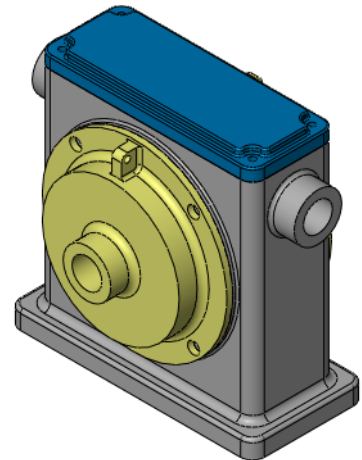

- 4 Hide.**  
Hide the Cover Plate and one of the Cover\_Pl&Lug components as shown.
- 5 Add more components.**  
Add the Worm Gear Shaft and Worm Gear components as shown.

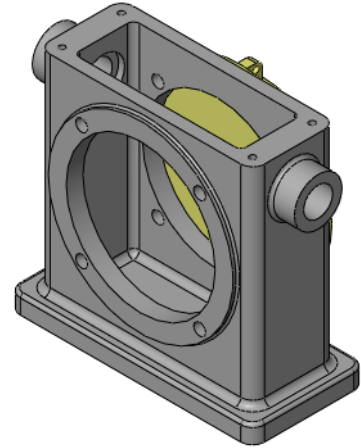

**Tip**

Mate the Worm Gear to the Housing using a **Width** mate.

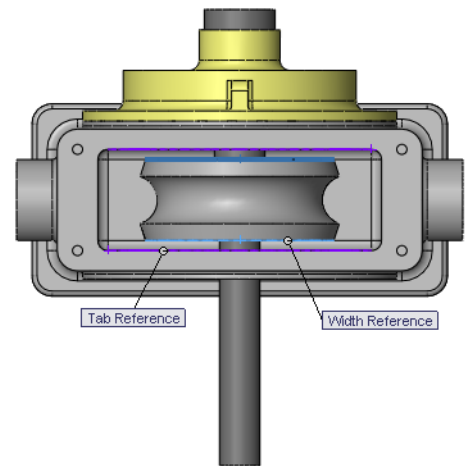

- 6 Detail.**  
Show the hidden components. Use **Change Transparency** to change the appearance of the Housing.  
Add the Offset Shaft component and mate it.

**Tip**

A detail for mating the Offset Shaft to the Housing is shown at right.

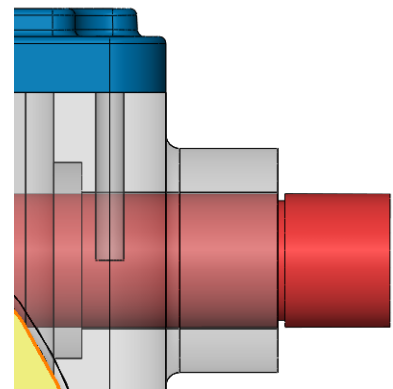

- 7 Save and close all files.**

## Exercise 28: Part Configurations in an Assembly

Using the parts included, complete this bottom up assembly. Use several configurations of the same part in the assembly to create a set of allen wrenches.

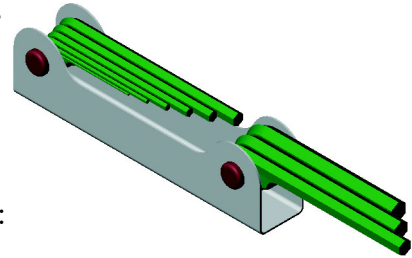

This lab reinforces the following skills:

- *Adding Components* on page 217
- *Mating Components* on page 219
- *Using Part Configurations in Assemblies* on page 235
- *Opening a Component* on page 237

### Procedure

Open an existing assembly.

#### 1 Existing assembly.

Open the assembly part configs from folder part configs. The assembly contains three components, two of which have multiple instances. One component, the Allen Wrench, uses a different configuration for each instance.

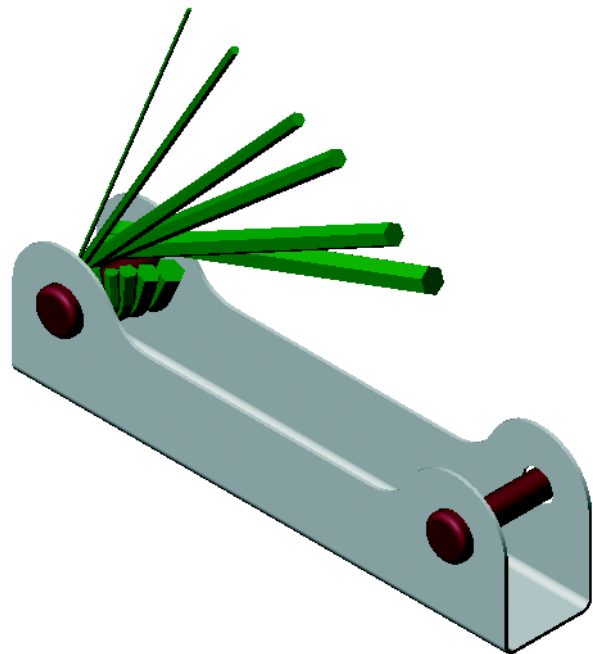

#### 2 Open part.

Select any instance of the Allen Wrench component and open the part.

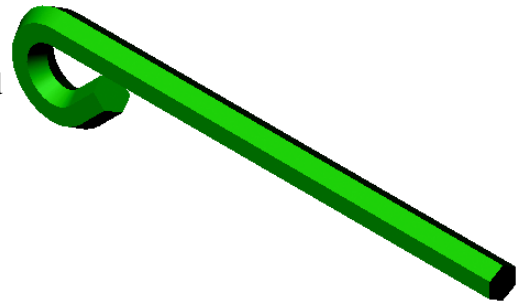

### 3 Configuration.

Use the values in the Length column for each configuration as shown.

	Length
Size01	50
Size02	60
Size03	70
Size04	80
Size05	90
Size06	100
Size07	100
Size08	90
Size09	80
Size10	100

**Tip**

Right-click the dimension and click **Configure Dimension**.

### 4 Add and mate components.

Add and mate three more components, noting the configurations of the Allen Wrench parts. The sizes, positions and part names are detailed in the accompanying illustrations.

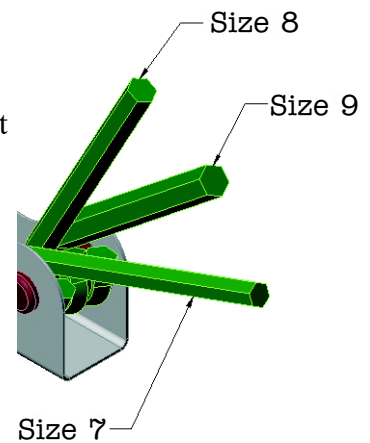

**Tip**

The Allen Wrench axis center\_axis is useful for mating.

### 5 Save and close all files.

## Exercise 29: U-Joint Changes

Make changes to the assembly created in the previous lesson.

This exercise uses the following skills:

- *Insert Component* on page 217
- *Mating Components* on page 219
- *Opening a Component* on page 237
- *Component Hiding and Transparency* on page 240

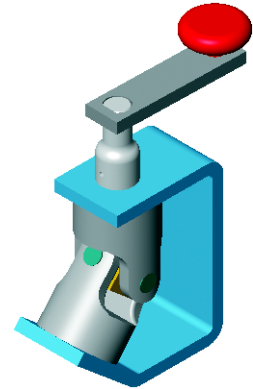

### Procedure

Open an existing assembly.

**1 Open the assembly named Changes.**

Open the assembly Changes from folder U-Joint Changes.

**2 Open the bracket component.**

From the FeatureManager design tree or the screen, open the component bracket<1> for editing.

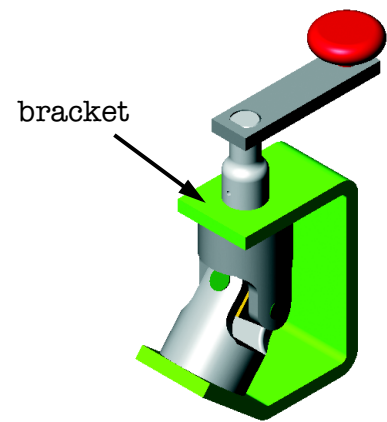

**3 Changes.**

Double-click the first feature and change the dimensions that are shown as bold and underlined.

Rebuild the part.

**4 Close and save.**

Close the bracket part, saving the changes that you have made. Respond **Yes** to rebuilding the assembly.

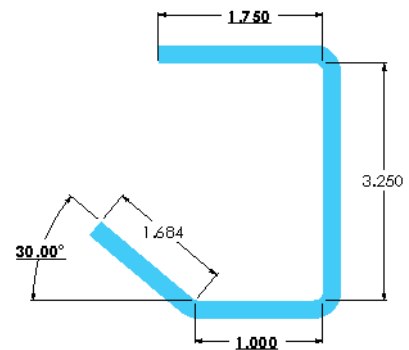

**5 Changes.**

The changes made in the part also appear in the assembly.

**6 Turn the crank.**

The crank should turn freely, turning the two yokes, the spider, and the pins with it.

**7 Delete mate.**

Expand the Mate folder and delete the mate Parallel2.

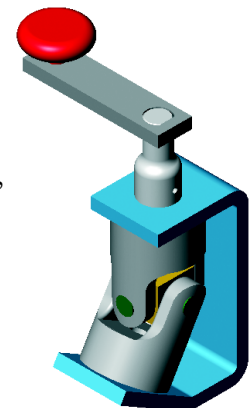

**8 Turn the crank.**

The crank should turn freely but it is no longer connected to the yokes and spider.

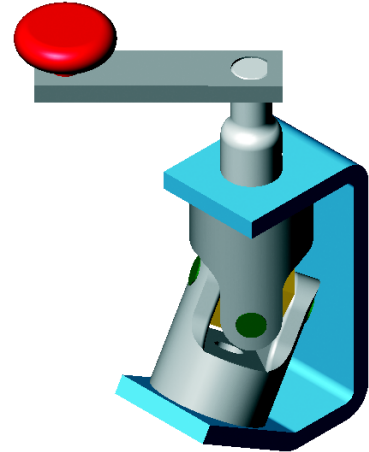

**9 Insert a set screw.**

Insert the existing component named set screw. Mate it to the small hole in the crank-shaft with a **Concentric** mate.

Optionally, click the **Lock Rotation** option.



**10 Hide component.**

Hide the crank-shaft component. Add a **Coincident** mate between the flat faces of the set screw and the Yoke\_Male.

**11 Show component.**

Show the crank-shaft component.

**12 Turn the crank.**

The crank should turn freely and once again, the two yokes, the spider and the pins should rotate with it.

**13 Save and close the assembly.**

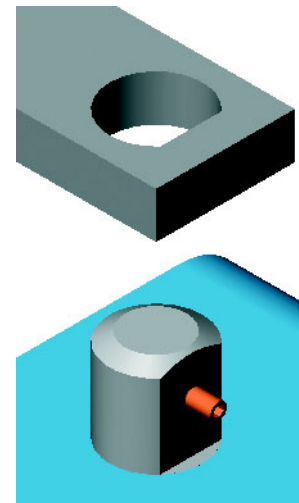

# Lesson 7

## The Analysis Process

### Objectives

Upon successful completion of this lesson, you will be able to:

- Navigate the SOLIDWORKS Simulation user interface.
- Analyze a linear static study using solid elements.
- Understand the influence of mesh density on displacement and stress results.
- Employ various methods to present FEA results.
- Manage SOLIDWORKS Simulation result files.
- Access available help and assistance.

## The Analysis Process

All SOLIDWORKS Simulation studies follow a similar process, regardless of the model or simulated event. This lesson explores the analysis process with a simple example and shows all the fundamental steps required to set up, run and analyze a simulation.

### Stages in the Process

Some key stages in the analysis of a model are shown in the following list:

- **Create a study**  
A study is an analysis performed on a model. A model can contain multiple studies.
- **Apply material**  
Material properties, such as the Elastic Modulus, define a structure's response to a load.
- **Apply fixtures**  
Fixtures represent the way the physical model is held.
- **Apply loads**  
Loads represent the forces on the model.
- **Mesh the model**  
The model is divided into finite elements.
- **Run the study**  
The solver calculates the displacement, strain and stress in the model.
- **Analyze the results**  
The results are interpreted.

### Case Study: Stress in a Plate

Determine the stress in a rectangular plate with a hole in its center while subjected to a tensile load.

View this case study as a means to familiarize yourself with the software's basic functionality.

**Project  
Description**

A rectangular plate with a hole in its center is fixed at one end. A uniformly distributed 110,000 newton load applies tension to the other end.

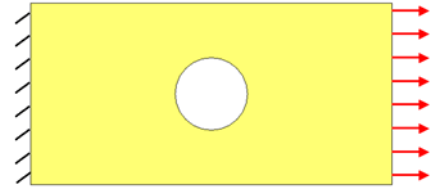

In addition to learning SOLIDWORKS Simulation functions, our objective is to investigate the impact of mesh density on the results. Using FEA terminology, the aim is to examine the effect of different discretization choices on the data of interest; in our case, on deformation and stress. Therefore, we will perform the analyses using meshes with varying element sizes to gain more insight into how FEA works.

---

**14 Open a part file.**

Open rectangular hollow plate from the Lesson01 \Case Studies folder. Review the dimensions of the model and note the length, width, and thickness of the part in millimeters.

**15 Start SOLIDWORKS Simulation.**

From the CommandManager, browse to **SOLIDWORKS Add-Ins**, and click **SOLIDWORKS Simulation**.

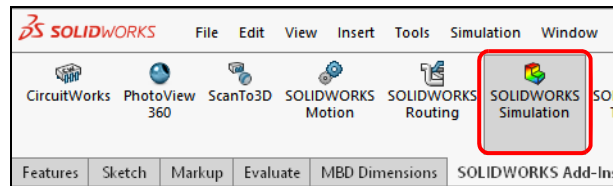

## SOLIDWORKS Simulation Interface

The SOLIDWORKS Simulation user interface is similar to the SOLIDWORKS user interface. As we work, a tree structure records performed steps. Access features using the Simulation Study tree, the Simulation pull-down menu, Toolbars, and the CommandManager.

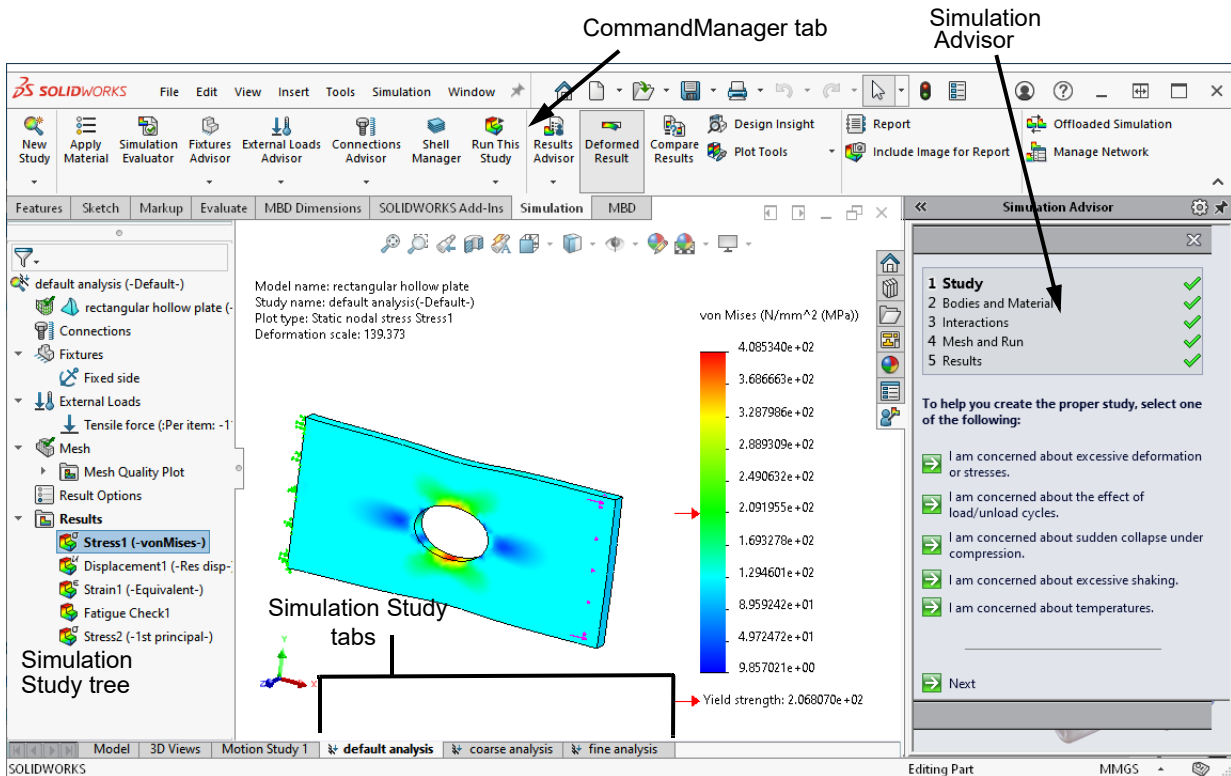

## Simulation Study Tree

Once we create a simulation study, the Simulation Study tree appears over the SOLIDWORKS FeatureManager design tree. Switch between the SOLIDWORKS FeatureManager and the Simulation Study tree using tabs below the graphics area. (The Model tab displays the FeatureManager, and a Simulation Study tab displays its Simulation Study tree.)

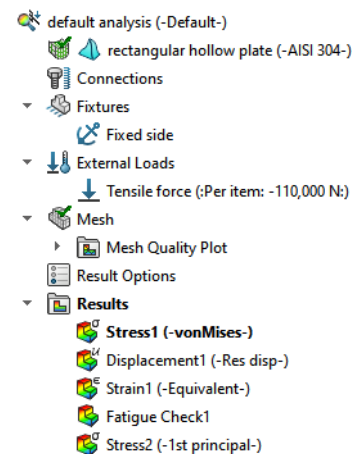

**Simulation Pull-down Menu**

The Simulation pull-down menu provides access many simulation commands.

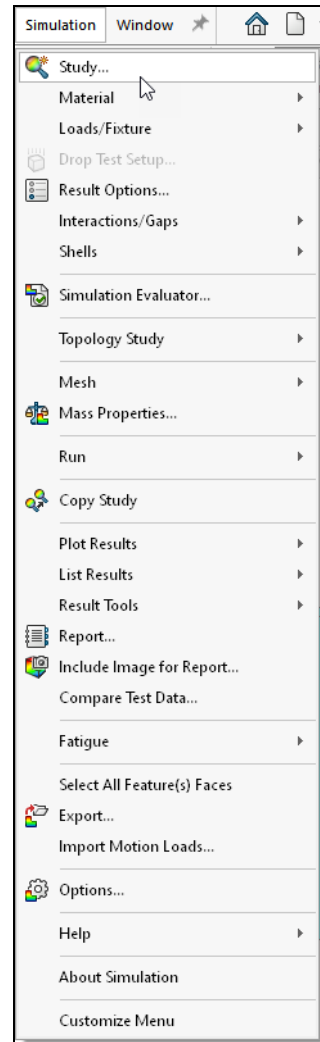

**Toolbars**

The Shortcut toolbar allows you to access commands quickly by clicking the **S** key on the keyboard. Customize the Shortcut toolbar to include the commands you use frequently.

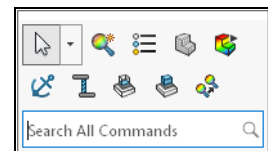

**CommandManager**

The CommandManager provides a universal toolbar for simulation features. The Simulation tab provides the tools to set up a study and analyze results.

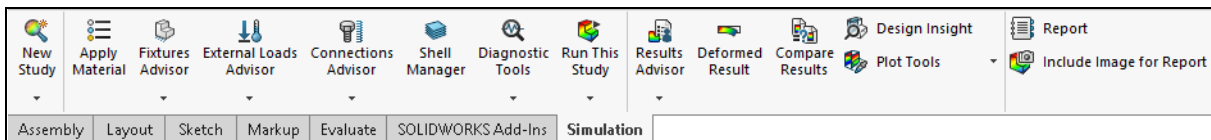

## Context Menus

Right-click geometry and Simulation Study tree items to access relevant features and functions.

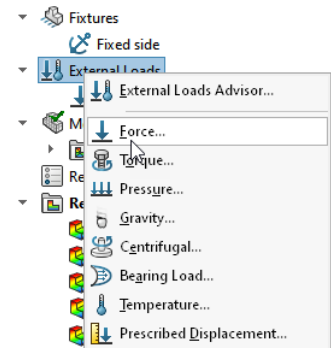

## SOLIDWORKS Simulation Options

The Options on the Simulation pull-down menu enable you to customize the Simulation software to reflect your company's analysis standards. There are two categories of options, system and default.

### ■ System Options

System options apply to all studies. Included are the settings for the way the errors are displayed and the location of the default libraries.

### ■ Default Options

Default options apply to new studies. As we do not use templates for simulation studies, this is where the options are set for units, default plots, etc.

## Where to Find It

- Menu: **Simulation, Options**

### 16 Open Simulation Options window.

Click **Options** .

### 17 Set default units for SOLIDWORKS Simulation.

Under **Default Options**, select **Units**.

Ensure that the **Units system** is set to **SI (MKS)** and **Length/Displacement** and **Stress** are in **mm** and **N/mm<sup>2</sup>(MPa)**, respectively.

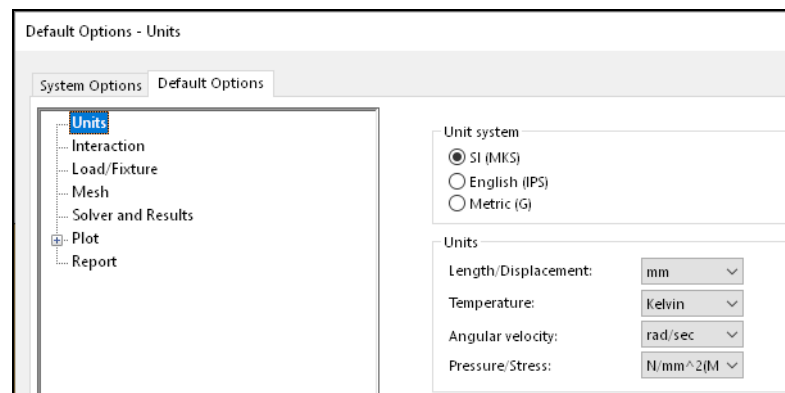

**18 Mesh settings.**

Under **Default Options**, select **Mesh**.

Ensure the option **Mesh all solid bodies with solid mesh** is cleared.

Select the **Curvature-based** Mesher type.

**19 Define the solver and the results folder.**

Click **Solver and Results**.

Under **Default solver**, select **Automatic**.

Under **Save Results**, select **SOLIDWORKS document folder**.

Click **Under sub folder** and enter Results.

**Note**

The SOLIDWORKS document folder is your working directory; it is where the rectangular hollow plate.SLDPRT file resides.

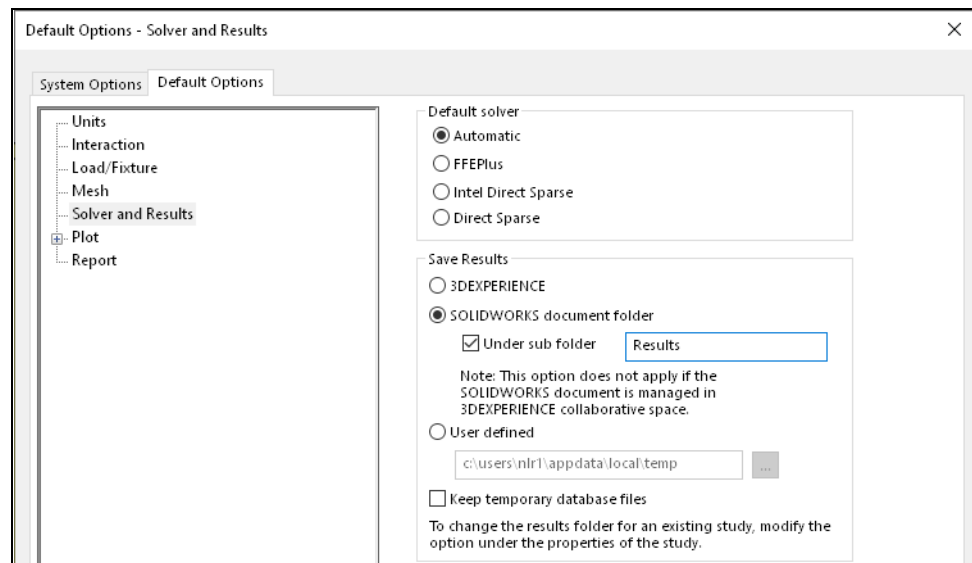

This step directs the software to create a Results folder in the working directory for storing simulation data.

**Plot Settings**

By default, SOLIDWORKS Simulation automatically creates the following result plots after running a study:

- **Stress1**
- **Displacement1**
- **Strain1**

Define new automatically created plots in Default Options, or create plots manually in postprocessing.

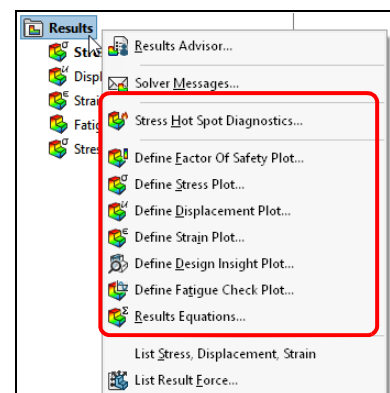

## 20 Set default plots.

Expand the **Default Plots** subfolder located under the **Plot** folder. This section defines the automatically generated result plots that appear in postprocessing.

Explore the **Default Plots** without editing their values.

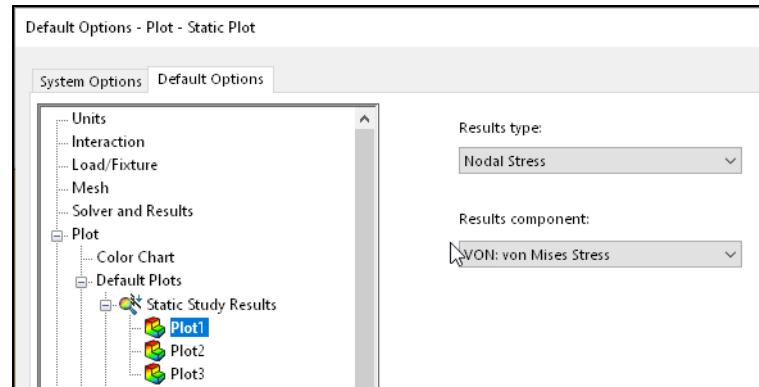

## 21 Specify color chart options.

Under the **Plot** folder, click **Color Chart**.

Set **Number format** to **Scientific** and **No. of decimal places** to **6**.



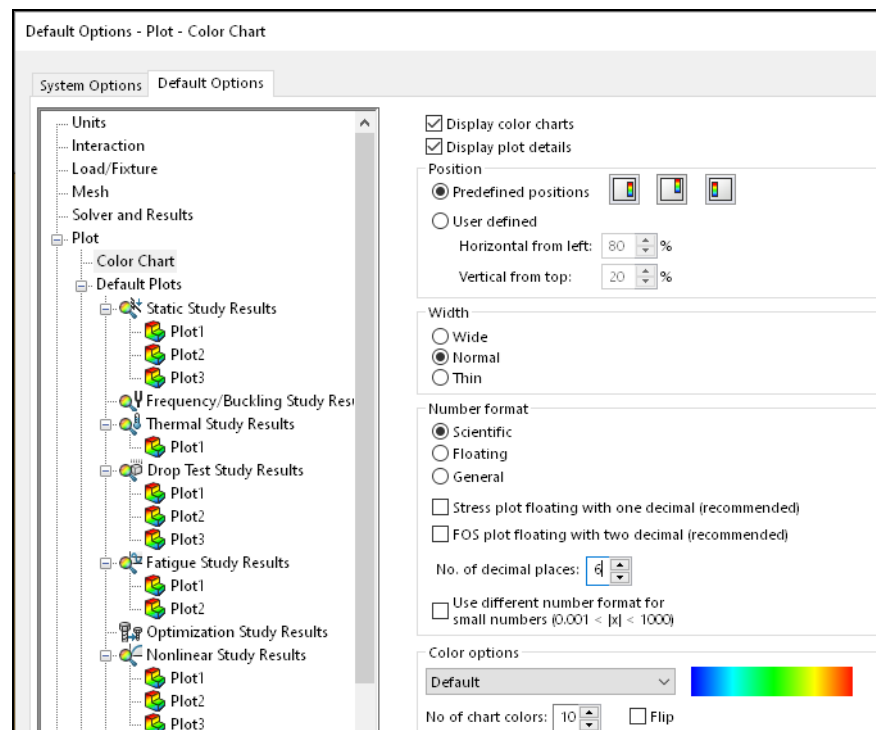

Explore the chart options in this window.

Click **OK** to close the **Options** window.



## Preprocessing

In the following steps, we will prepare the model for analysis. The preprocessing steps include:

- **Create a study** 
- **Apply material** 
- **Apply fixtures** 
- **Apply external forces** 
- **Mesh the model** 



## New Study

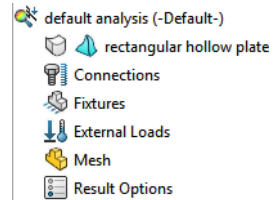

Creating an FEA model always starts with the definition of a study, where we define the type of analysis we wish to perform.



SOLIDWORKS Simulation treats each analysis as a separate study. New studies feature an automatically created tree structure populated with icons. Some icons are folders, or nodes, for storing features. Other icons graphically indicate study information, such as whether or not a step was completed.





Use **Part**  to define and assign material properties,

**External Loads**  to define forces, **Fixtures**  to define restraints, and **Mesh**  to create the finite element model.

**Connections**  define how components interact with one another. In this study, only one component named rectangular hollow plate resides in the **Part**  folder, so we will not use Connections in this lesson.

Studies containing multiple bodies have a **Parts**  folder, containing a **Part**  for each body in the model.

## Where to Find It

- CommandManager: **Simulation > New Study** 
- Menu: **Simulation, Study** 

## Renaming Studies

Change the name of the study by click-pause-clicking on the study name, by clicking the study name and selecting the **F2** button on the keyboard, or by right-clicking on the study tab and selecting **Rename**. (SOLIDWORKS Simulation uses many standard Windows conventions.)

---

### 22 Create a study.

Click **Study** .

### 23 Name the study.

Under **General Simulation** click **Static** .

Type default analysis for the **Name**.

Click **OK** .

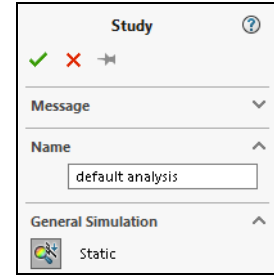

## Assigning Material Properties

SOLIDWORKS Simulation and SOLIDWORKS share a common Material database, which allows you to assign material properties in either environment. - A material assigned in SOLIDWORKS automatically transfers to SOLIDWORKS Simulation when defining a new study.

A material can store mechanical property values, appearance information, and sheet metal bending data. SOLIDWORKS Simulation requires specific mechanical properties, color-coded within the SOLIDWORKS Simulation environment. Material constants displayed with red text are mandatory for all Static studies. Particular situations require the blue constants. (E.g., a Temperature load requires the Thermal Expansion Coefficient).

Add frequently used materials to a Favorites folder. Use Favorites to apply material without opening the material window. To manage the Favorite material list, right-click **Material**  in the SOLIDWORKS FeatureManager design tree and select **Manage Favorites**.

### Where to Find It:

- Menu: **Simulation, Material, Apply Material to All** 
- CommandManager: Select the component in the Simulation Study tree, **Simulation > Apply Material**
- Shortcut Menu: Right-click a body from the tree and click **Apply/Edit Material** (alternatively: **Apply Favorite Material**)

### Note

The first method assigns the same material properties to all components in the model. The second method assigns material properties to the components that were selected. The third method assigns material properties to one particular body.

## 24 Assign material properties.

Click **Apply/Edit Material** .

Expand **SOLIDWORKS Materials** and select **AISI 304** from the **Steel** folder.

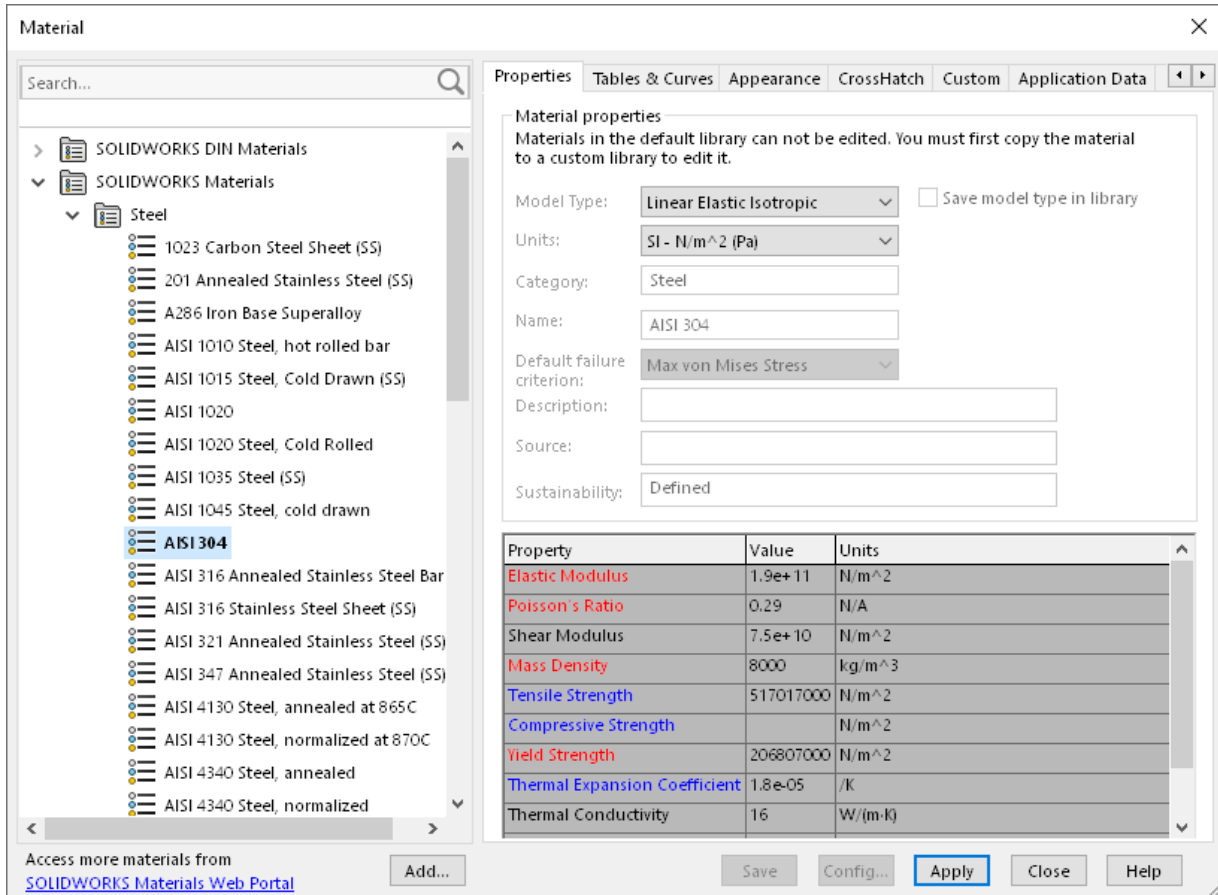

Click **Apply** and **Close**.

The rectangular hollow plate icon in the **Parts** folder now displays a green check mark and the name of the assigned material.







## Fixtures

Restraints allow a structure to maintain stability when subjected to loads. Fixtures represent a connection between the model and the ground (geometry that is not explicitly modeled). SOLIDWORKS Simulation provides various fixtures to restrain the model. Generally, fixtures can be applied to faces, edges and vertices.







## Fixture Types

SOLIDWORKS Simulation groups fixtures into two categories, Standard and Advanced, summarized in the tables below:

### Standard Fixtures

Fixture Type	Definition
<b>Fixed Geometry</b> 	Also called a rigid support, all translational and all rotational degrees of freedom are constrained.
<b>Immovable</b> 	This restraint locks translational movement but allows rotational movement. This option is only available when working with shell and beam elements but not solid elements. (Solid elements can not rotate.)
<b>Roller/Slider</b> 	Use the Roller/Slider restraint to specify that a planar face can move freely in its plane but cannot move in the direction normal to its plane. The face can shrink or expand under loading.
<b>Fixed Hinge</b> 	Use the Hinge restraint to specify that a cylindrical face can move only about its axis. The radius and the length of the cylindrical face remain constant under loading.
<b>Elastic Support</b> 	This fixture defines an elastic foundation between the selected faces of a part or assembly and the ground. The faces do not have to be planar.  An Elastic Support fixture with infinite stiffness behaves the same as the Fixed Geometry fixture.
<b>Bearing Fixture</b> 	This fixture defines a connection between a cylindrical face and the ground with elastic characteristics. A Bearing fixture with infinite stiffness and unconstrained rotation behaves the same as a Fixed Hinge fixture.
<b>Foundation Bolt</b> 	This fixture connects the model to the ground by applying an elastic force to areas around a circular hole on a planar face. Define Foundation Bolts in conjunction with Virtual Walls.

## Advanced Fixtures

Fixture Type	Definition
<b>Symmetry</b> 	This option is available on flat faces and allows the structure to translate and rotate along the selected face.
<b>Cyclic Symmetry</b> 	This option is used to restrain segments which, if periodically revolved around a specified axis of revolution, would form a rotationally symmetrical body.
<b>Use Reference Geometry</b> 	This option restrains a face, edge, or vertex only in desired direction(s), while leaving the other directions free to move. You can specify the desired direction(s) of restraint in relation to the selected reference plane, axis, edge, or face. The SOLIDWORKS Flyout FeatureManager is useful for selecting reference geometry (plane and axis).
<b>On Flat Faces</b> 	This option provides restraints in selected directions, which are defined by the three principal directions of the flat face where restraints are being applied.
<b>On Cylindrical Faces</b> 	This option is similar to <b>On flat face</b> except that the three principal directions of a cylindrical reference face define the directions in a cylindrical coordinate system; this option is very useful because you can apply a restraint that allows for rotation about the axis associated with the cylindrical face.
<b>On Spherical Faces</b> 	Similar to <b>On flat faces</b> and <b>On cylindrical faces</b> ; the three principal directions of a spherical face define the directions of the applied restraints in a spherical coordinate system.

## Where to Find It

- CommandManager: **Simulation > Fixtures Advisor > Fixed Geometry** 
- Menu: **Simulation, Loads/Fixture, Fixtures**
- Shortcut Menu: Right-click **Fixtures** and click **Fixed Geometry**



## Fixture Symbols

After defining a Fixture, fixture symbols appear on affected faces, edges, and vertices.

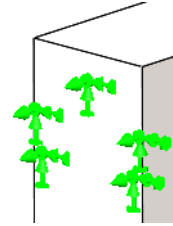
In this case study, we select **Fixed Geometry**  as the fixture type, meaning that all six degrees of freedom (three translations and three rotations) are restrained.



Arrows indicate translational restraint and discs indicate rotational restraint. In this lesson, the fixtures are defined by the directions of the global coordinate system, visible in the lower-left corner of the model window.

If, instead of selecting **Fixed Geometry**  as the type of fixture, we selected **Roller/Slider** , then the rotational degrees of freedom would not be constrained and the corresponding fixture symbols would feature only arrows, not discs.

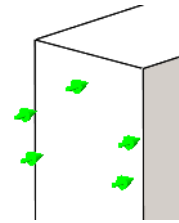

---

## 25 Define Fixed Restraints.

Click **Fixed Geometry** .

Rotate the model and select the face as shown.

Click **OK** .

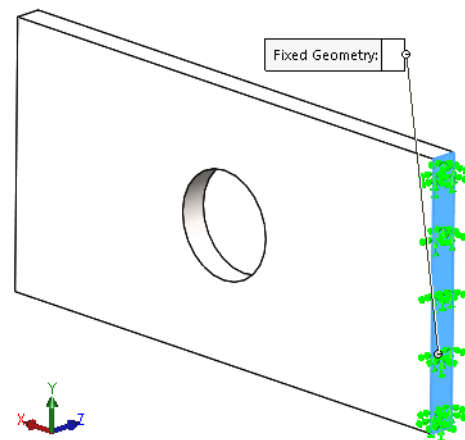
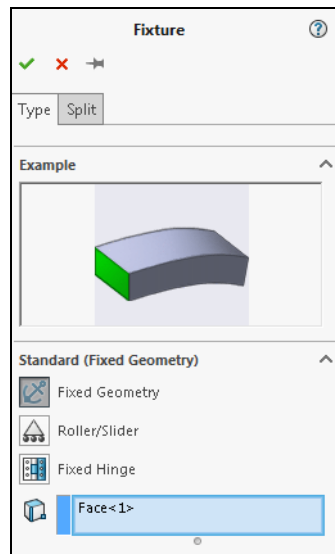

Having defined fixtures, we have fully restrained the model in space. Therefore, the model cannot displace without elastic deformation.

---



**Renaming Folders** Edit feature names within the Simulation tree for fixtures, loads, connectors, and result plots, to organize work and state intent. Use click-pause-click or select the object and use the F2 button on the keyboard to rename an object.

### 26 Rename the fixture.





Rename the fixture named Fixed-1 to Fixed side.

**External Loads** Once the model is restrained, we must apply external loads or forces to the model. Generally, forces are applied to faces, edges, and vertices using various methods. These external forces and their properties are summarized below:



### Standard External Forces

Force Type	Definition
<b>Force</b> 	<p>This option applies a force or moment to a face, edge, or vertex in the direction defined by selected reference geometry (plane, edge, face, or axis).</p> <p>Note that a moment can only be applied if shell or beam elements are used. Shell and beam elements have six degrees of freedom per node (translations and rotations) and can assume a moment load. Solid elements have only three degrees of freedom per node (translations only) and, therefore, cannot assume a moment load directly.</p> <p>If you need to apply a moment to solid elements, it must be represented by appropriately distributed forces, or remote loads.</p>
<b>Torque</b> 	<p>This option applies torque about a reference axis using the Right-hand Rule. This option requires that the axis be defined in SOLIDWORKS.</p>

### Advanced External Forces

Force Type	Definition
<b>Pressure</b> 	<p>Applies a pressure to a face. Can be directional and variable, such as hydrostatic pressure.</p>
<b>Gravity</b> 	<p>Applies linear accelerations to parts or assemblies.</p>
<b>Centrifugal Force</b> 	<p>Applies an angular velocity and acceleration to a part or assembly.</p>
<b>Bearing Load</b> 	<p>Bearing loads are defined between interacting cylindrical faces.</p>

## Advanced External Forces

Force Type	Definition
<b>Remote Load/ Mass</b> 	Remote loads apply loads that would normally be transferred by connecting structure.
<b>Distributed Mass</b> 	Distributed masses are applied to selected faces to simulate the mass of components that are suppressed or not included in the model.
<b>Temperature</b> 	Temperatures are applied to components for thermal expansion effects.

### Where to Find It

- CommandManager: **Simulation > External Loads Advisor >** click one of the available **Force Types**
- Menu: **Simulation, Loads/Fixture**, click one of the available **Force Types**
- Shortcut Menu: Right-click **External Loads** and click one of the available **Force Types**

### Note

The presence of an external force is indicated by arrows symbolizing the load and by the corresponding icon.

**27 Define Force.**

We will apply a tensile force of 110,000 N [24,729 lbf] to the face opposite the fixture.

Rotate the model's orientation to view the face opposite the fixture.

Click **Force** ↓.

Click the face opposite the fixture.

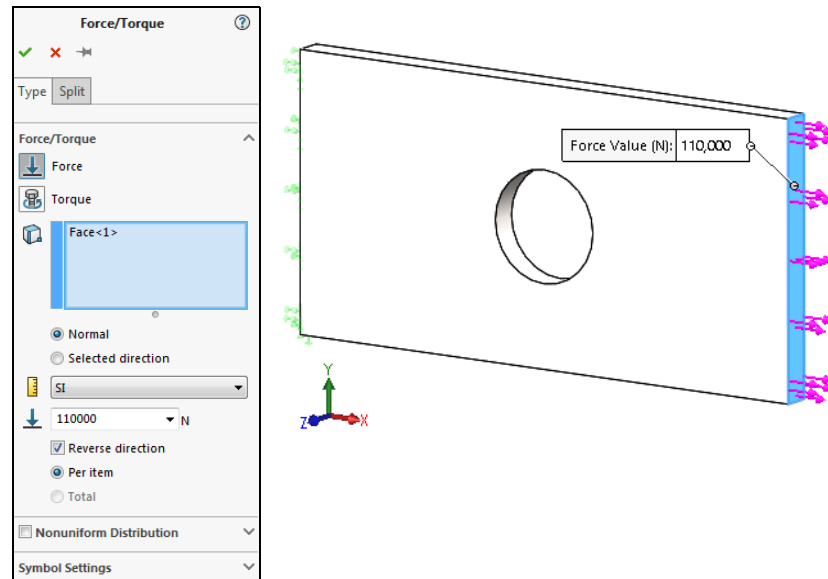

Select **Normal** to specify that the force acts normal to the selected face. In the **Units** dialog ensure **SI** is selected and in the **Force Value** box, type 110,000.

Select **Reverse direction**. (This is required to define a tensile force.)

When defining a normal force we do not need to use any reference geometry. Load direction is sufficiently defined by the orientation of the loaded face with Normal selected.

Click **OK** ✓.

**28 Rename the force.**

Rename the force created in the previous step to Tensile force.

## Size and Color of Symbols

The size and color of restraint and load symbols can be controlled both locally and globally.

The local settings of the symbols are controlled from the Symbol settings dialog in the Fixtures and External Loads PropertyManagers.

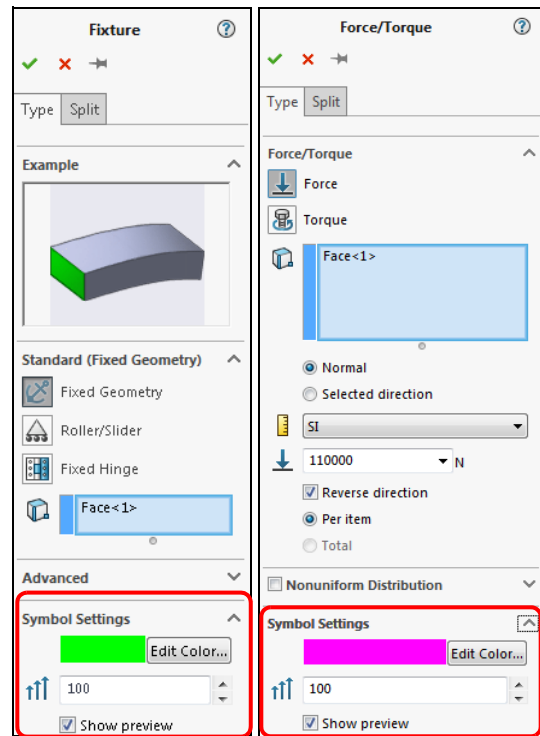

The global definitions for the symbols are controlled by the SOLIDWORKS Simulation Options in the Load/Fixture folder.

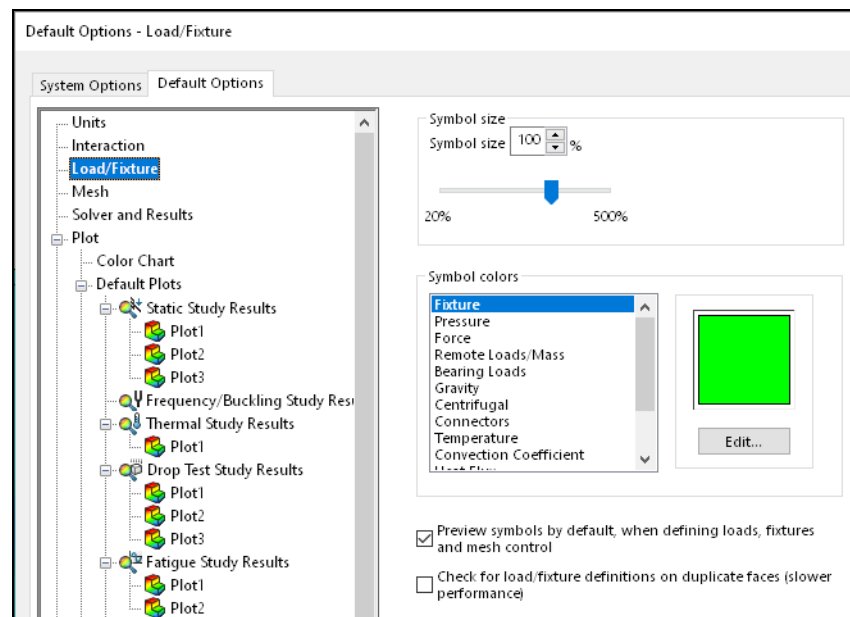

## Display/Hide Symbols

The model now shows both load and restraint symbols. To hide or show the symbols:

- Right-click a particular restraint or load icon in the Fixtures or External Loads folder and choose **Show** or **Hide**.
- Right-click the Fixtures or External Loads folder to globally display or hide loads and restraints and choose **Show All** or **Hide All**.

## Preprocessing Summary

Now that we have assigned material properties, fixtures, and external loads, we have fully defined the mathematical model, which we will discretize into a finite element model (mesh) before solving. Let us make a few observations about the following terms:

- Geometry preparation
- Material properties
- External loads definition
- Fixtures definition

## Geometry Preparation

Geometry preparation is a well-defined step with few uncertainties. Geometry that is simplified for analysis can be checked visually by comparing it with the original CAD model.

## Material Properties

Material properties are most often selected from the material library and do not account for local defects, surface conditions, and so on. Generally, material definition has more uncertainties than geometry preparation.

## External Loads Definition

Defining external loads involves many background assumptions because in real life, the load magnitude, distribution, and time dependence are often approximated and must be roughly estimated in FEA with many simplifying assumptions. Therefore, significant idealization errors can be made when defining loads. Nonetheless, loads can be expressed in numbers, which makes loads easier for FEA users to relate to.

## Fixtures Definition

Defining restraints is where severe errors are most often made. A common error is over-constraining the model, which results in an overly stiff structure that underestimates deformations and stresses.

The relative level of uncertainties in defining geometry, material, loads, and fixtures is qualitatively shown.

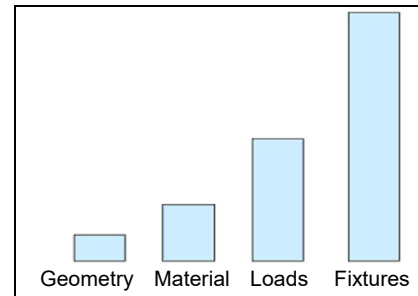

## Idealizations and Assumptions

Geometry is the easiest to define, while fixtures are the most difficult, but the difficulty level has no relation to the time required for each step, so the message in this bar graph may be counterintuitive. Preparing CAD geometry for FEA may take hours while defining material, and applying loads and fixtures involves only a few mouse clicks.

In all examples here, we assume we know the material properties, external forces, and supports with certainty, and the way we define the model represents an acceptable idealization of real conditions. However, we need to emphasize that it is the software operator's responsibility to determine if all those idealized assumptions made during the creation of the mathematical model are indeed acceptable. The best automeshers and the fastest solvers do not help if the mathematical model submitted for FEA analysis is based on erroneous assumptions.

## Meshing

The last step before processing the FEA model is to mesh the geometry. In this step, the geometry will be divided into finite elements by an automatic mesher. While the automatic mesher will take care of the tedious part of the problem, we have input into the process to control the size and quality of the mesh.

### Standard Mesh

This mesh type was the first developed for SOLIDWORKS Simulation and makes use of Voronoi-Delaunay meshing scheme. However, when representing small features and curved geometries the mesh can experience large aspect ratios or failure. When a symmetrical mesh is required, this mesh type is ideal.

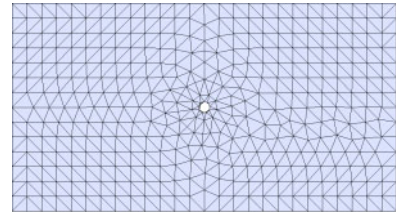

### Curvature-Based Mesh

The Curvature-based mesh algorithm generates a mesh with a variable element size that allows the accurate resolution of small features in the geometry. The curvature based mesher supports multi-threading. This mesh can result in large aspect ratios.

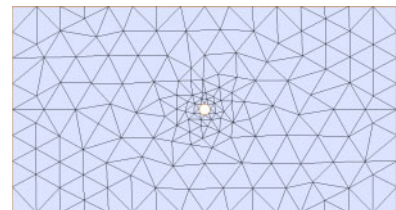

### Blended Curvature-Based Mesh

Models which produce large aspect ratios or failure from the curvature based mesher can often be resolved with this mesher. This mesher supports multi-threading but does not support adaptive mesh refinement.

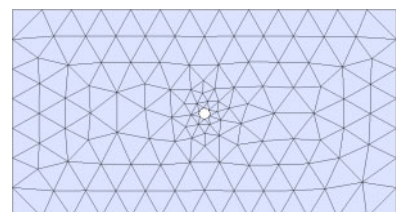

**Mesh Density**

Mesh density directly affects the accuracy of results. A mesh consisting of small elements will provide results with lower discretization errors, but this comes at the cost of increased mesh creation and solving times.

**Element Sizes**

Elements are often irregular. For simplification, we define the size of an element by its characteristic length, which is the diameter of a sphere circumscribing the element (on the left in the following figure). This representation is easier to illustrate with the 2-D analogy of a circle circumscribing a triangle (on the right in the following figure).

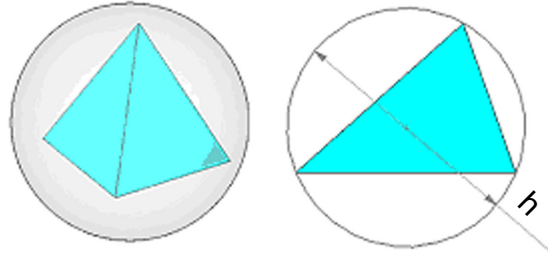

Because the Curvature-based mesh algorithm generates a mesh with a variable element size, the **Maximum element size** and **Minimum element size** define how big and small the elements are. These parameters are established automatically, based on the geometric features of the SOLIDWORKS model.

SOLIDWORKS Simulation uses the units of length specified in the SOLIDWORKS model for the element size. Remember, however, that we can enter analysis data and analyze results in any one of three unit systems: SI, Metric and English.

**Minimum Number of Elements in a Circle**

The **Min number of elements in a circle** parameter defines how the small features in the geometry will be resolved. For example, if the model had a hole, the number of elements in a circle will define how many elements will surround that circle. In the image to the right, we have defined a minimum of 10 elements to surround the hole.

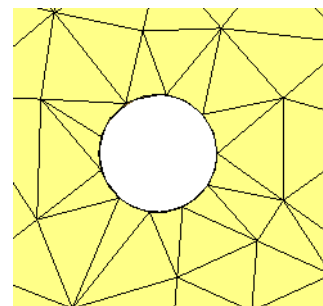

## Ratio

The ratio defines the transition of the mesh from the **Minimum element size** to the **Maximum element size**.

The **Ratio** parameter specifies the ratio between element sizes in consecutive transitional element layers.

The following shows the use of this option.

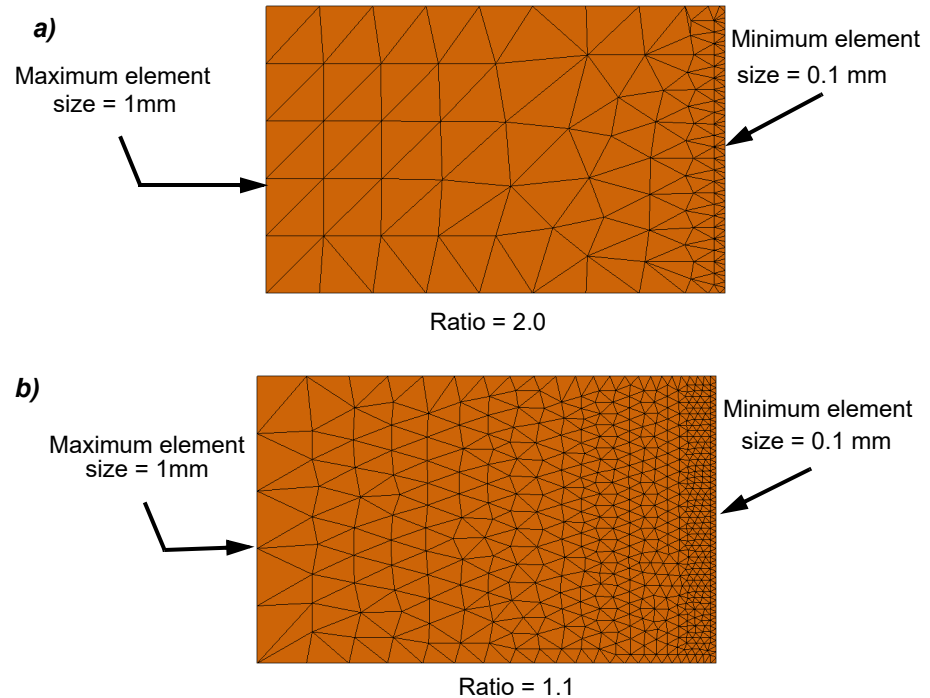

## Tip

In the majority of analyses with SOLIDWORKS Simulation, the default mesh settings produce a mesh that provides acceptable discretization errors while keeping solution times reasonably short.

## Where to Find It

- CommandManager: **Simulation > Run This Study > Create Mesh** 
- Menu: **Simulation, Mesh, Create**
- Shortcut Menu: Right-click **Mesh** and click **Create Mesh**

---

### 29 Generate the mesh.

Click **Create Mesh** .

**30 Set the mesh properties.**

Expand all the sections within the PropertyManager.

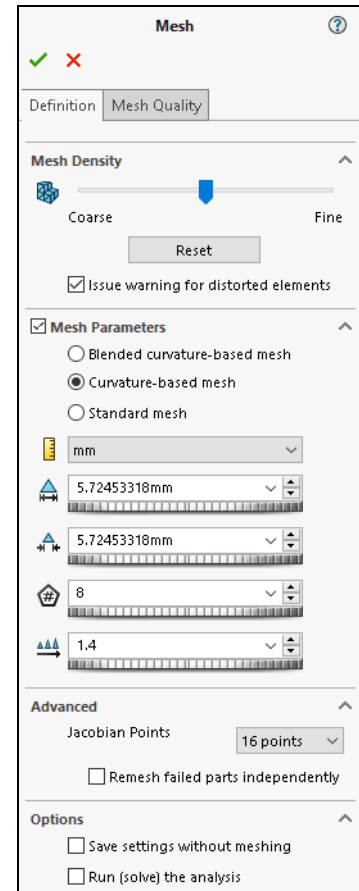

The slider in the **Mesh Density** section controls the **Maximum element size** and the **Minimum element size**. The slider always starts in the center by default, but the geometry determines the default element size values.

For this analysis, keep all default settings.



**Mesh Quality**

Two element types exist in SOLIDWORKS Simulation; first-order (Draft) and second-order (High quality). Each body within an analysis is assigned an element type, with High quality being the default specification.

There are two ways to assign element types to bodies - through the Simulation tree, and the Mesh dialogue.

The Simulation tree provides insights into the element type assigned to bodies. A curvy edge tetrahedral  indicates High quality elements, while a straight edge tetrahedral  indicates Draft quality.

**Where to Find It**

- Shortcut Menu: Right-click a body and click **Apply Draft Quality Mesh**  or **Apply High Quality Mesh** 
- Within the **Mesh** command: Click the Mesh Quality tab

### 31 Set mesh quality.

Click the **Mesh Quality** tab.

The rectangular hollow plate body is specified as **High Quality** .

Click **OK**  to generate the mesh.

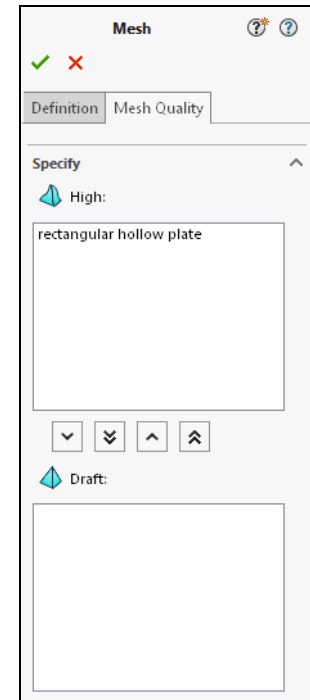
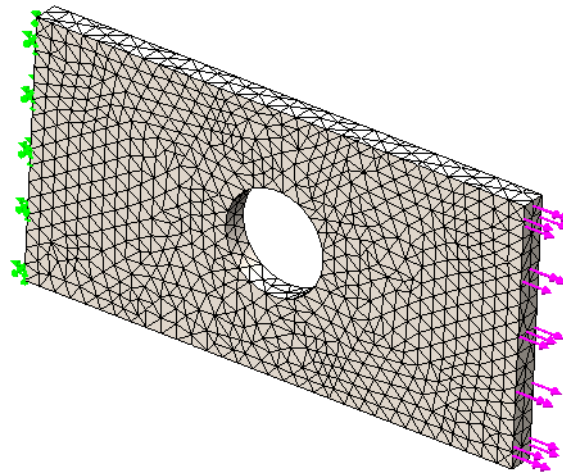

Icons in the SOLIDWORKS Simulation Study tree display a green checkmark to indicate a successfully created mesh.

#### Note

We named this study default analysis with the intention of using the default mesh size. Later in this lesson, we solve the same model with a coarse and fine mesh.

#### Display/Hide Mesh

The Create Mesh command automatically generates a Mesh Quality Plot, which displays the mesh on the screen. Hide or show this plot to toggle the mesh visibility.

#### Where to Find It

- Shortcut Menu: **Mesh, Mesh Quality Plot**, Right-click **Quality1** and click **Hide** or **Show**

## Processing

Once the preprocessing operations are complete, the study is ready to run. This stage is known as “processing.” In the processing stage, matrices are obtained from the preprocessing operations that describe the structure’s stiffness and loads. These matrices are then combined to obtain the response of the structure. The response of the structure is what is then analyzed in the postprocessing stage of the analysis.

### Where to Find It

- CommandManager: **Simulation > Run This Study >**

#### Run This Study

- Menu: **Simulation, Run, Run**
- Shortcut Menu: Right-click on the study name and click **Run**

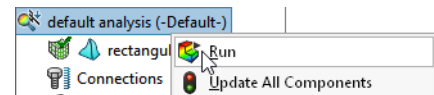

### 32 Run the analysis.

Click **Run** .

You can monitor or pause the solution in the solver window while the analysis is running.

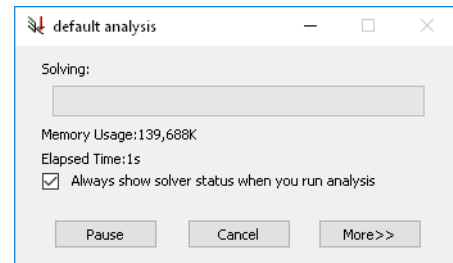

## Postprocessing

Once processing completes, SOLIDWORKS Simulation automatically creates a Results folder containing the Default Plots (as defined in the Default Options in step 20 on page 268) that you can view or modify. You can also create new Result Plots or list values, such as the force or pressure acting on a face.

### Result Plots

A Result Plot is a color-coded plot overlaid on top of the model's geometry, indicating its response to the applied load.

There are two ways to view an existing plot:

- Double-click the desired plot (Stress1, for example).
- Right-click the desired plot (Stress1, for example) and select **Show**.

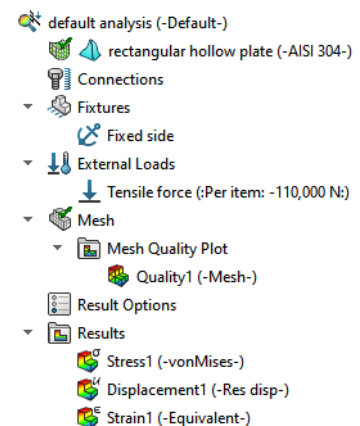

<b>Stress Plots</b>	Analyze directional stress components and combined stress values (such as the von Mises stress) with Stress Plots.
<b>Displacement Plots</b>	Analyze the directional components of displacement and total displacement with Displacement Plots.
<b>Strain Plots</b>	Analyze strain to understand a structure's response to load with Strain Plots.

---

---

### 33 Show and edit **Stress 1**.

Activate **Stress1** under **Results**.

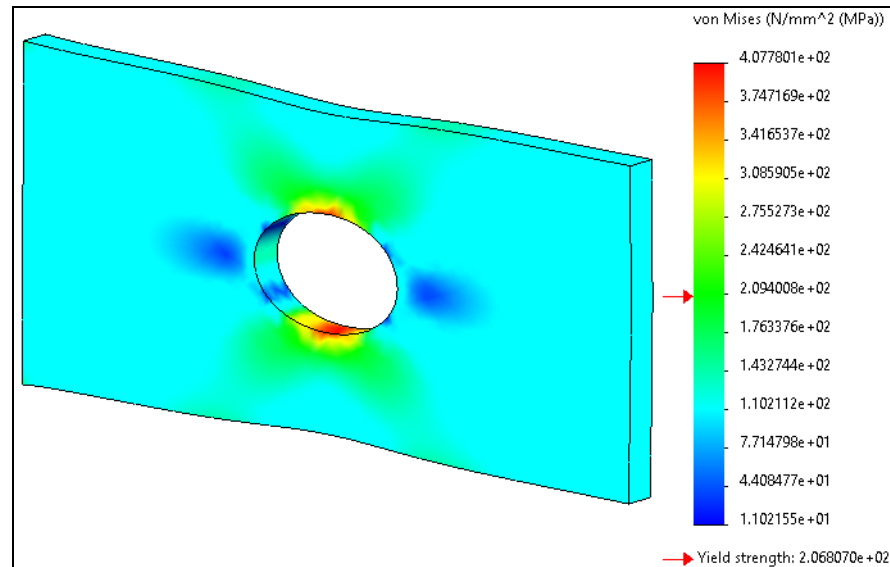

Observe the maximum value of Von Mises stress is 408 MPa, which significantly exceeds the yield stress of the material, 206 MPa, indicated by the red arrow in the chart.

---

---

### Modifying Result Plots

All Result plots are customizable and share a common PropertyManager structure. The Definition, Chart Options and Settings provide options for controlling a plot's content, units, display and annotations.

#### ■ Definition

A plot's Definition controls its most significant attributes, including the plotted Component, Units and Deformation scale. For example, you can edit the Definition of a stress plot and change the Component to display principal stress instead of the von Mises stress.

#### ■ Chart Options

Chart Options control a plot's annotations, colors, legend, and how the units display (scientific, floating, general).

- **Settings**

The Settings control a plot's style and allow you to add plot overlays.

### Where to Find It

- Shortcut Menu: Right-click a plot and select either

**Edit Definition** , **Chart Options**  or **Settings** 

### Nodal vs. Element Stresses

Stress and strain plots allow you to toggle between node and element values when editing the Definition. The following figures show the nodal and elemental values of the von Mises stress in our model.

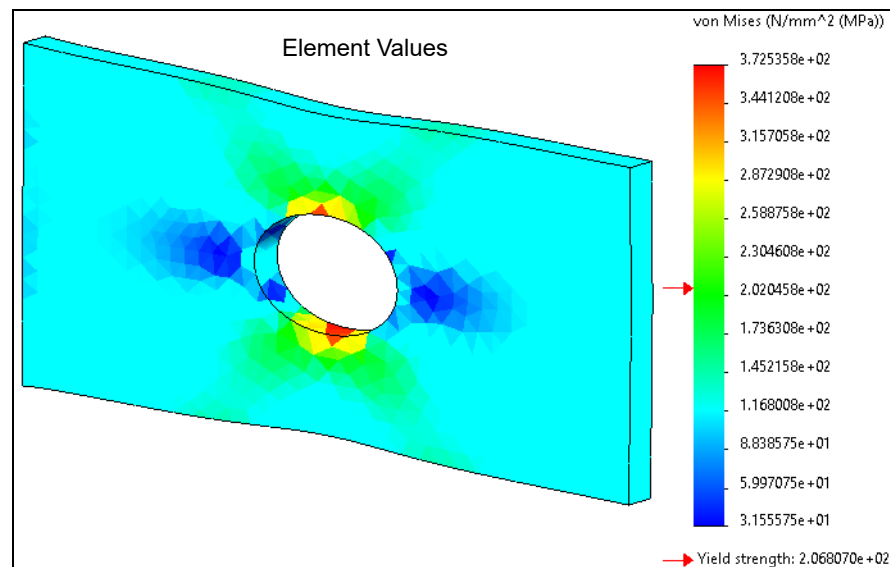
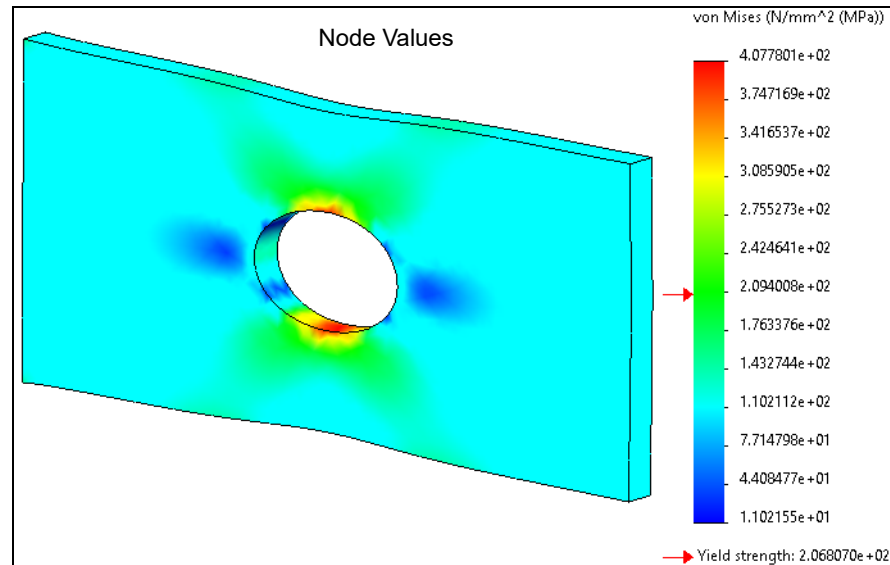

The stress plot that displays **Nodal values** appears “smooth,” while the stress plot that displays **Element values** appears “rough.”

To understand the reasons for these different appearances, we need to explain the differences between nodal and element stresses.

During the solution process, in each element, stress results are calculated at certain locations called Gauss points. First order tetrahedral elements (draft quality) have one Gauss point in their volume. Second order tetrahedral elements have four Gauss points. First order shell elements have one Gauss point. Second order shell elements have three Gauss points.

### Nodal Values

Stresses in Gauss points can be extrapolated to element nodes. Most often, one node is shared by several elements, and each element reports different stresses at the shared node. Reported values from all adjacent elements are then averaged to obtain a single value. This method of stress averaging produces averaged (or nodal) stress results.

- Mesh nodes
- Gaussian points

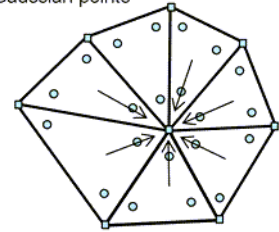

### Element Values

Alternately, the stress values from all Gauss points within each element can be averaged to report a single elemental stress. Although these stresses are averaged between Gauss points, they are called non-averaged stresses (or element stresses) because the averaging is done internally within the same element only.

Element stresses and nodal stresses are always different, but too large a difference indicates that the mesh is not sufficiently refined in that location. See the exercise *Exercise 30: Bracket* on page 309 for the practical use of these quantities.

### Show as Tensor Plot Option

Edit the Definition of a stress plot and click Show as tensor plot to visualize the directions and magnitudes of the principal stress components, P1, P2, and P3. Due to the differences in magnitudes between these stress values, one must zoom in considerably to see all three arrows.

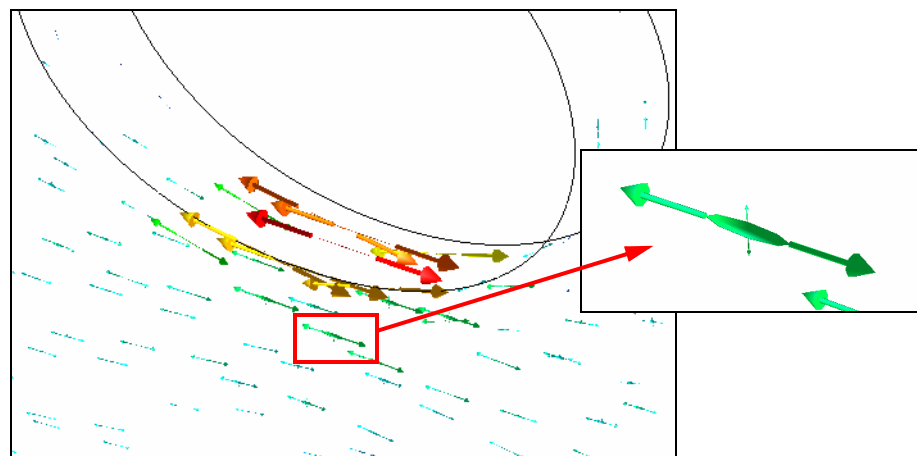

**Average stresses at mid-nodes**

This stress averaging method improves the calculation of stresses at mid-side nodes for High-quality tetrahedral elements with high aspect ratios.

**34 Edit the Definition.**

Right-click Stress1 and select **Edit Definition** .

Select **Average stresses at mid-nodes** under **Advanced Options**.

Click **OK** .

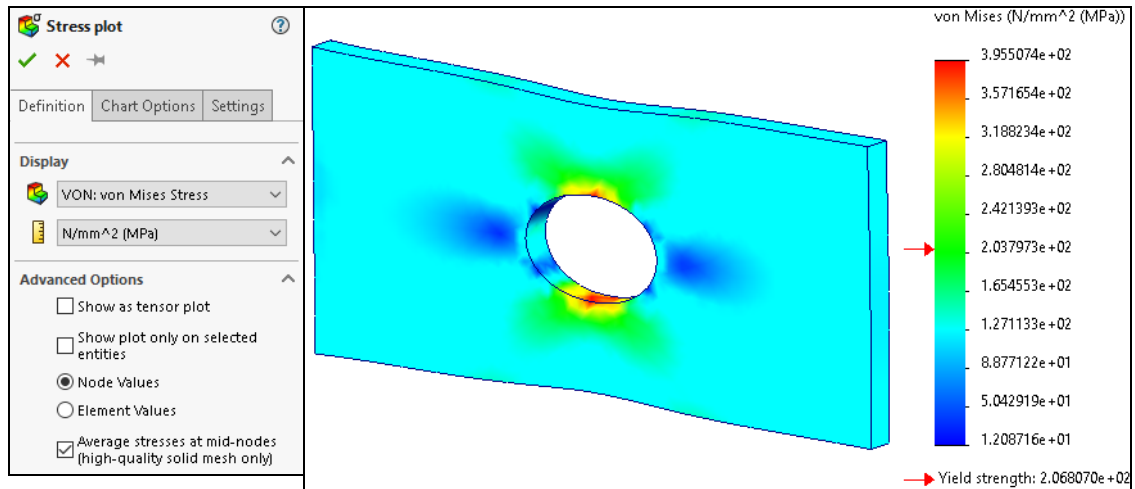

The stress values change slightly (3%).

**Note**

A mesh may require further refinement to obtain accurate results if the option Average stresses at mid-nodes significantly alters observed stress values.

**35 Modify the plot settings.**

Right-click Stress1 and select **Settings** .

Under **Boundary Options**, select **Mesh**.

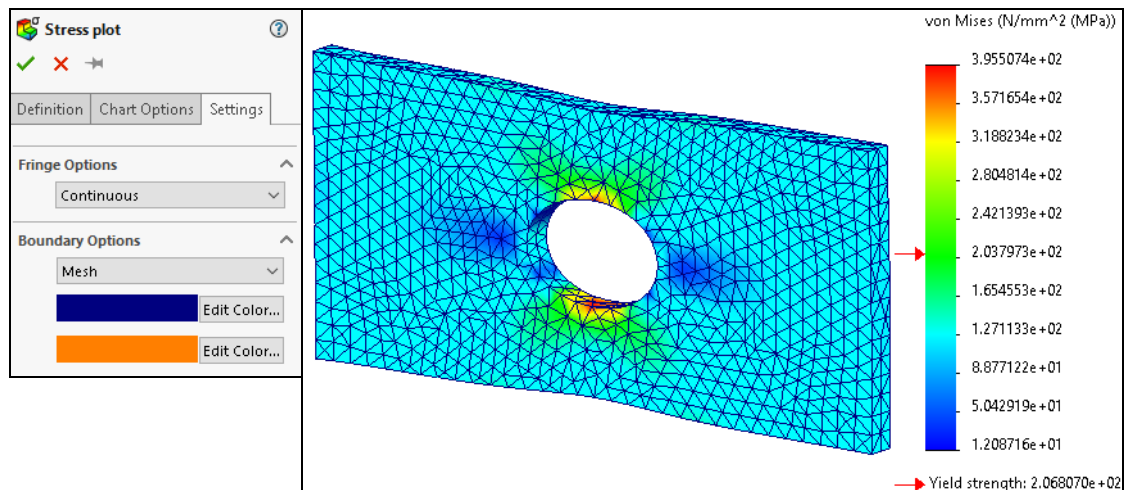

**Tip**

Use the Definition, Chart Options, and Settings tabs within the PropertyManager to save time modifying result plots.

**36 Modify the chart options to highlight yield points.**

Click the **Chart Options** tab.

Check **Show min annotation** and **Show max annotation** to display annotations pointing to the model's highest and lowest stress points.

Clear **Automatically defined maximum value** and enter 206.8 MPa, which is the yield stress limit for AISI 304.

Click **Specify color for values above maximum value**.

Click the **Dropper** . Specify a black color to represent stress values over 206.8 MPa.

Click **OK** .

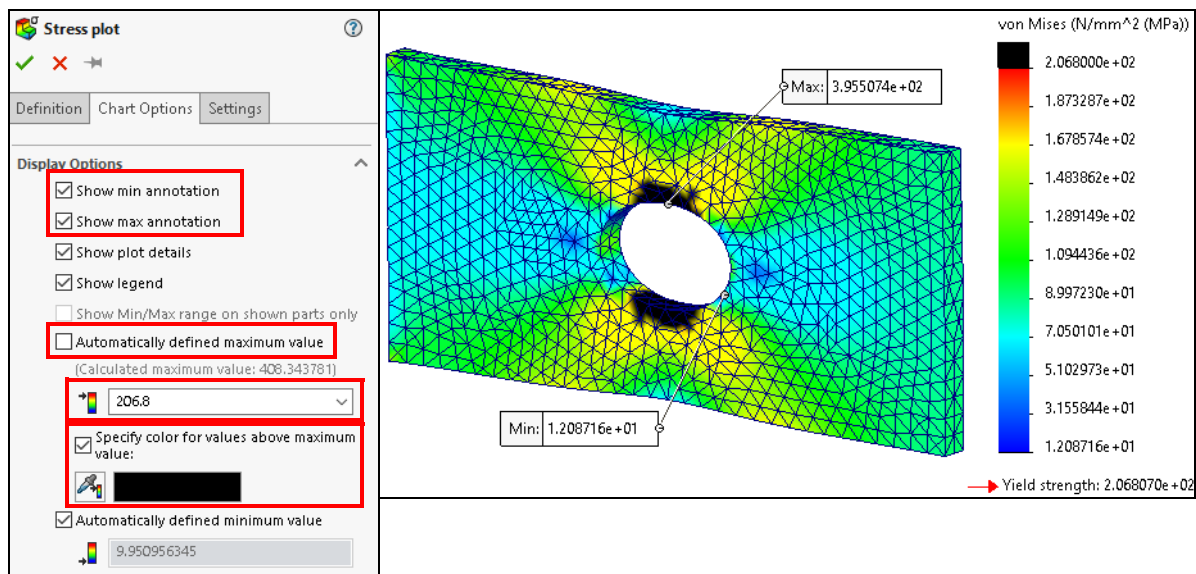

**Note**

Black regions indicate where stress exceeds the yield point.

**37 Rename plot.**

Rename the Result plot Stress1 to Yield.

**38 View displacement plot.**

Activate Displacement1 under **Results**.

The plot shows a maximum resultant displacement of 0.1435 mm.

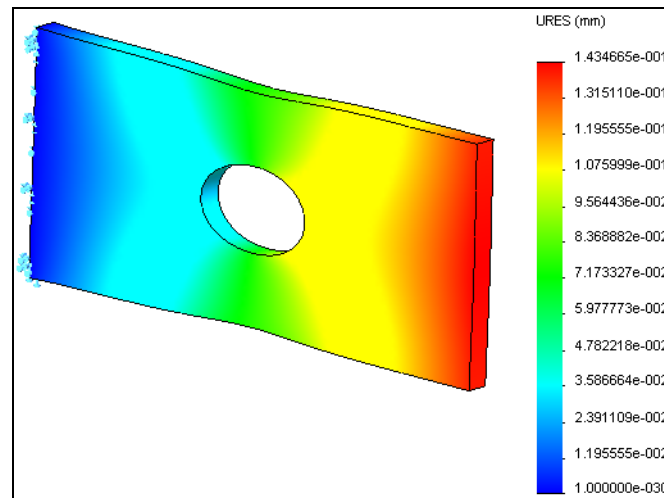

**39 Animate displacement plot.**

Right-click Displacement1 and select **Animate** ▶.

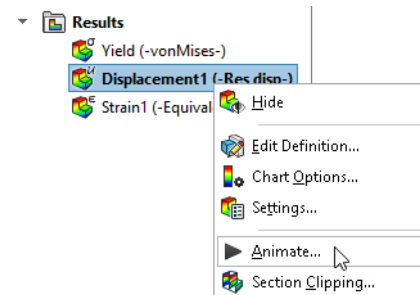

In the **Animation** PropertyManager you can start and stop the animation, set the number of frames, control the speed, and save the animation as an \*.avi file.

Explore the **Animation** command options.

Click **OK** ✓.

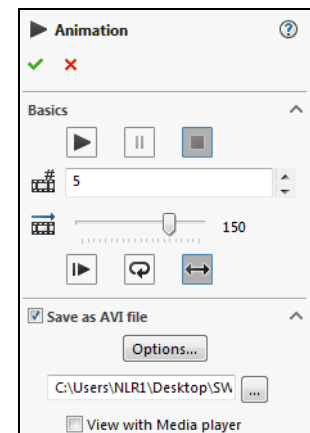

**40 Superimpose undeformed shape.**

Access **Settings** ⚙️ for Displacement1.

Select **Superimpose model on the deformed shape**.

Use the **Transparency** slider and find a value that allows you to see the deformed and undeformed states.

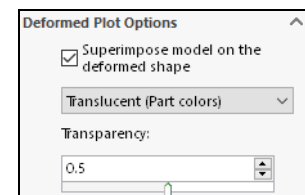

#### 41 Display the true scale.

The plot visually exaggerates the shape by default because deformations are typically small in static studies.

Click the Definition tab.

Click **True scale** under **Deformed shape**.

Click **OK** ✓.

Zoom in on the model to observe the displacement with an accurate perspective.

#### 42 Plot strain results.

Activate Strain1 under **Results**.

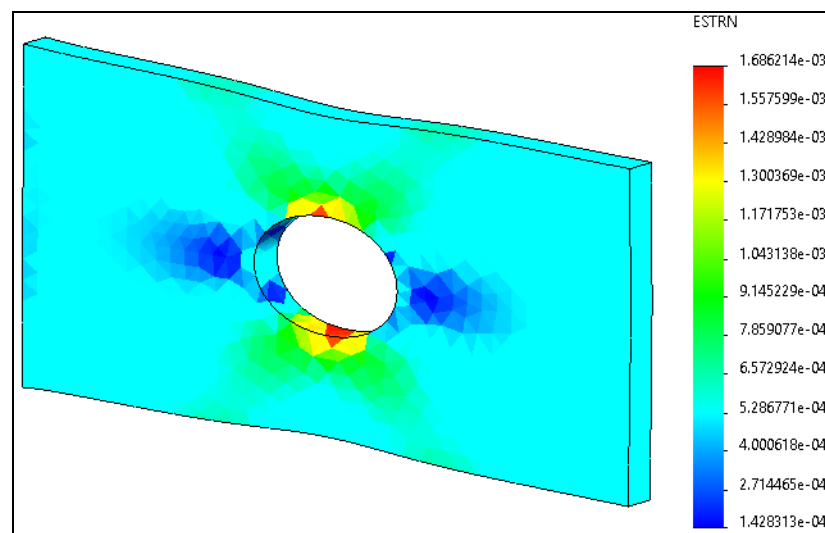

Strain values are dimensionless and provide an intermediate step for validating results.



#### Note

Strain results display with element values by default as opposed to stress results, which display with node values by default.

**Managing Result Plots**

SOLIDWORKS Simulation allows you to add and delete Result plots. Create additional Stress, Strain, and Displacement Plots to highlight areas of interest.

**Where to Find It:  
Add Plots**

- Shortcut Menu: Right-click the **Results** folder and select **Define Stress Plot** , **Define Displacement Plot**  or **Define Strain Plot** 
- CommandManager: **Simulation > Results Advisor > New Plot > Stress, Displacement or Strain**

**Where to Find It:  
Delete Plots**

- Right-click a **Result** plot and click **Delete** 
- Select a plot and click the Delete key from the keyboard

**Additional Plot Controls**

There are several other plot types available to display analysis results.

**Section Plot**

Use Section Plots to position one or more cutting planes through the model to examine interior results.

**Where to Find It**

- Menu: **Simulation, Result Tools, Section Clipping** 
- Shortcut Menu: Right-click an existing plot and select **Section Clipping**

**Iso Plots**

Use Iso Plots to show model regions above or below a specified result value.

**Where to Find It**

- Menu: **Simulation, Result Tools, Iso Clipping** 
- Shortcut Menu: Right-click an existing plot and select **Iso Clipping**

**Probe**

Use the Probe tool to select one or more points on a model to display result and location data.

**Where to Find It**

- Menu: **Simulation, Result Tools, Probe** 
- Shortcut Menu: Right-click a plot and select **Probe**

**43 New stress plot.**

Let's define a new von Mises stress plot with default values to explore the additional plot tools.

Click **Define Stress Plot** .

Accept the default parameters and click **OK** .

#### 44 Create section plot.

Click **Section Clipping** .

From the SOLIDWORKS fly-out menu, select the **Right** plane as the **Reference entity**.

Drag the triad to move the cut plane through the model.

Use **Reverse Clipping Direction**  to control the cutting direction.

Explore options and parameters in the **Section** dialog.

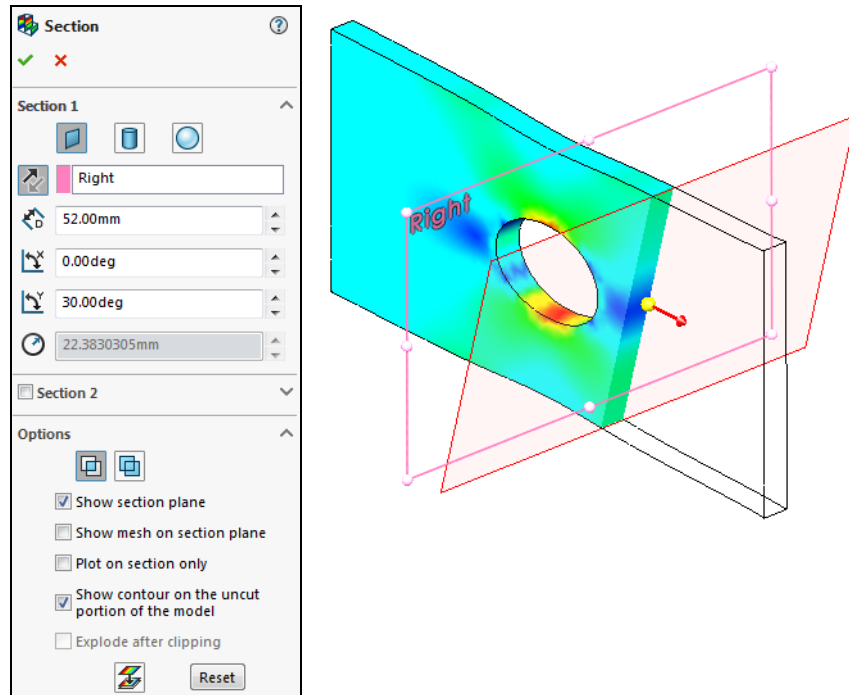

Click **Clipping On/Off**  to disable the section plot.

Click **OK**  to close the **Section** dialog.

#### Important!

If you click **OK** without disabling the section plot, it will remain displayed. To turn it off, reopen the **Section Clipping** command, toggle **Clipping On/Off**, and click **OK**.

**45 Create Iso plot.**

Let's define an Iso Plot to display portions of the model where the von Mises stress is between 170 MPa and 275 MPa.

Click **Iso Clipping** .

Enter 275 N/mm<sup>2</sup> [MPa] under **Iso value**.

Check **Iso 2** and enter 170 N/mm<sup>2</sup> [MPa] for the second **Iso value**.

Experiment with **Reverse Clipping Direction**  under **Iso 1** and **Iso 2** to match the plot below.

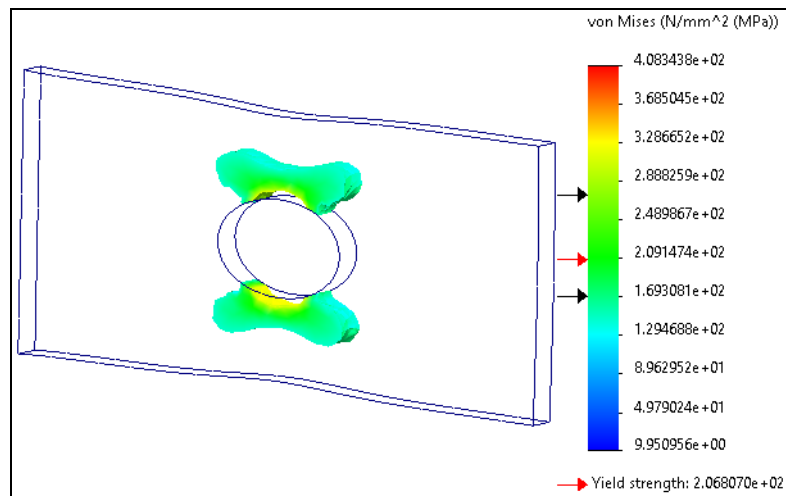

The black arrows on the legend indicate the Iso values.

Click **Clipping On/Off**  to disable the plot.

Click **OK**  to close the **Iso Clipping** dialog.

## 46 Probe stress results.

Click **Probe** .

Use the cursor to select plot locations, as shown in the image below.  
(Change the View Orientation as needed.)

The stress results display in a table under **Results** and annotations at selection points.

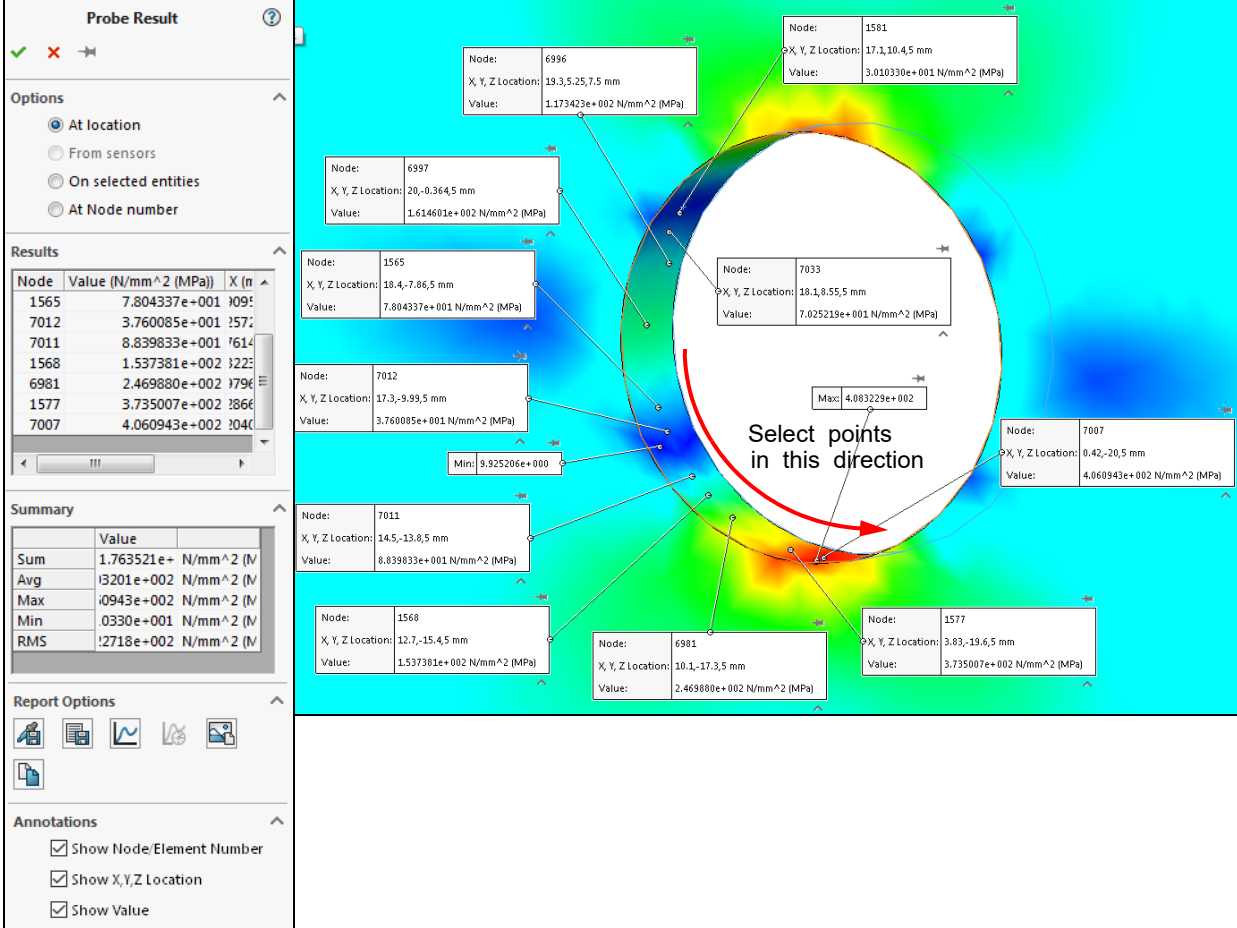

**Probe Result**

Options

- At location
- From sensors
- On selected entities
- At Node number

**Results**

Node	Value (N/mm <sup>2</sup> (MPa))	X (m)	Y (m)	Z (m)
1565	7.804337e+001	18.4	-7.865	0
7012	3.760085e+001	17.3	-9.995	0
7011	8.839833e+001	14.5	-13.85	0
1568	1.537381e+002	12.7	-15.45	0
6981	2.469880e+002	10.1	-17.35	0
1577	3.735007e+002	3.83	-19.65	0
7007	4.060943e+002	0.42	-20.5	0

**Summary**

	Value
Sum	1.763521e+ N/mm <sup>2</sup> (N/mm <sup>2</sup> )
Avg	13201e+002 N/mm <sup>2</sup> (N/mm <sup>2</sup> )
Max	0943e+002 N/mm <sup>2</sup> (N/mm <sup>2</sup> )
Min	0330e+001 N/mm <sup>2</sup> (N/mm <sup>2</sup> )
RMS	12718e+002 N/mm <sup>2</sup> (N/mm <sup>2</sup> )

**Report Options**

- Print
- Save
- Copy
- Paste
- Refresh
- Help

**Annotations**

- Show Node/Element Number
- Show X,Y,Z Location
- Show Value

Annotations on the plot:

- Node: 6996, X, Y, Z Location: 19.3, 5.25, 7.5 mm, Value: 1.173423e+002 N/mm<sup>2</sup> (MPa)
- Node: 1581, X, Y, Z Location: 17.1, 10.45 mm, Value: 3.010330e+001 N/mm<sup>2</sup> (MPa)
- Node: 6997, X, Y, Z Location: 20, -0.364, 5 mm, Value: 1.614601e+002 N/mm<sup>2</sup> (MPa)
- Node: 1565, X, Y, Z Location: 18.4, -7.86, 5 mm, Value: 7.804337e+001 N/mm<sup>2</sup> (MPa)
- Node: 7033, X, Y, Z Location: 18.1, 8.55, 5 mm, Value: 7.025219e+001 N/mm<sup>2</sup> (MPa)
- Node: 7012, X, Y, Z Location: 17.3, -9.99, 5 mm, Value: 3.760085e+001 N/mm<sup>2</sup> (MPa)
- Min: 9.925206e+000
- Max: 4.083229e+002
- Node: 7007, X, Y, Z Location: 0.42, -20.5 mm, Value: 4.060943e+002 N/mm<sup>2</sup> (MPa)
- Node: 7011, X, Y, Z Location: 14.5, -13.8, 5 mm, Value: 8.839833e+001 N/mm<sup>2</sup> (MPa)
- Node: 1568, X, Y, Z Location: 12.7, -15.4, 5 mm, Value: 1.537381e+002 N/mm<sup>2</sup> (MPa)
- Node: 6981, X, Y, Z Location: 10.1, -17.3, 5 mm, Value: 2.469880e+002 N/mm<sup>2</sup> (MPa)
- Node: 1577, X, Y, Z Location: 3.83, -19.6, 5 mm, Value: 3.735007e+002 N/mm<sup>2</sup> (MPa)

Select points in this direction

Use the **Report Options** tools to save Probe Results.



#### 47 Plot Fatigue Check Plot.

Click **Define Fatigue Check Plot** .

Set the **Loading type** to **On/Off Loading** to indicate that the Tensile force may oscillate between 0 and 110,000 N.

Set the **Surface Finish Factor** to **Machined**. Keep the **Loading Factor** and **Size Factor** at their default values.

Under **Material** keep the **Scale this value** and **Minimum safety factor** fields at their default values of 1.

Click **OK** .

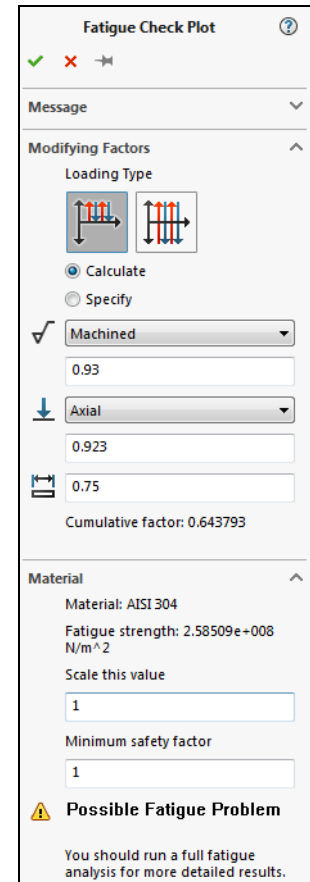
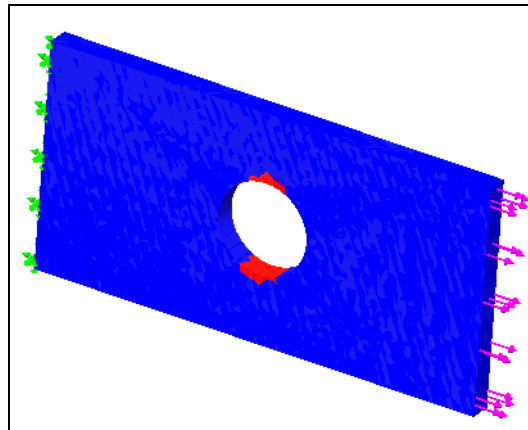

The areas in red indicate potential fatigue problems.

#### Note

If fatigue appears to be a concern, a more precise fatigue analysis should be considered. Analyses such as these are often performed using the SOLIDWORKS Simulation Professional fatigue module.

**48 Define P1: 1st Principal Stress plot.**

Click **Define Stress Plot** .

Select **P1: 1st Principal Stress** as the stress component, keep all other default options, and click **OK** .

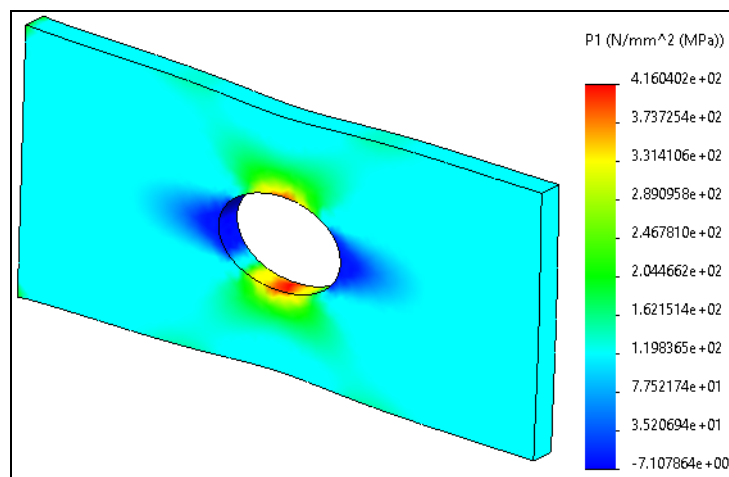
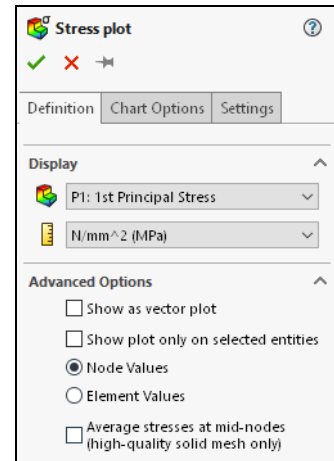

We observe that the maximum value of the 1st principal stress, 416 MPa, is very close to the maximum value of the Von Mises stress, 408 MPa. This is because the specified Tensile force is the only dominant load component resulting in predominantly tensile stress along the longitudinal direction of the plate.

## Multiple Studies

We have completed the analysis mainly using default mesh settings and now wish to see how changing the mesh density affects the results. For this reason, we will repeat the analysis two more times using both coarser and finer density meshes.

To repeat the analysis with coarsened mesh, we can create a new mesh while still in the default analysis study, but this action would overwrite the old results.

To preserve the results of the current study, we will create a new study, coarse analysis. Creating a new study can be done in several ways.

## Creating New Studies

New studies can be created in one of two ways:

- Create a new study from scratch.
- Copying an existing study: right-click the tab for the study you want to duplicate and click Copy Study.

When we copy a study, SOLIDWORKS Simulation displays the Copy Study window. This will allow us to name the duplicated study and choose the SOLIDWORKS configuration.

## Copy Parameters

When we create a new study, we can copy material, fixtures and external forces from existing studies rather than recreating them in the new study. To copy parameters, drag the parameter from the Simulation Study tree to the tab of the new study.

## Note

When a study is copied, the study settings, Fixtures, External Forces, Mesh, and the study results will be copied as well.

---

### 49 Copy the study.

Right-click the default analysis tab and click **Copy Study**.

Type coarse analysis for the study name. The model only has one configuration, so we cannot change it.

Click **OK** ✓.

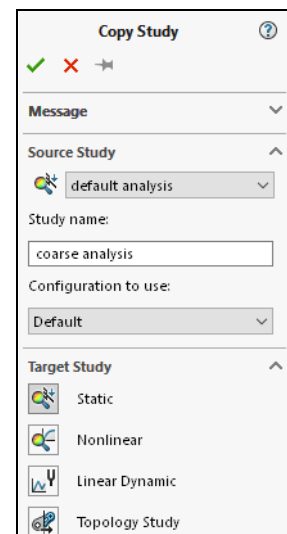

**50 Draft Quality Mesh.**

Right-click the rectangular hollow plate body from the Simulation tree and click **Apply Draft Quality Mesh** .

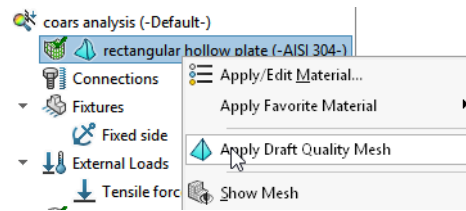
**Note**

Warnings appear in the Simulation tree once you specify draft quality elements, indicating that the study is now out of date.

**51 Create new mesh in coarse analysis study.**

In the coarse analysis study, click **Create Mesh** .

Move the **Mesh Density** slider all the way to the left. The **Maximum element size** should read **11.4491 mm** [0.4508 in].

Click **OK** .

The generated mesh is displayed below.

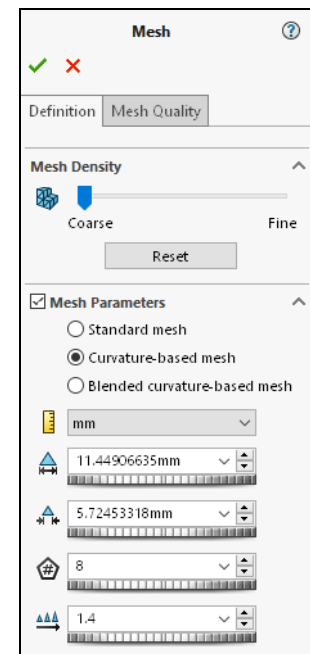
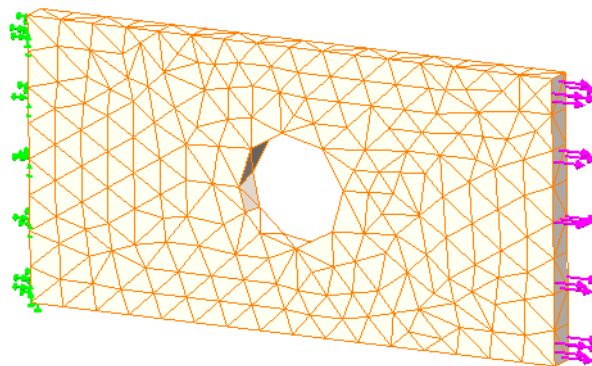
**Note**

The mesh is orange to indicate draft quality, and without the curvature created by mid-side nodes, the hole appears tessellated. Additionally, there is only one element across the thickness of the part; in the default analysis, there were two elements. Later, we will discuss why this sort of mesh is not acceptable for reliable analysis results.

### 52 Display mesh details.

Having created the mesh, we can access the detailed mesh information by right-clicking

**Mesh** and selecting **Details** .

The same detailed information can of course be displayed for the “old” mesh in the default analysis study.

Many of the items in this list will be discussed in later lessons.

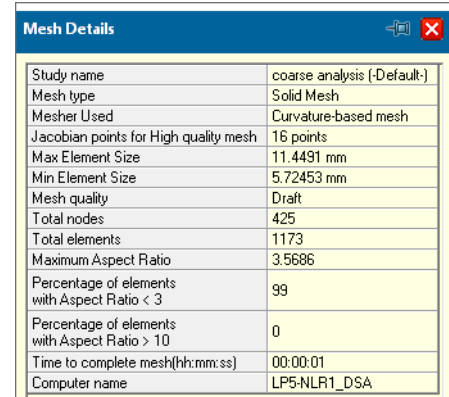

Mesh Details	
Study name	coarse analysis (-Default-)
Mesh type	Solid Mesh
Mesher Used	Curvature-based mesh
Jacobian points for High quality mesh	16 points
Max Element Size	11.4491 mm
Min Element Size	5.72453 mm
Mesh quality	Draft
Total nodes	425
Total elements	1173
Maximum Aspect Ratio	3.5686
Percentage of elements with Aspect Ratio < 3	99
Percentage of elements with Aspect Ratio > 10	0
Time to complete mesh(hh:mm:ss)	00:00:01
Computer name	LP5-NLR1_DSA

### 53 Run the analysis.

Click **Run** .

### 54 View displacement and stress results.

Record the maximum displacement from the Displacement1 plot (0.137 mm) and the maximum von Mises stress from the Stress2 plot (245 Mpa).

#### Note

All plot settings remain the same as the default analysis study because the plot definitions are copied from that study.

### 55 Re-run the analysis with fine mesh.

Repeat step 49 to copy the default analysis study. Name the new study, fine analysis.

Ensure the mesh uses **High Quality**  elements.

Click **Create Mesh** . When re-generating the mesh, move the slider all the way to the right. The **Maximum element size** should read **2.86227 mm** [0.1127 in].

Click **OK** .

The fine mesh generated using the above settings is shown to the right.

Notice that we now have several elements in the through-thickness direction. You will later learn that this mesh is acceptable for reliable analysis results.

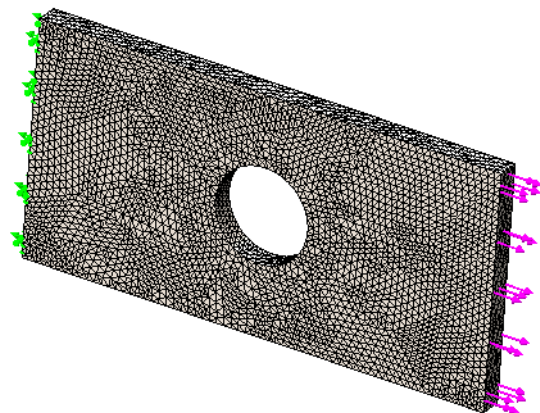

Click **Run** .

**56 View displacement and stress results.**

Record the maximum displacement from the Displacement1 plot (0.144 mm) and the maximum von Mises stress from the Stress2 plot (416 Mpa).

**Check Convergence and Accuracy**

Now we must collect information from all of the studies (default, coarse and fine analysis) to compare the displacement and maximum von Mises stress results for the various mesh refinements. We can determine the maximum displacement and the maximum von Mises stress results in plots.

We must also determine the number of elements and the number of nodes in each mesh. These can be found in the **Mesh Details** window of each respective mesh.

Finally, we must determine the number of degrees of freedom (DOF) in each model. To calculate this number, we could count the number of unconstrained nodes by subtracting the number of nodes on the constrained face from the number nodes reported in mesh details. Then we could multiply this number by three because each node in a solid element mesh has 3 DOF. An easier method, however, is to right-click the Results folder in each study and select **Solver Messages** (see below).

**57 View solver messages.**

Right-click **Results** folder and select **Solver Messages** . Note the number of elements, nodes, and degrees of freedom.

**Results Summary**

The summary of the results produced by the three studies is shown in the following table:

Mesh density	Max. displacement [mm]	Max. von Mises stress [MPa]	Number of DOF	Number of elements	Number of nodes
<b>coarse analysis</b>	.1374	245.5	1,221	1,173	425
<b>default analysis</b>	.1435	408.5	44,037	8,677	14,844
<b>fine analysis</b>	.1435	415.7	310,977	68,511	104,248

Note that all of the results of this table pertain to the same problem. The only difference is in the mesh density. You may find small differences between your own results and those presented in this table. This is due to service pack upgrades, etc. Having noted that the maximum displacement increases with mesh refinement, we can conclude that the model becomes less stiff (or softer) when the number of degrees of freedom increases. In our case, by selecting second order elements, we impose the assumption that the displacement field in each element is described by second order polynomial functions.

With mesh refinement, the displacement field in each element is still described by second order polynomial functions; however, the larger number of elements makes it possible to approximate the real displacement and stress fields more accurately.

We can say that the artificial constraints resulting from element definition become less imposing with mesh refinement. Displacements are always the primary unknowns in FEA, and stresses are calculated based on displacement results. Therefore, stresses also increase with mesh refinement. If we continued with mesh refinement, we would see both displacement and stress results converge to a finite value. This limit is the solution of the mathematical model. Differences between the solution of the FEA model and the solution of the mathematical model are due to discretization error. Discretization error diminishes with mesh refinement.

The process of consecutive mesh refinements that we have completed is called the convergence process. Its objective is to determine the impact of our discretization choices (element size) on the data of interest, which, in this lesson, are the maximum resultant displacements and the maximum von Mises stress.

**Comparison with Analytical Results**

An infinitely long rectangular hollow plate under a tensile load possesses an analytical solution [1]. We compare FEA results with analytical results.

W, D and T denote plate width (100 mm), hole diameter (40 mm) and plate thickness (10 mm). P is the tensile load 110,000 N or 24,729 lb. For comparison with analytical results, it is more convenient to use the SI system because the SOLIDWORKS model have been defined in mm.

$\sigma_n$  is the normal stress in the cross section where the hole is located,  $K_n$  is the stress concentration factor, and  $\sigma_{max}$  is the maximum principal stress.

$$\sigma_n = \frac{P}{(W - D) \times T} = \frac{110000}{(100 - 40) \times 10} = 183.33 \text{ MPa}$$

$$K_n = 3 - 3.13 \left( \frac{D}{W} \right) + 3.66 \left( \frac{D}{W} \right)^2 - 1.53 \left( \frac{D}{W} \right)^3 = 2.23568$$

$$\sigma_{max} = K_n \times \sigma_n = 183.33 \times (2.23568) = 409.87 \text{ MPa}$$

Review the **P1: 1st principal stress** plot for study default analysis. The maximum value reached 415.59 MPa, which corresponds to approximately 60.3 ksi.

Therefore, the difference is:

$$\text{difference} = \left[ \frac{\text{NumericalSolutions} - \text{THEORY}}{\text{NumericalSolutions}} \right] = \left[ \frac{415.7 - 409.9}{415.7} \right] = 1.4$$

The difference of 1.40% between the SOLIDWORKS Simulation result and the analytical solution does not necessarily mean that the SOLIDWORKS Simulation result is worse and has a 1.40% error.

We must be very careful in how we compare these results. Note that the analytical solution is valid only for a very thin plate where a plane stress condition is assumed. SOLIDWORKS Simulation calculates a solution for a 3D model with substantial thickness (10 mm) and accounts for realistic stress distribution across the plate thickness. SOLIDWORKS Simulation also takes into consideration the fact that the plate has a finite length (200 mm) rather than an infinite one, as the analytical solution does.

Furthermore, detailed inspection of the stress results show the stress gradient across the plate thickness, which is not accounted for in the analytical model. Thus, we can conclude that SOLIDWORKS Simulation provides more detailed stress information than the analytical solution.

## Reports

Results may need to be recorded in report form for review, presentation or archive purposes.

Reports can be published in Microsoft Word format. Different sections can be added to the report from a list of predefined commonly used topics. The default settings for the **Reports** can be found in the **Simulation, Options** menu.

Predefined sections include:

- Description
- Model Information
- Units
- Loads and Fixtures
- Contact Information
- Sensor Details
- Beams
- Conclusion
- Assumptions
- Study Properties
- Material Properties
- Connector Definitions
- Mesh Information
- Resultant Forces
- Study Results
- Appendix

To edit the content of a section, select the section in the Included sections and fill in the appropriate section properties.

### Where to Find It

- Menu: **Simulation, Report** 
- CommandManager: **Simulation > Report**

---

### 58 Generate report in Microsoft Word format.

Ensure fine analysis is active and click **Report** .

The **Report Options** window opens.

**59 Add sections.**

Under **Report sections**, ensure each selection is relevant to this analysis. (For example, you could deselect the option **Contact Information**, as we do not have any in this analysis.)

Enter your **Header information** and click **Publish**.

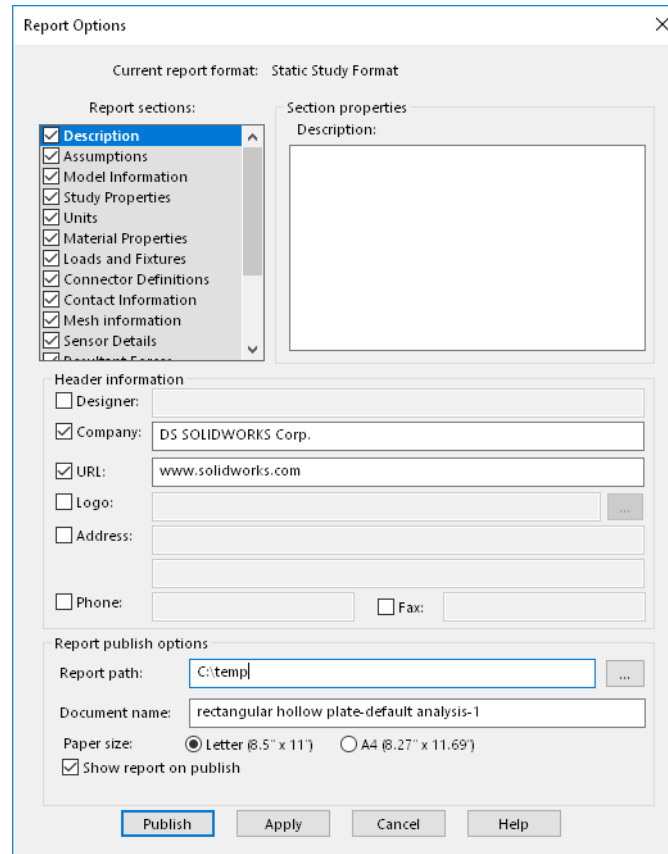
**60 Examine the report.**

Open the report in Microsoft Word and examine the results.

**61 Save and Close the file.**

## Summary

We used a model of a hollow rectangular plate to introduce the SOLIDWORKS Simulation interface and set up a simulation from start to finish.

We created multiple studies to execute a linear static analysis with three different meshes.

While preparing models for analysis and examining results obtained with different meshes, we introduced the concept of modeling error and discretization error.

This first lesson was intended to provide an understanding of FEA methodology and the software skills necessary to complete the lessons that follow.

## References

1. Young and Budynas, Roark's Formulas for Stress and Strain, 7th Edition.

## Questions

- The preprocessing stage of the FEA includes the following steps:
  1. \_\_\_\_\_
  2. \_\_\_\_\_
  3. \_\_\_\_\_
  4. \_\_\_\_\_
  5. \_\_\_\_\_

- The density of finite element mesh (does / does not) have considerable impact on the analysis results.

- In general, we would favor (finer / coarser) meshes to obtain reliable analysis results. Therefore, the time required to solve the analysis will (increase / decrease), but this is an unavoidable consequence.

Ultimately, we will try to design optimum meshes providing reasonable accuracy levels and resulting in acceptable run times.

- The primary unknown in finite element analysis is (displacements / strains / stresses). This quantity is therefore the most accurate.
- The accuracy levels of (displacements / strains / stresses) and (displacements / strains / stresses) are approximately the same, but significantly worse than that of (displacements / strains / stresses). Therefore, to obtain good (displacement / strain / stress) results, the mesh must be reasonably fine.
- (Refining / Coarsening) the mesh results in solutions approaching the analytical solution of a mathematical model.

**Exercise 30:  
Bracket**

In this first exercise, you will analyze a simple part with an External Load and a single Fixture applied to two faces.

This exercise reinforces the following skills:

- *SOLIDWORKS Simulation Options* on page 266
- *Fixtures* on page 272
- *External Loads* on page 275
- *Meshing* on page 280
- *Multiple Studies* on page 300

**Problem  
Statement**

The aluminum part of an assembly will be analyzed for its maximum stresses and displacements. The part is bolted to the rest of the assembly through the two bolt holes, as indicated in the figure. The part is then subjected to a normal force of 500 N, applied to the counter bored face.

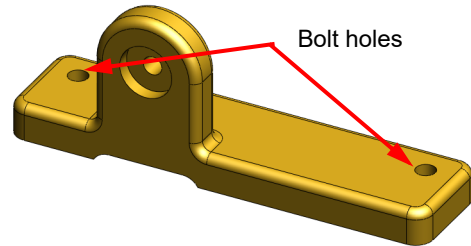
**1 Open a part file.**

Open Bracket.SLDPRT from the Lesson01\Exercises\Bracket folder.

**2 New Default Plot.**

Browse to the **Default Options** tab.

Right-click the **Static Study Results** folder and click **Add New Plot**.

Under **Results type**, specify **Nodal Stress**, and under **Results component**, specify **P1: 1st Principal Stress**.

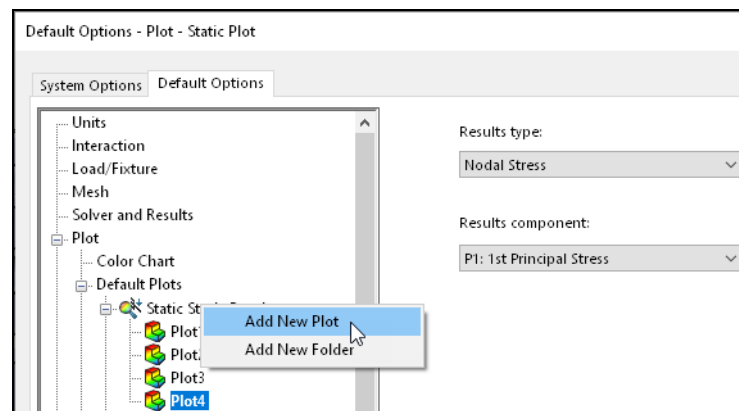

- 3 Number format.**  
Click **Color chart**.

Under **Number format**, specify **Scientific** and 2 decimal places.

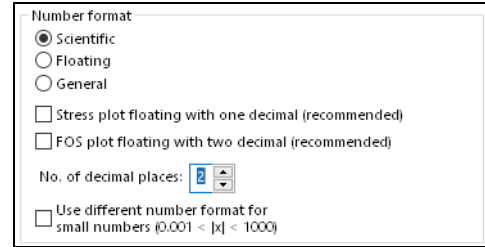

- 4 Define a static study.**  
Create a new static study named **stress analysis**.

- 5 Apply material properties.**  
Click **Apply/Edit Material** .

Specify **Aluminum 1060 Alloy** from the SOLIDWORKS materials library.

Click **Apply** and **Close**.

- 6 Apply Fixtures.**  
Click **Fixed Geometry** .

Apply the fixture to the faces as shown in the figure below.

Click **OK** .

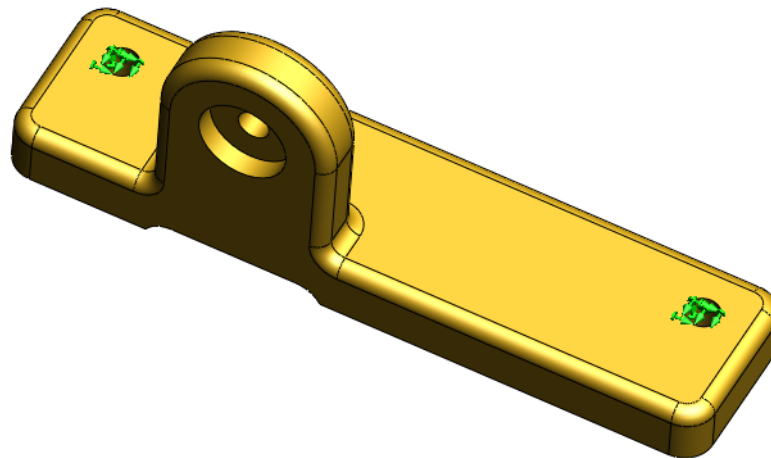

This Fixed Geometry fixture represents two bolts that mount the bracket to a larger assembly. In SOLIDWORKS Simulation, Fixtures, External Loads, and Connections represent geometry not explicitly modeled.

In later lessons, you will learn more accurate and elegant methods to simulate these conditions.

**7 Apply external load.**

Click **Force** .

Select the inner face as indicated in the diagram and specify the direction of the load as **Normal** to the selected face with a **Force Value** of 500 N.

Click **OK** .

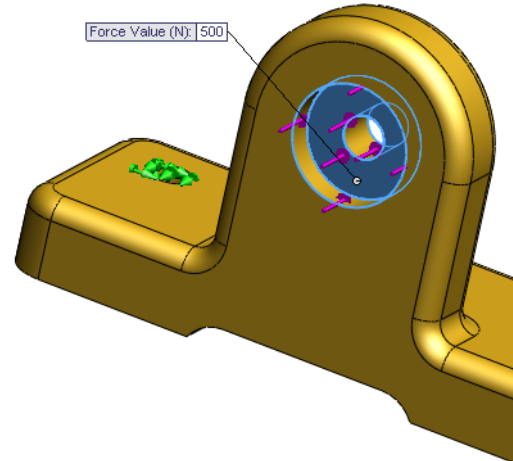
**8 Mesh.**

Click **Create Mesh** .

Specify a **Blended curvature-based mesh** with default element sizes.

Click **OK** .

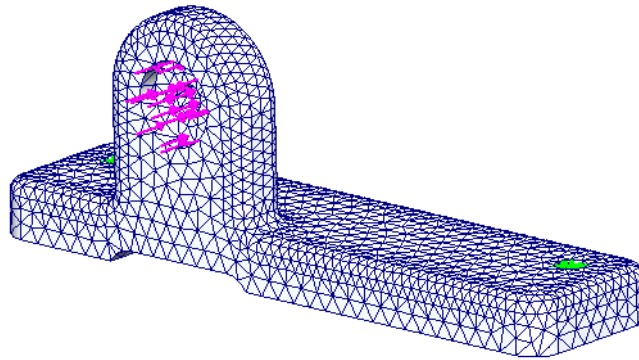
**9 Run the study.**

### 10 Plot stress results.

We observe that the maximum von Mises stress in the model is approximately 37.7 MPa, which is above the yield strength of the 1060 Aluminum Alloy (27.6 MPa).

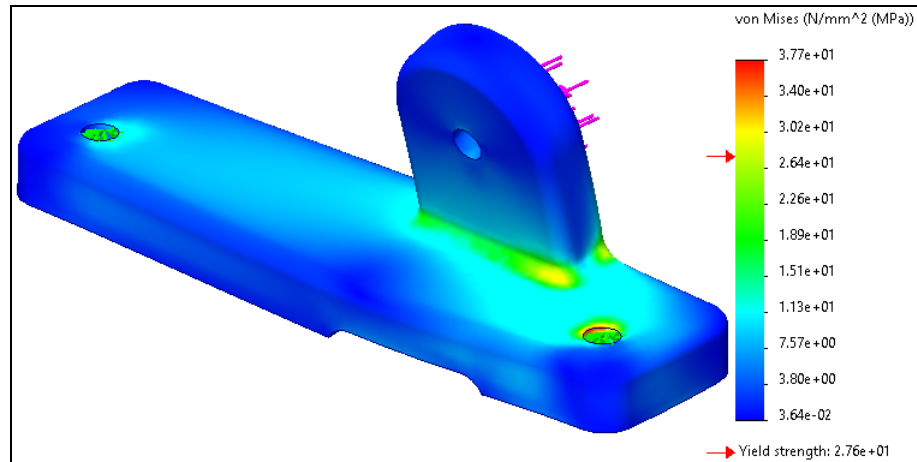

### 11 Principal stress.

The distribution of the **P1: 1st principal stress** indicates a maximum value of approximately 45 MPa. This value corresponds to the maximum tensile stress in the part (maximum compressive stress where the value is negative).

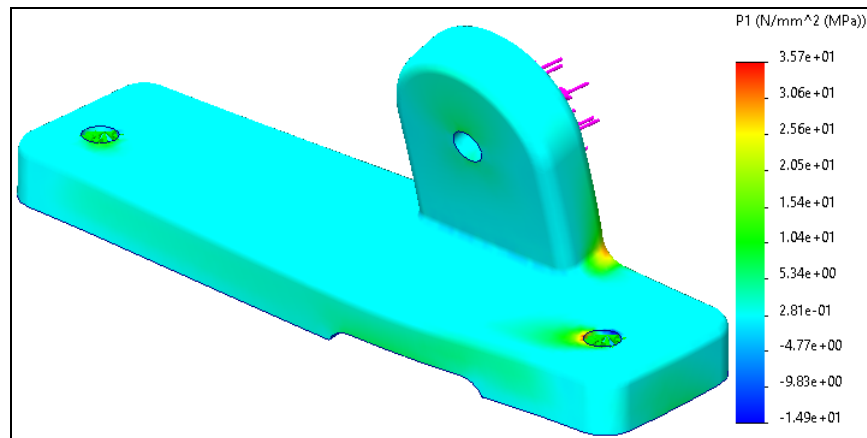

### 12 Probe von Mises stress on the fillet.

Later in the course you will learn that the fixtures may result in stress intensifications which are not real. For this reason, we will focus our attention to the filleted region between the horizontal and vertical bosses on the part.

Click Stress1.

Click **Probe** .

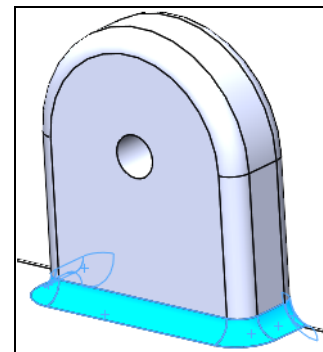

Select **On selected entities**, then pick the seven faces of the fillet between the two bosses.

Click **Update**.

**Probe Result**

Options

- At location
- From sensors
- On selected entities
- At Node number

Results

- Face<3>
- Face<4>
- Face<5>
- Face<6>
- Face<7>

Flip edge plot

Update

Node	Value (N/mm <sup>2</sup> (MPa))	
13	1.56e+01	1
14	1.38e+01	1
21	9.54e+00	2
22	1.20e+01	2
40	1.35e+01	1
41	1.30e+01	1
42	1.90e+01	1
43	1.09e+01	2

Summary

	Value	Unit
Sum	4.73e+03	N/mm <sup>2</sup> (MPa)
Avg	1.56e+01	N/mm <sup>2</sup> (MPa)
Max	2.88e+01	N/mm <sup>2</sup> (MPa)
Min	5.13e+00	N/mm <sup>2</sup> (MPa)
RMS	1.63e+01	N/mm <sup>2</sup> (MPa)

Note the values in the **Summary** section.

### 13 Plot displacement results.

We observe the maximum resultant displacement of approximately 0.068 mm.

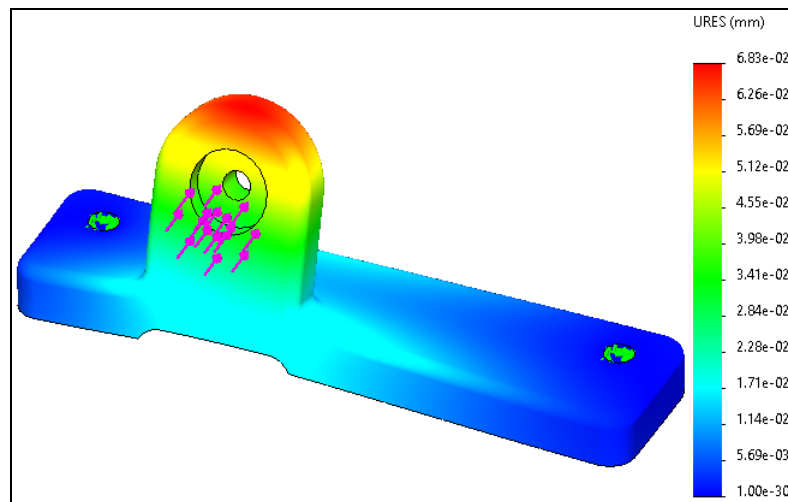

### Coarse Mesh and Element Stress

Are the current results accurate enough? Visual inspection of our finite element mesh suggests that it may be rather coarse, especially in the regions where the fillets are present. Furthermore, inspection of the distribution of the elemental values of the von Mises stress indicates considerable stress jumps from element-to-element in the higher stress concentration areas.

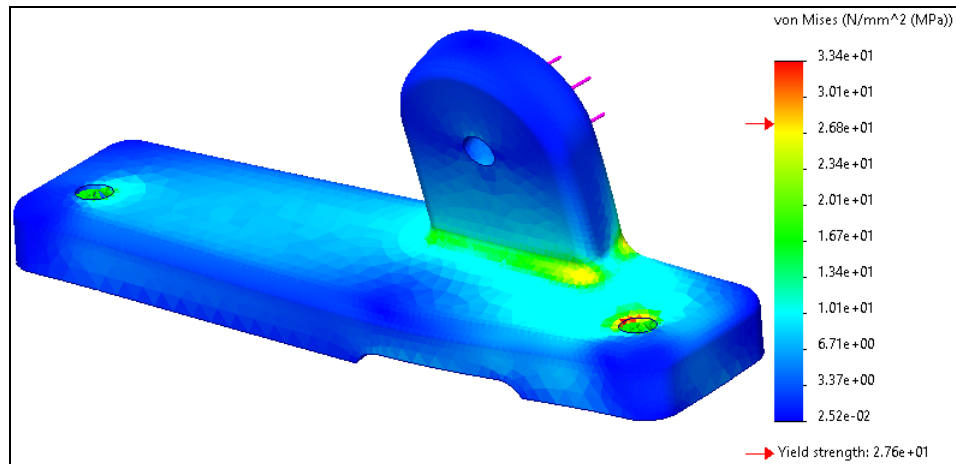

We will repeat the analysis with a finer mesh.

### 14 Create new static study.

Copy the study stress analysis as a new study named stress analysis - refined.

The folders **Fixtures**, **External Loads**, **Parts**, **Mesh**, and **Results** are copied into the new study as well.

**15 Create fine mesh.**

Slide the Mesh Density slider all the way to the right which will result in an **Maximum element size** of 2.198 mm and a **Minimum element size** of 0.733 mm.

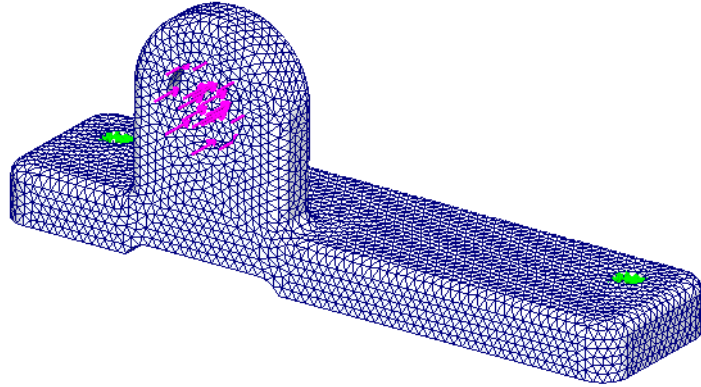

The resulting mesh shows significantly improved mapping of the model geometry.

**16 Run the study.****17 Plot stress results.**

We now observe that the maximum von Mises stress increased to 39.8 MPa, which is still above the material yield strength of the 27.6 MPa. However, if we examine the plot, we will see that the maximum stress is at the sharp corner of the bolt holes. We will discuss this further in the next lesson.

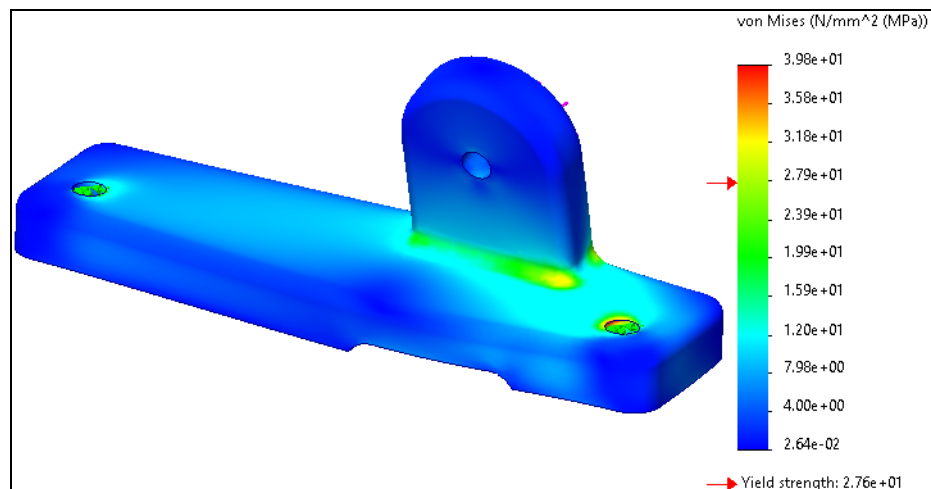

**18 Probe stress on the fillet.**

Using the identical procedure described in step 12, probe the stress results on the filleted geometries.

The maximum von Mises stress on the fillet increased from 28.8 MPa to 30.5 MPa.

**19 Plot displacement results.**

The maximum resultant displacement increased, but only slightly.

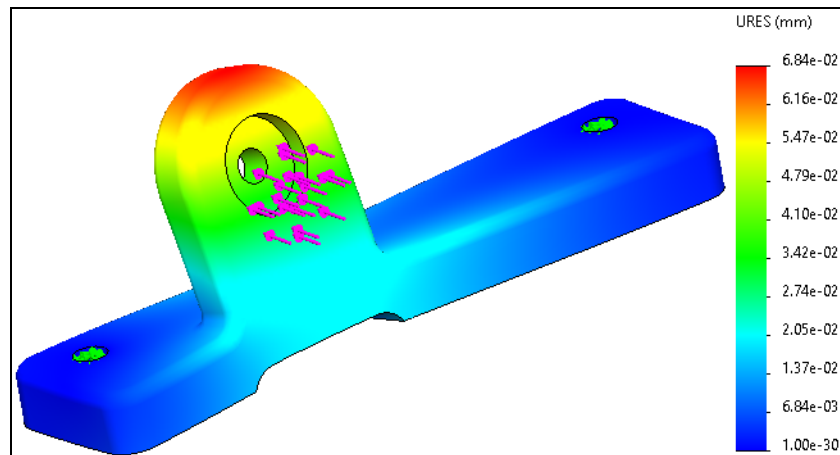

**20 Delete plot.**

The plot created in step 2 on page 309 will be propagated to all future simulations unless it is deleted.

Click **Options** from the **Simulation** menu.

Right-click Plot4 and click **Delete**.

Click **OK**.

**21 Save and Close the file.**

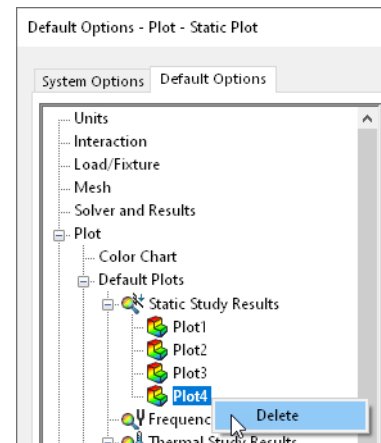

## Summary

This exercise reinforced the processes required to set up a linear static study and post-process the results. Demonstrations showed how the size and the quality of the mesh affects result outputs, particularly stress results. While the deviation in the resultant displacements between the two studies was less than 1%, the deviation for maximum von Mises stresses was more significant, which is often the case. We attribute the high difference in maximum stress results to the following two phenomena:

- Displacements are the primary unknown in the finite element analysis and, as such, will always be significantly more accurate than strains and stresses. A relatively coarse mesh is sufficient for satisfactory displacement results, while significantly finer mesh is generally required for satisfactory stress results.
  - The extreme values of the stresses occur in the vicinity of the fixture where the stresses often assume unrealistically high values. This is a subject studied in the next lesson. The stresses at the filleted regions reported in both studies were closer in their magnitudes with a negligible difference. Finer meshes are required in filleted regions as stress results are of importance to us.
- 
-

## Exercise 31: Compressive Spring Stiffness

In this exercise, you will determine the compressive stiffness of a coil spring.

This exercise reinforces the following skills:

- *New Study* on page 269
- *Fixtures* on page 272
- *External Loads* on page 275
- *Meshing* on page 280
- *Result Plots* on page 285

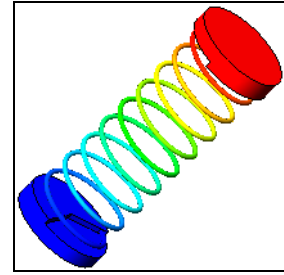

### Problem Statement

Following Hooke's law, a "spring constant" defines a spring's stiffness by relating displacement to an applied load through the equation  $f = kx$ , where "f" is force, "x" is displacement, and "k" is the spring constant. Create a simulation to determine the spring constant for a model of a spring made from Alloy Steel.

#### 1 Open a part file.

Open spring from the Lesson01\Exercises\Spring - Compressive Spring Stiffness folder.

### Note

For convenient application of fixtures and external loads, disks have been added to both ends of the spring. The distance between the disks corresponds to the active length of the uncompressed spring.

#### 2 Set SOLIDWORKS Simulation options.

Set the system of **Units** to **SI (MKS)** and the units of **Length** and **Stress** to **mm** and **N/m<sup>2</sup> (Pa)**.

#### 3 Static Study Results.

Ensure the **Default Plots** are set to create plots for **Nodal von Mises Stress**, **Resultant Displacement**, and **Elemental Equivalent Strain**.

#### 4 Create study.

Create a **Static** study named spring stiffness.

#### 5 Review material properties.

The material properties (**Alloy Steel**) are transferred from SOLIDWORKS.

**6 Apply Fixed restraint.**

Apply a **Fixed Geometry** fixture to the end face of one disk (item 1 from the image below).

**7 Apply radial restraint.**

Use an advanced fixture to apply a restraint in the radial direction to the cylindrical face of the other disk (item 2).

This restraint only allows the spring to be compressed (or expanded) in its axial direction and to rotate about the longitudinal axis.

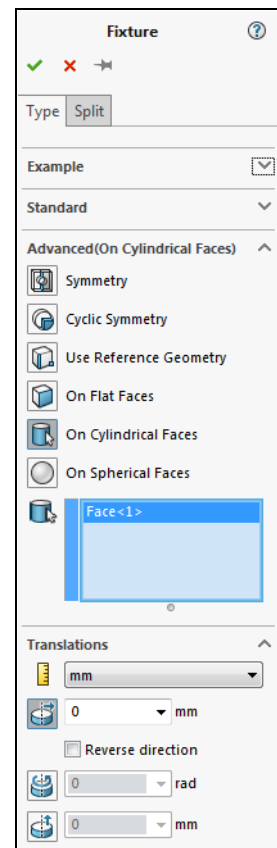
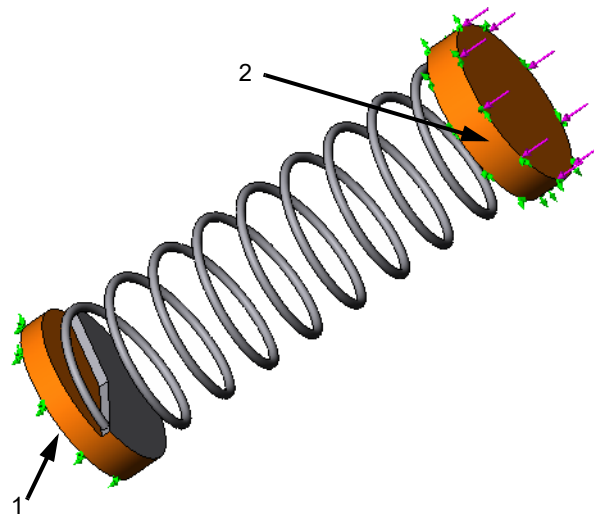
**8 Apply compressive force.**

Apply a 0.1 N compressive force to the end face of the disk with the cylindrical face constrained in the radial direction.

**9 Mesh the model and run the analysis.**

Select **Curvature based mesh** under **Mesh Parameters**.

Specify a **Maximum element size** and **Minimum element size** of 2.787 mm and 0.557 mm, respectively.

**10 Run the study.**

### 11 Plot z displacements.

Displacement results indicate an axial displacement of 0.426 mm. The axial displacement is in the z direction.

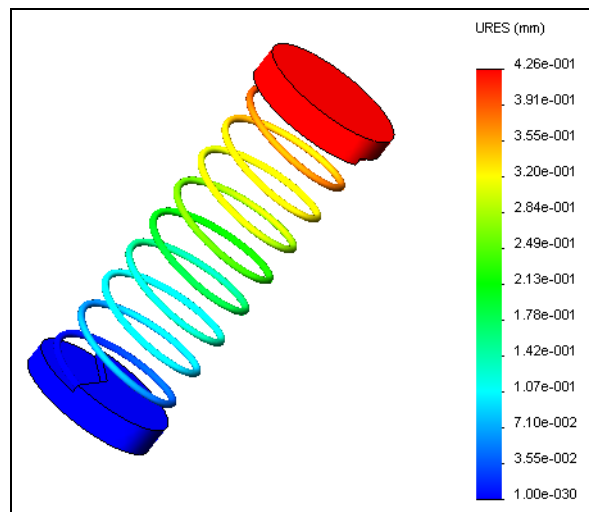

---

---

### Coil Spring Axial Stiffness

The axial stiffness of the spring can be calculated from the equation  $k = f/x$ . Using this equation, we determine that the spring stiffness ( $k$ ) for this example is .235 N/m (or 234.7 N/mm).

Alternately, we could use an approximate formula for the stiffness of a helical spring (Mechanical Vibrations by S. S. Rao, 1995).

$$K_{\text{Axial}} = \frac{Gd^4}{8nD^3}$$

where:

- **G** is the material shear modulus
- **d** is the diameter of the wire
- **D** is the mean coil diameter
- **n** is the number of active turns

Substituting our values ( $n = 8.75$ ,  $d = 1$  mm,  $D = 17$  mm, and  $G = 7.9e10$  Pa) into the above formula gives an axial stiffness of approximately 230 N/mm. This result is very close to our actual result of 234.7 N/mm.

---

---

### 12 Save and Close the file.

---

---

## Exercise 32: Container Handle

In this exercise, you will assess the safety of the waste container handle.

This exercise reinforces the following skills:

- *New Study* on page 269
- *Fixtures* on page 272
- *External Loads* on page 275
- *Meshing* on page 280
- *Result Plots* on page 285

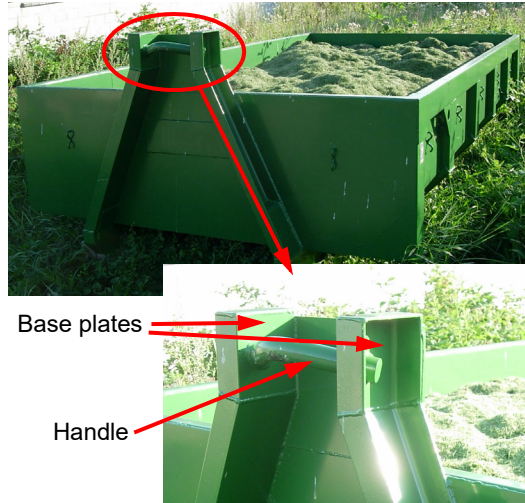

### Problem Description

The handle attaches to a wench hook to lift the container. The entire container is manufactured from AISI 304 steel. The handle is welded (double-sided fillet weld) to the two square base plates located symmetrically on both sides. The diameter of the handle is 30mm; the thickness of the steel plates is 5mm. Apply the most suitable fixtures to simulate the connection between the handle and the steel plates.

### Loading Conditions

In the most extreme loading situation, when the container is pulled onto the truck rails, the handle is loaded by a 3000 N force inclined at 15 degrees. The force should be applied on the circular split face indicated in the figure above.

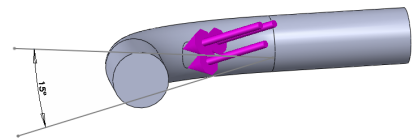

The geometry of the handle structure with the base plates is shown in the figure to the right.

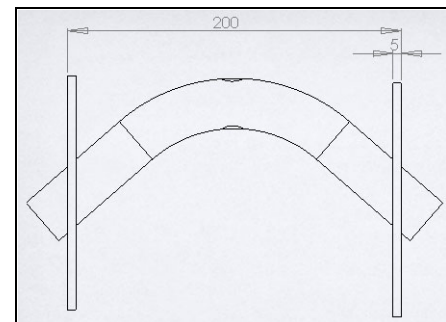

### Goal

Decide whether the design of this handle is safe. Pay attention to the most appropriate representation of the fixture.

The part for this exercise is located in the Lesson01 \Exercises \Container Handle folder.



# Lesson 8

## Introduction to Motion Simulation and Forces

### Objectives

Upon successful completion of this lesson, you will be able to:

- Use Assembly Motion to animate the motion of a car jack assembly.
- Use SOLIDWORKS Motion to simulate physical behavior of the car jack and determine the torque required to lift a vehicle.

## Basic Motion Analysis

In this lesson, we will perform a basic motion analysis using SOLIDWORKS Motion to simulate the weight of a vehicle on the jack and determine the torque required to lift it. Engineers can then use this information to choose the required electric motor to drive the car jack.

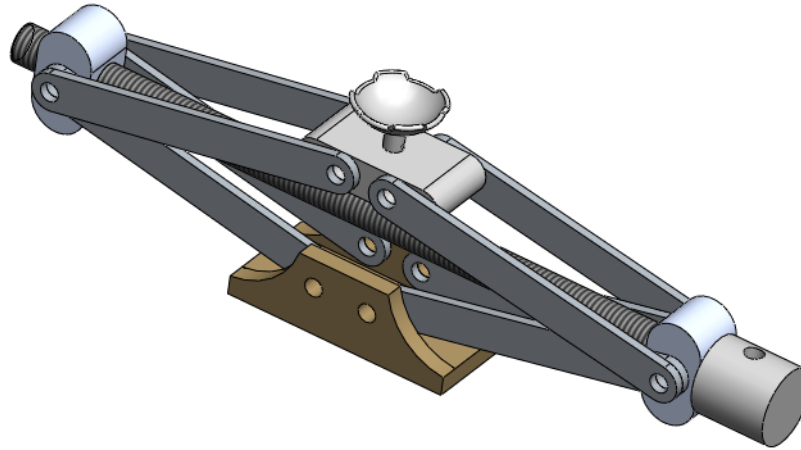

## Case Study: Car Jack Analysis

A mechanical jack is a device that lifts heavy equipment. The most common form is a car jack, floor jack, or garage jack which lifts vehicles so that maintenance can be performed. Car jacks usually use mechanical advantage to allow a human to lift a vehicle. More powerful jacks use hydraulic power to provide more lift over greater distances. Mechanical jacks are usually rated for a maximum lifting capacity (e.g., 1.5 tons or 3 tons).

Because this is our first motion analysis, no contact is used and the tilting motion of the jack is prevented with the help of the mates.

## Problem Description

The car jack will be driven at a rate of 100 RPM and will be loaded with a force of 8,900 N, representing the weight of a vehicle. Determine the torque and power required to lift the load through the range of motion of the jack.

**Stages in the Process**

- **Create a Motion Study.**  
This will be a new motion study.
- **Add a rotary motor.**  
The rotary motor will drive the jack.
- **Add gravity.**  
Normal gravity will be added so that the weight of the car jack components are considered in the calculations.
- **Add the weight of the car.**  
The weight of the car will be added as a downward force on the Support.
- **Calculate the motion.**  
The default analysis will run for five seconds but we will increase it to allow the jack to extend fully.
- **Plot the results.**  
We will create various plots to show the torque and power required.

- 1 **Ensure that SOLIDWORKS Motion is added in.**  
Under **Tools, Add-ins**, make sure **SOLIDWORKS Motion** is checked.  
Click **OK**.
- 2 **Open an assembly file.**  
Open Car\_Jack from the Lesson01\Case Studies folder.

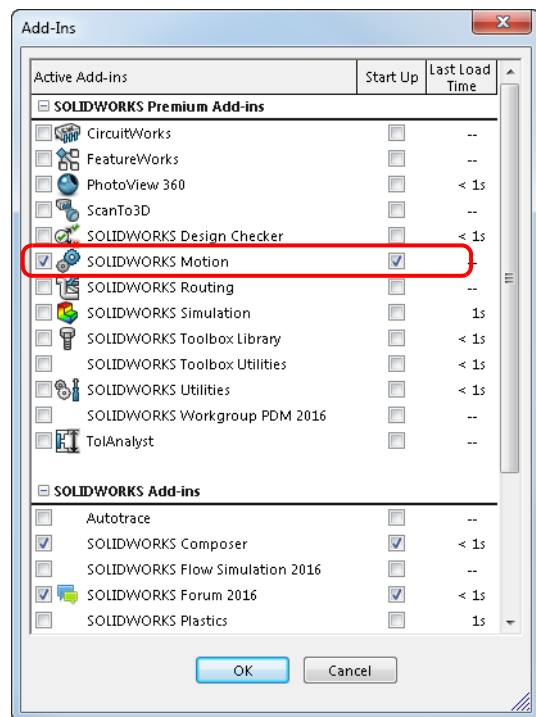

**3 Set the document units.**

SOLIDWORKS Motion uses the document units set in the SOLIDWORKS document.

Click **Tools, Options, Document Properties, Units**.

Select **MMGS (millimeter, gram, second)** for the **Unit system**. This will set our length units to millimeters and force to Newtons.

Click **OK**.

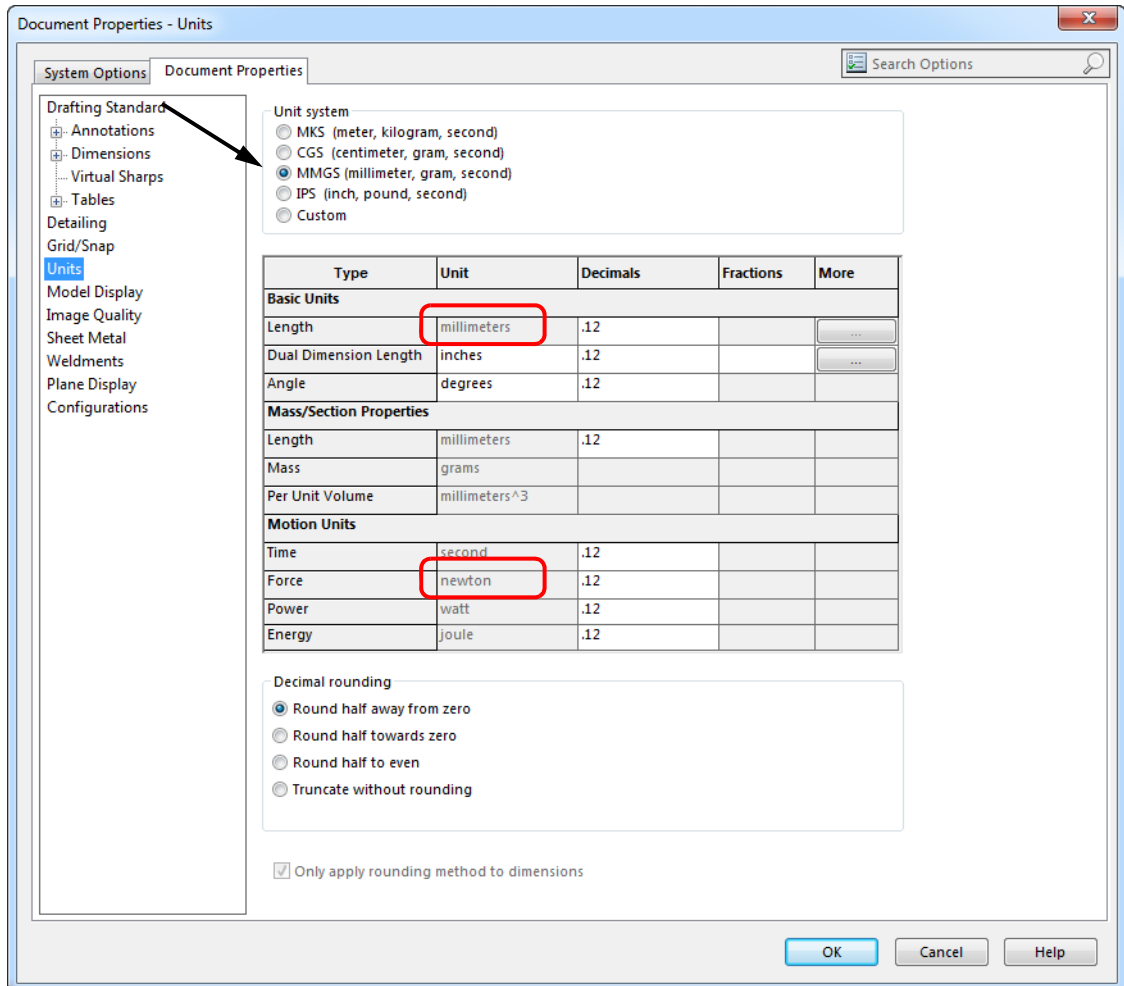

#### 4 Change to the Motion Study.

Click on the Motion Study 1 tab that appears at the bottom left-hand corner of the window. If this tab is not visible, click **View, User Interface, MotionManager**.

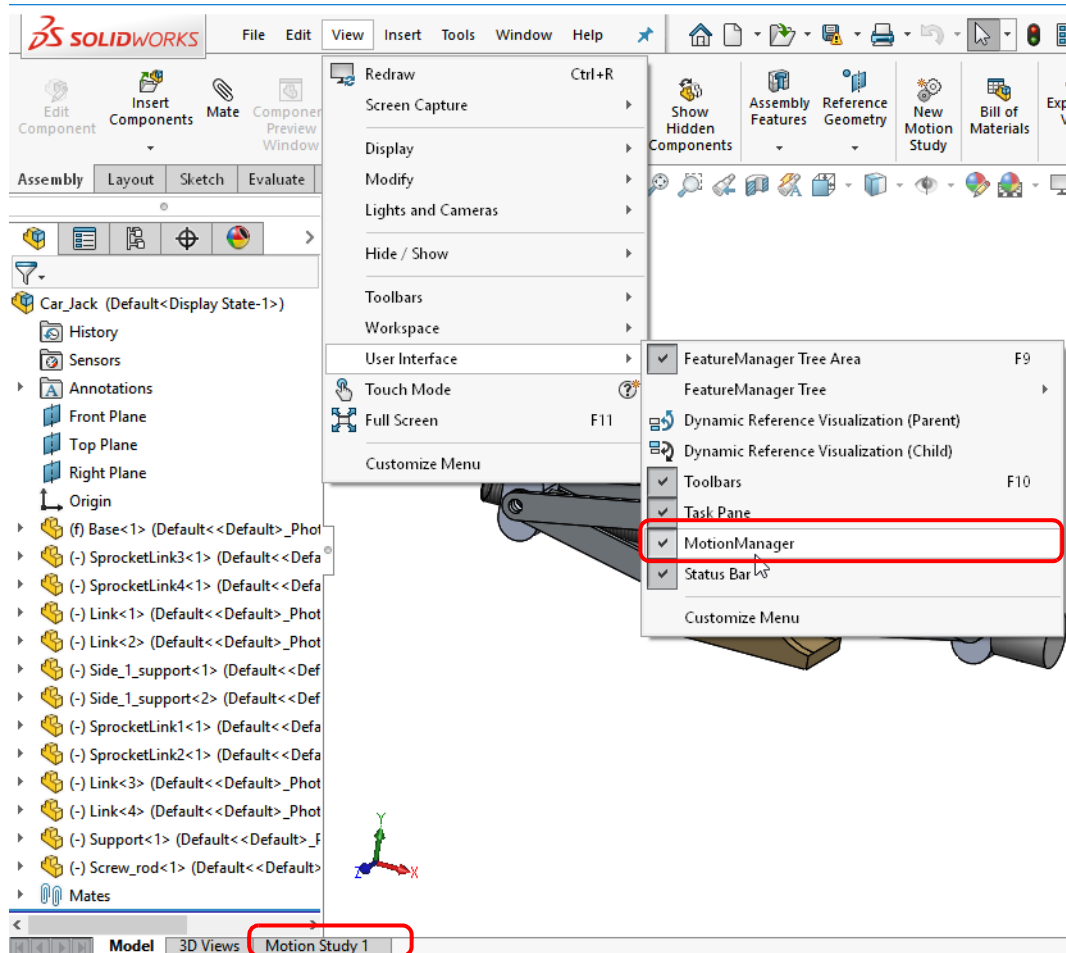

## 5 Activate the Motion Type of Study.

Select **Motion Analysis** from the list of available study types.

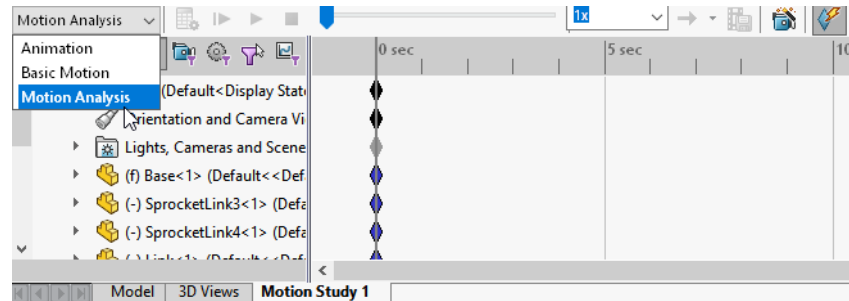

### Note

An **Animation** is used to create animations for illustration purposes. A **Basic Motion** analysis can be used to create animations where gravity, mass and collisions are applied to the parts in the model. **Motion Analysis** is a complete rigid body simulation environment used to obtain numerically accurate, physics based data and animations.

### Driving Motion

Motion can be driven by gravity, springs, forces or motors. Each has different characteristics that can be controlled.

### Introducing: Motors

Motors can create either linear, rotary or path dependent motion or prevent motion. This motion can be defined in a number of different ways.

- **Constant Speed**  
The motor will drive at a constant velocity.
- **Distance**  
The motor will move for a fixed distance or degrees.
- **Oscillating**  
Oscillating motion is a back and forth motion at a specific distance at a specified frequency.
- **Segments**  
Motion profile is constructed from segments of the most commonly used functions such as linear, polynomial, half-sine and others.
- **Data Points**  
Interpolated motion is driven by a tabular set of values.
- **Expression**  
The motor can be driven by a function created from existing variables and constants.
- **Servo Motor**  
The motor used to implement control actions for the event-based triggered motion.

### Where to Find It

- MotionManager toolbar: Click **Motor** 

**6 Create a Motor that drives the Screw\_rod at 100 RPM.**

Click **Motor** .

Under **Motor Type**, select **Rotary Motor**.

Under **Component Direction**, select the cylindrical face of the Screw\_rod part as shown in the figure. The **Motion Direction** field will automatically populate the same face to specify the direction.

Use the **Reverse Direction** button to orient the motor (see the figure).

Leave the **Component to Move Relative to** field empty. This ensures that the motor direction is specified with respect to the global coordinate system.

Under **Motion**, select the **Constant speed** and enter a value of 100 RPM.

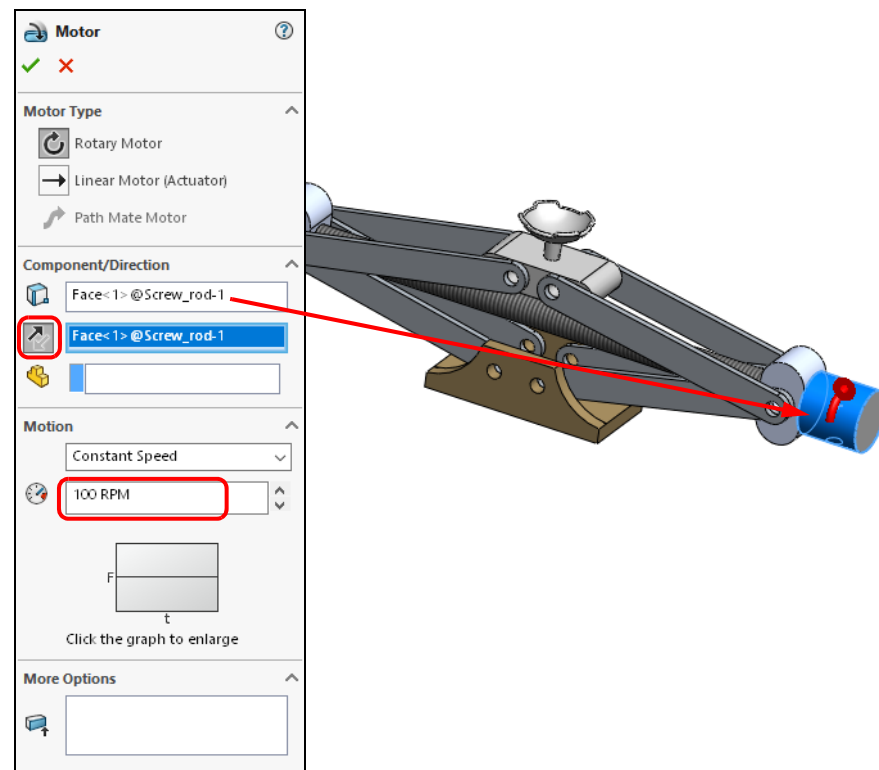

**Important!**

Make sure that the motor is oriented as shown in the figure.

Click the graph to enlarge in the PropertyManager to view the enlarged plot.

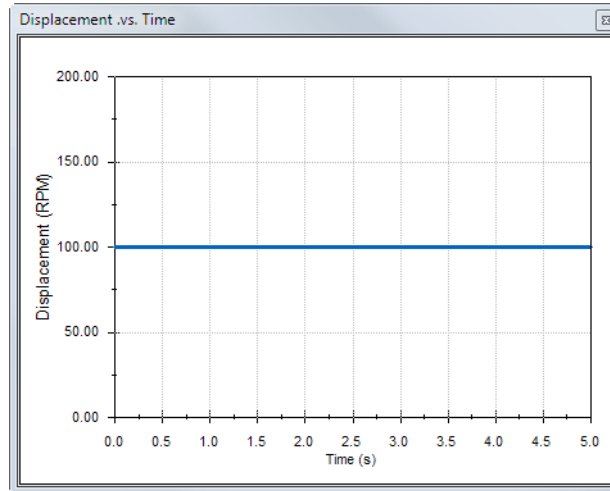

Close the graph plot.

Click **OK** ✓ .

---

## Gravity

Gravity is an important quantity when the weight of a part has an influence on its simulated motion, such as a body in free fall. In SOLIDWORKS Motion, gravity consists of two components:

- Direction of the gravitational vector
- Magnitude of the gravitational acceleration

The Gravity Properties allows you to specify the direction and magnitude of the gravitational vector. You can specify the gravitational vector by selecting the X, Y and Z direction or by specifying a reference plane. The magnitude must be entered separately. The default value for the gravitational vector is Y and the magnitude is  $9806.55 \text{ mm/sec}^2$  or the equivalent in the currently active units.

### Where to Find It

- MotionManager toolbar: Click **Gravity** 

---

#### 7 Apply Gravity to the assembly.

Click **Gravity**  .

For **Gravity Parameters**, **Direction Reference**, select the **Y** direction.

Under **Numeric gravity value**, type in a value of  $9806.65 \text{ mm/sec}^2$ .

Click **OK** ✓ .

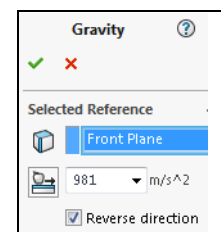

## Forces

Force entities (including both forces and moments) are used to effect the dynamic behavior of parts and sub-assemblies of a motion model and are usually a representation of some external effect acting on the analyzed assembly.

Forces may resist or induce motion, and are defined using similar functions that are used to define motors (constant, step, function, expression or interpolated).

Forces in SOLIDWORKS Motion can be divided into two basic groups:

### ■ Action Forces

A single applied force or moment representing the effect of the external objects and loadings on the part or sub-assembly. The weight of the vehicle applied on the car jack or an aerodynamic force on the car body are examples of action forces.

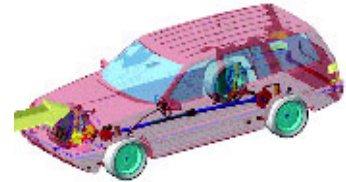

### ■ Action and Reaction Forces

A pair of forces or moments, both action and corresponding reaction, are applied on the parts or sub-assemblies.

A spring force could be understood as action and reaction force because both the forces on both end of the spring are on the same line of action. Another example would be a person pushing with his/her arms on the two opposing parts of an assembly. Such a person can then be represented in the motion analysis by a pair of two opposing forces of equal magnitude on the same line of action, i.e. action and reaction forces.

## Understanding Forces

### Applied Forces

A force can define load or compliance on a part. SOLIDWORKS Motion provides the following type of forces:

Applied forces are forces that define loads at specific locations on a part. You must provide your own description of the force behavior by specifying a constant force value or a function expression. The applied forces available in SOLIDWORKS Motion are the applied force, applied torque, action/reaction force and action/reaction torque.

The orientation of action-only forces can be fixed or relative to the orientation of any part in the mechanism.

Applied forces are used to model inputs such as actuators, rockets, aerodynamic loads and many more.

### Force Definition

To define a force the following information must be specified:

- Part or parts on which the force acts
- Point of the force application
- Magnitude and direction of the force

### Where to Find It

- MotionManager toolbar: Click **Force** 

## Force Direction

The force direction is based on the reference part you select in the **Force Direction** box. An illustration below gives you the three cases on how the force direction changes based on the selected reference parts.

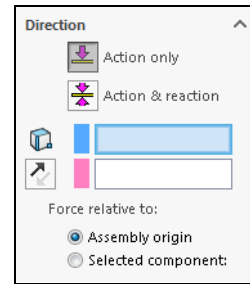

### Case 1

#### Direction of force is based on a fixed component.

If a fixed component is selected in the **Force Direction** box then the direction of the force will remain constant throughout the simulation.

Reference Fixed Component

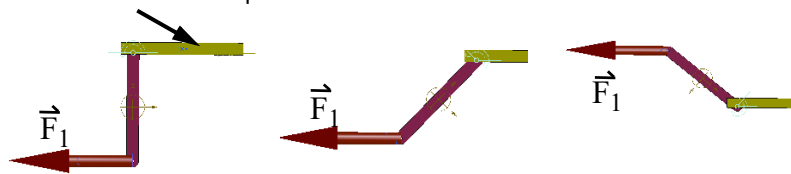

### Case 2

#### Direction of force is based on the selected moving component, which is also the component on which you want to apply the force.

If the part to which the force is applied is used as the reference datum, then the force will remain locked in its relative orientation to the body over the entire simulation time (i.e. it will stay in alignment with the geometry on the body used to define the direction).

Reference Rotating Component

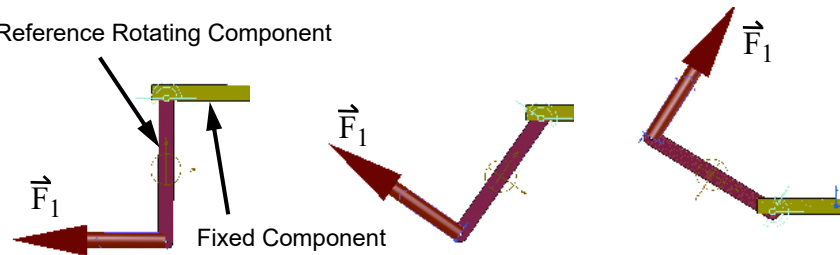

**Case 3**

**Direction of force is based on the selected moving component which is different from the component on which you want to apply the force.**

If another moving part is used as the reference datum, the direction of the force will change based on the relative orientation of the reference body to the moving body. This is hard to visualize easily, but if you apply the force on a body that is held locked in position, and use a rotating part as the reference datum, you should see the force rotate in concert with the reference body.

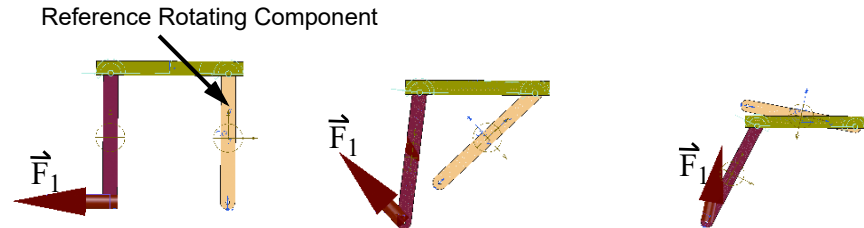
**Note**

Make sure that the gravity symbol shows the orientation in the negative Y direction.

**8 Create a force of 8900 N to simulate the weight of the car on the car jack.**

Click **Force** .

For **Type**, select **Force**.

Under **Direction**, select **Action Only**.

Under **Action Part and Point of Application of Action**, select the circular edge on component Support-1 (see image below).

For **Force Direction**, select the vertical edge on the Base-1 component.

**Note**

The default force direction is defined by the circular edge selected in the **Action Part and Point of Application of Action** field, i.e. perpendicular to the plane of the edge. Because the default direction is correct in this case, the edge selected in the **Force Direction** field is not required and is done solely for the educational purpose.

Under **Force Function**, select **Constant**. Enter a force value of **8900 N**.

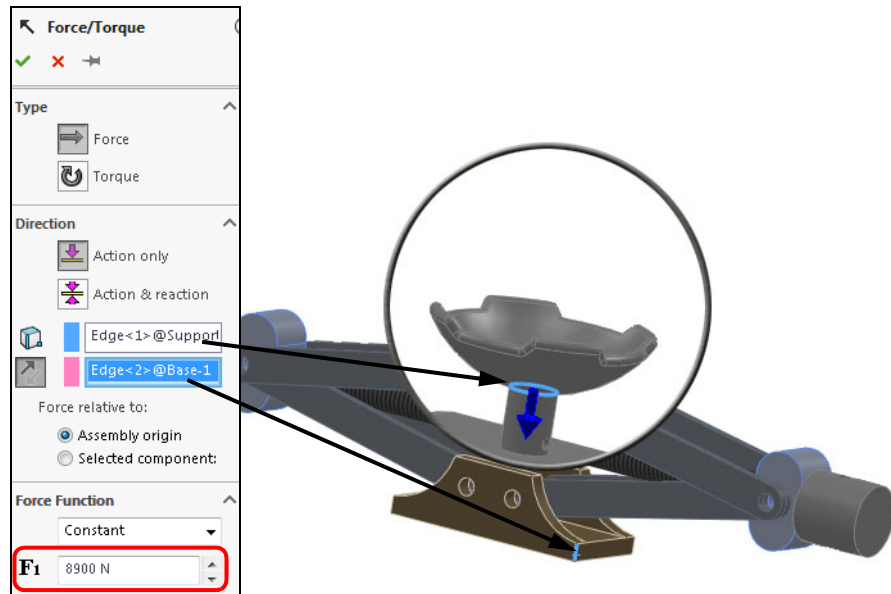

**Note**

Make sure that the force is directed downwards.

Click **OK** ✓.

**9 Run the Simulation.**

Click **Calculate** . The simulation will calculate for 5 seconds.

**10 Run the Simulation again for 8 seconds.**

Drag the end time key to 8 seconds on the timeline.

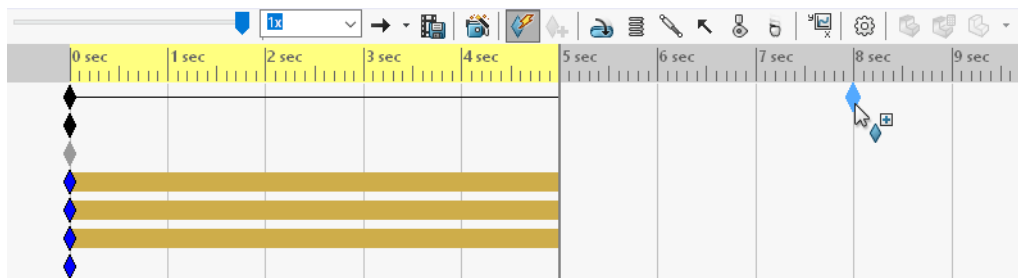

Click **Calculate** .

**Results**

The primary output from a motion study is a plot of one parameter versus another, usually time.

Once the motion is calculated plots can be created for a variety of parameters. All existing plots will be listed at the bottom of the MotionManager tree.

**Plot Categories**

Plots of the following categories can be created:

- Displacement
- Acceleration
- Momentum
- Power
- Velocity
- Forces
- Energy
- Other quantities

**Sub-Categories**

Within each of the categories, plots can be created for:

- Trace Path
- Linear Displacement
- Linear Acceleration
- Angular Velocity
- Applied Force
- Reaction Force
- Friction Force
- Contact Force
- Angular Momentum
- Angular Kinetic Energy
- Potential Energy Delta
- Pitch
- Roll
- Bryant Angles
- XYZ Position
- Linear Velocity
- Angular Displacement
- Angular Acceleration
- Applied Torque
- Reaction Moment
- Friction Moment
- Translational Momentum
- Translational Kinetic Energy
- Total Kinetic Energy
- Power Consumption
- Yaw
- Rodriguez Parameters
- Projection Angles

**Resizing Plots**

Plots can be resized by dragging any border or corner.

**Where to Find It**

- MotionManager toolbar: Click **Results and Plots** 

### 11 Plot the torque required to lift the weight of the car.

Click **Results and Plots** .

Under **Result**, select the category as **Forces**.

Under **Sub-category**, select **Motor Torque**.

Under **Result component**, select **Magnitude**.

Under **Select rotational motor object to create result**, select the motor that we created (see image below).

Click **OK** .

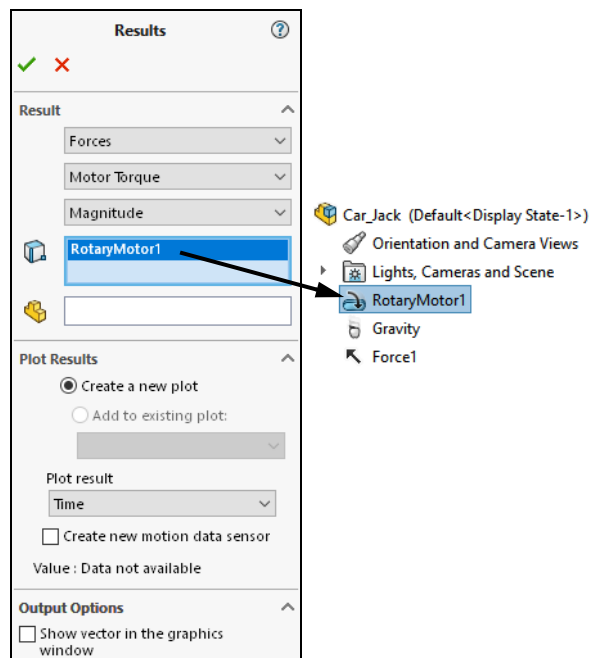

The plot of torque required appears in the graphics area.

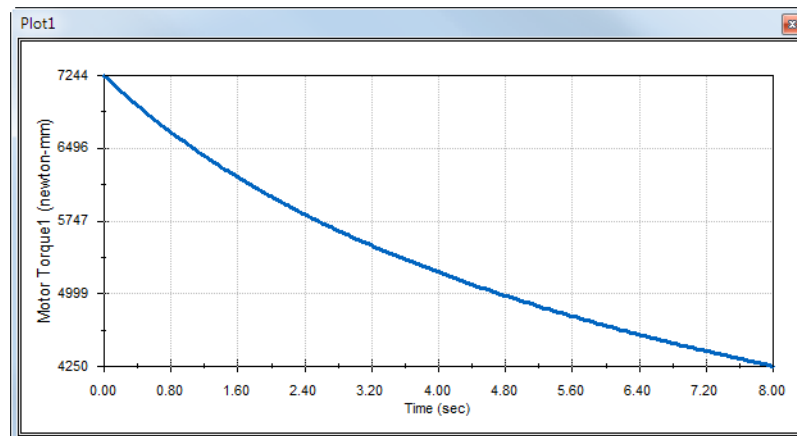

The required torque is about 7244 N-mm.

**Note**

Once the Rotary Motor1 is selected, a triad is displayed in the graphics area. This triad indicates the local X, Y and Z axes of the motor in which the output quantities may be displayed. In the present case we require the plot of the magnitude which is independent of the coordinate system. The post-processing is described in greater detail in the next lesson.

**12 Plot the power consumed to lift a weight of 8900 N.**

We will add this plot into an existing graph.

Click **Results and Plots** .

Under **Result**, select the category as **Momentum/Energy/Power**.

Under **Sub-category**, select **Power Consumption**.

Under **Select motor object to create result**, select the same motor that you selected in the previous step.

Under **Plot Results**, select **Add to existing plot** and select Plot1 from the pull down menu.

Click **OK** .

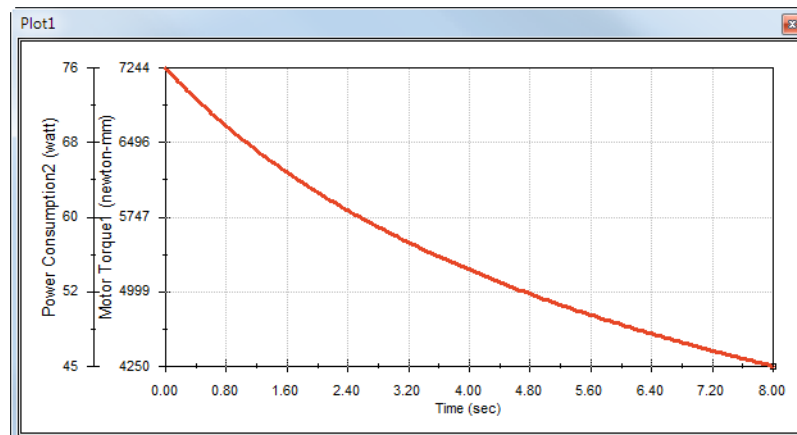
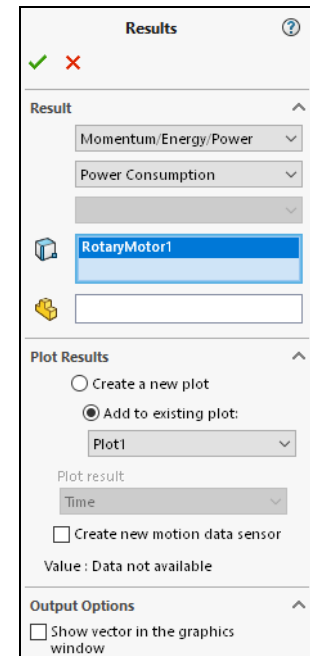

The power consumption is 76 Watts. Based on the torque and the power information, we can select an electric motor and use it to drive the Screw\_rod instead of a human hand.

### 13 Play animation.

Click **Play** ► .

The vertical time bar in both the MotionManager and the graph indicates the time.

Click **Stop** ■ .

### 14 Plot the vertical position of the Support.

Click **Results and Plots** .

Under **Result**, select the category as **Displacement/Velocity/Acceleration**.

Under **Sub-category**, select **Linear Displacement**.

For **Result Component**, select **Y-component**.

For **Select two points/faces**, select the top face of the support. If no second item is selected, the ground serves as the default second component, or the reference.

Leave the **Component to define XYZ directions** field empty. This indicates that the displacement is reported in the default global coordinate system.

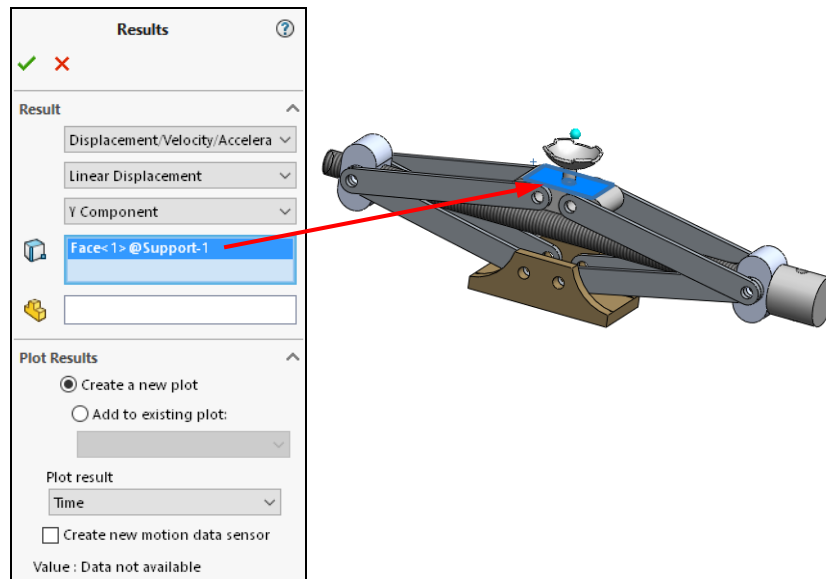

#### Note

The displacement is measured at the origin of the Support part file, indicated as the small blue sphere in the above figure, with respect to the origin of the Car\_Jack assembly file. The result is reported in the default global coordinate system.

Click **OK** ✓ .

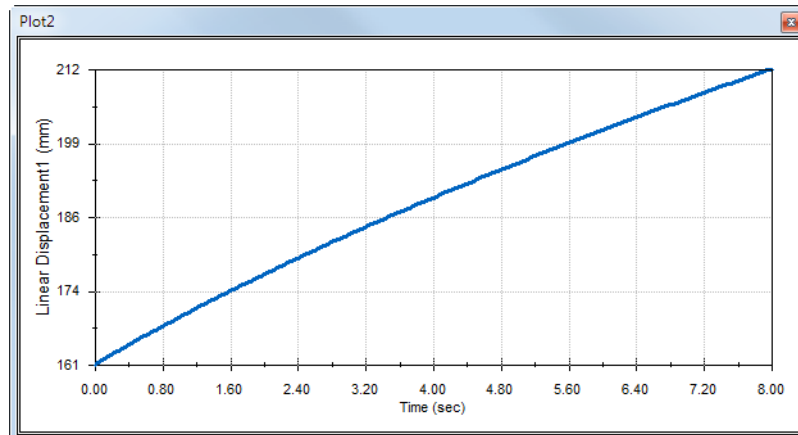

The above graph indicates change of the global Y coordinate of the origin of the Support part file. The displacement is therefore 51mm (212-161mm) in the positive global Y axis.

### 15 Modify the graph.

Modify the ordinate of the graph to show the angular displacement of the motor.

In the MotionManager tree, expand the Results folder. Right-click Plot2 and click **Edit Feature**.

Under **Plot Results**, select **New Result**.

For **Define new result**, select **Displacement/Velocity/Acceleration**.

Select **Angular Displacement** under sub-category.

Select **Magnitude** for result component.

Select RotaryMotor1 for the simulation element.

Click **OK** ✓ .

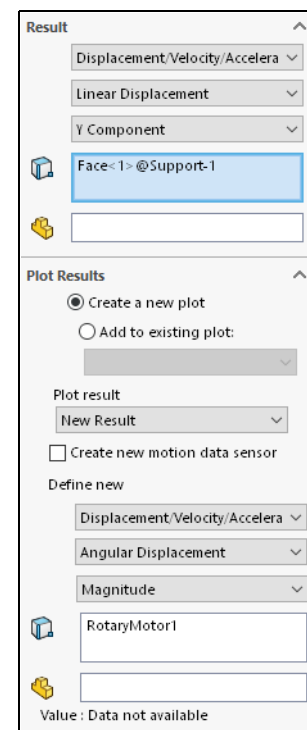

### 16 Examine the graph.

The result plot is a little coarse and the data ordinate does not cover the full range of -180 to 180 degrees. To generate a graph with finer detail, more data must be saved to disk.

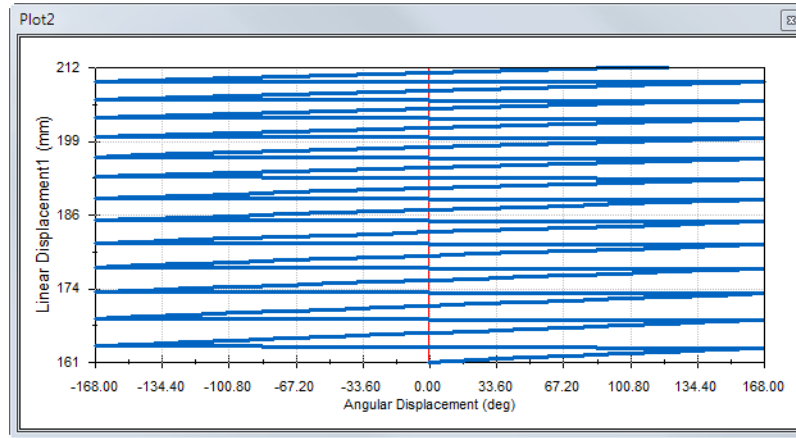

### Introducing: Study Properties

SOLIDWORKS Motion has its own set of properties to control the way the study is calculated and displayed.

Study properties will be discussed throughout the book.

### Where to Find It

- MotionManager toolbar: Click **Motion Study Properties**

### Introducing: Frames per Second

Frames per second controls how often the data is saved on the disk. The higher the frames per second, the more dense the data recorded.

### Where to Find It

- In the Motion Study Properties, expand Motion Analysis and either type the number, use the spinbox arrows or adjust the slider

### 17 Modify Motion Study properties.

Click **Motion Study Properties** .

Change the **Frames per second** to **100**.

Click **OK** .

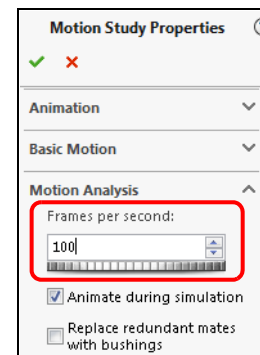

**18 Calculate the study.**

Click **Calculate** .

Notice that we have more detail and the angular displacement is nearly from -180 to 180 degrees.

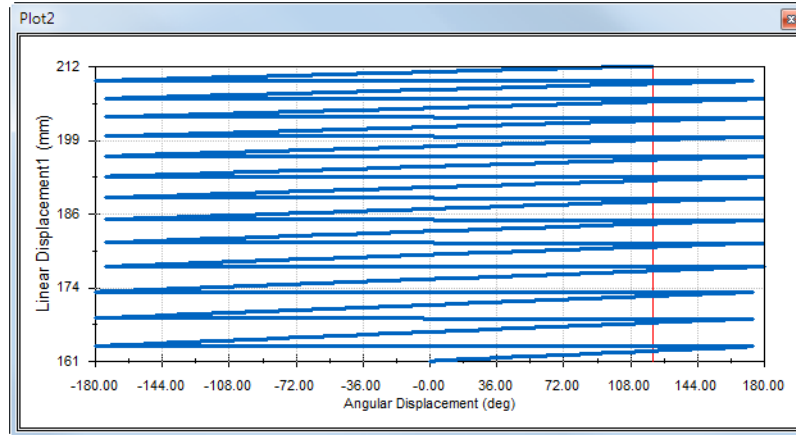
**19 Save and close the file.**

## Exercise 33: 3D Fourbar Linkage

This assembly is a simple mechanism called 3D Fourbar linkage. There are only four parts in the mechanism. The Support part is grounded, and the rotation of the Lever part will cause a sliding motion of the SliderBlock part.

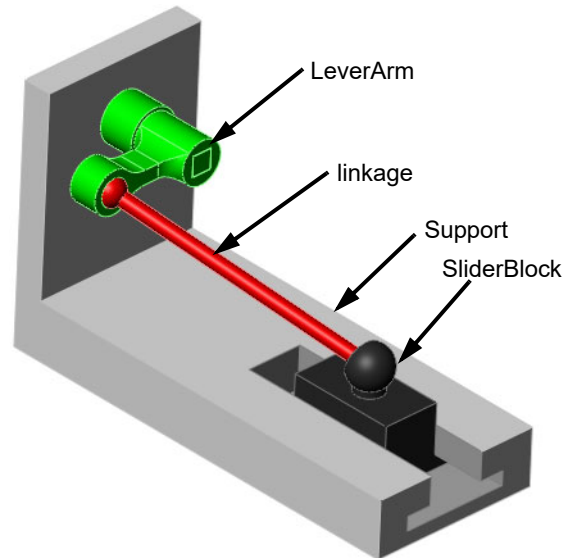

This exercise reinforces the following skills:

- *Basic Motion Analysis* on page 324
- *Results* on page 335

## Project Description

The LeverArm will be simply rotated with a constant 360 deg/sec angular velocity. Determine the amount of torque required to drive this mechanism and plot it from the motion simulation.

### 1 Open an assembly file.

Open 3D Fourbar linkage from the Lesson01 \ Exercises folder.

### 2 Verify fixed and moving components.

Make sure that support is fixed while the other components can move.

- ▶ (f) support<1> -> (Default<<Default>\_Display State 1>)
- ▶ (-) SliderBlock<3> (Default<<Default>\_Display State 1>)
- ▶ (-) LeverArm<1> (Default<<Default>\_Display State 1>)
- ▶ (-) linkage<1> (Default<<Default>\_Display State 1>)
- ▶ MateGroup1

### 3 Motion study.

In the MotionManager, select **Motion Analysis**.

The default Motion Study 1 will be used for the analysis.

### 4 Add gravity.

Apply gravity in the negative Z direction.

**5 Define motion of the Lever Arm.**

Define a Rotary Motor at **360 deg/sec**.

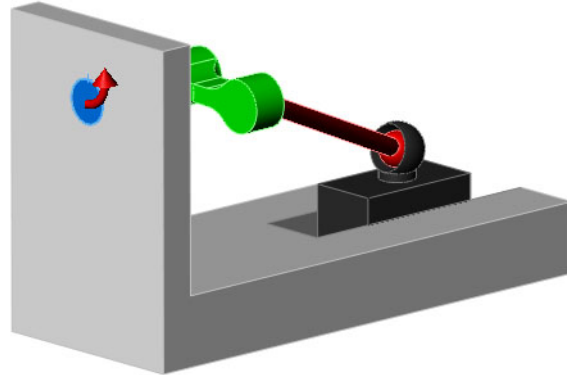
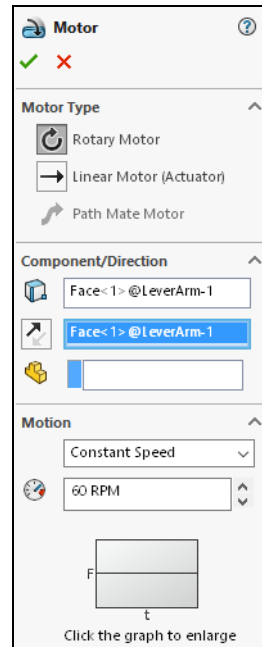
**Tip**

You can enter 360 deg/sec directly into the PropertyManager and it will automatically be converted to RPM.

**6 Motion study properties.**

Set the **Frames per second** to **100**.

Set the time key to **4 seconds**.

**7 Calculate the simulation.****8 Determine the torque and power required to drive the mechanism.**

Define a graph showing Motor torque and the required power as a function of time. Define both quantities in a single graph.

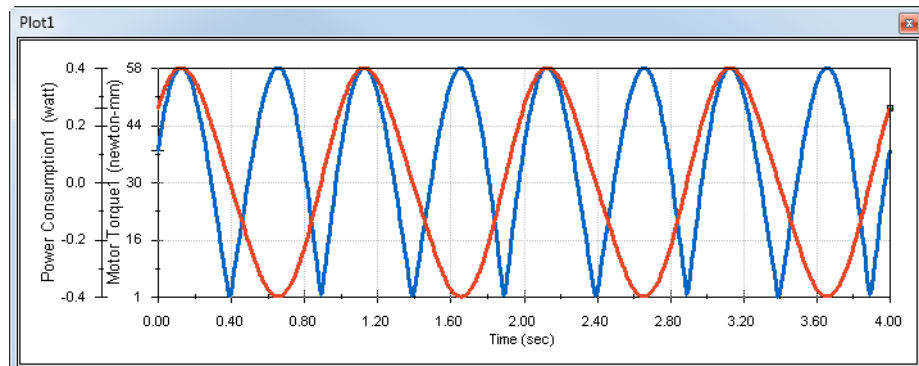

**9 Linear velocity of the SliderBlock.**

Plot a graph showing the linear velocity in the Y direction of the SliderBlock as a function of time.

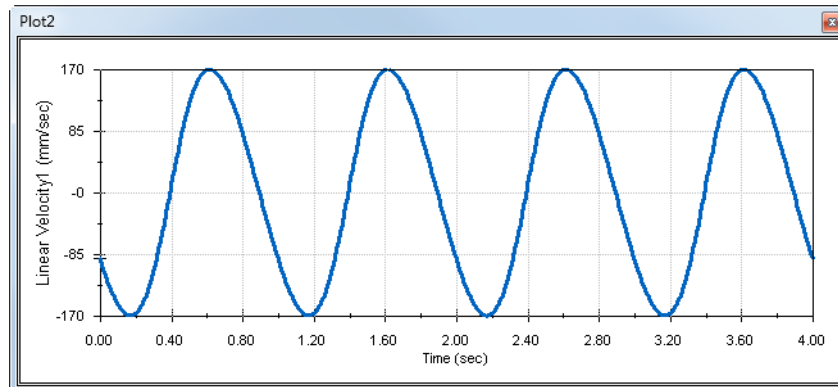

**10 Modify the graph.**

Modify the ordinate of the graph to show the angular displacement of the Rotary Motor. This way the graph will show the variation of the SliderBlock velocity relative to the angular displacement of the LeverArm.

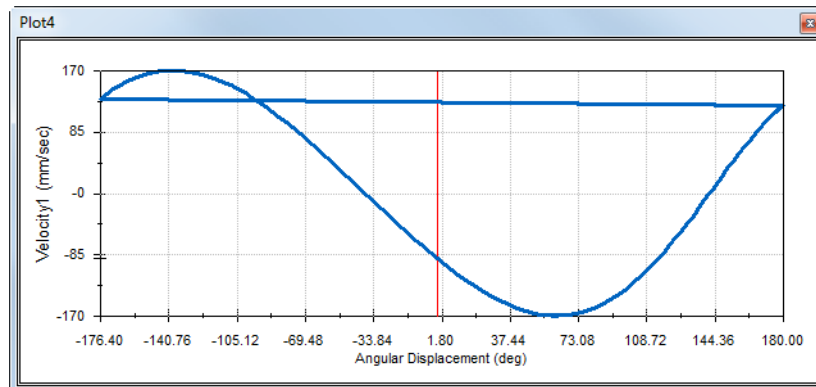

**11 Save and close the file.**

# Lesson 9

## Creating a SOLIDWORKS Flow Simulation Project

### Objectives

Upon successful completion of this lesson, you will be able to:

- Understand the model preparations required for a Flow Simulation Project.
- Create simple lids.
- Check the geometry for invalid contacts.
- Calculate the internal volume.
- Create a SOLIDWORKS Flow Simulation Project using the Project Wizard.
- Apply flow boundary conditions.
- Apply Goals.
- Run an analysis.
- Use the Solver Monitor window.
- View the results.

## Case Study: Manifold Assembly

In this lesson, we will learn how to set up a SOLIDWORKS Flow Simulation project using the Wizard. Prior to setting up our project, we will learn how to properly prepare our model for the analysis. We will run the simulation and learn how to interpret the results. In addition, we will see the many options available when post-processing the results.

## Problem Description

Air enters an intake manifold assembly at  $0.05 \text{ m}^3/\text{s}$  and flows out through the six openings as seen in the figure. The common goal of intake manifold design is even distribution of the combustion mixture to the piston heads. This will insure optimum engine efficiency. We will keep this in mind when analyzing our intake assembly.

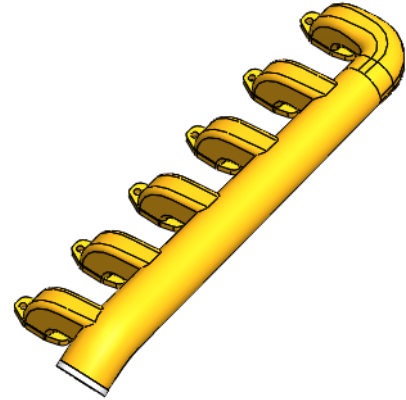

The objective of this lesson is to introduce the complete set up of a SOLIDWORKS Flow Simulation project within SOLIDWORKS, from model preparation to post-processing. Study goals will be defined and discussed. In addition, the results will be post-processed using the various options in SOLIDWORKS Flow Simulation.

## Stages in the Process

- **Prepare model for analysis.**  
Use the **Lids** tool to close the model in preparation for an internal analysis. The **Check Geometry** command will be used to make sure that your model is ready for a flow simulation.
- **Set up flow simulation.**  
Use the Wizard to set up the flow simulation project.
- **Apply boundary conditions.**  
Boundary conditions are applied to inlets and outlets.
- **Declare calculation goals.**  
Goals can be defined that are special parameters that the user will have information for after the analysis is run.
- **Run the analysis.**
- **Post-process the results.**  
The results can be processed using many available options in SOLIDWORKS Flow Simulation.

---

**1 Open SOLIDWORKS.****2 SOLIDWORKS Flow Simulation Add-Ins.**

Once installed, SOLIDWORKS Flow Simulation can be activated on SOLIDWORKS Add-Ins tab of the CommandManager.

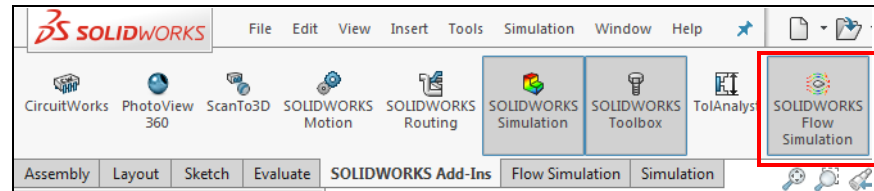
**Note**

Alternatively, add-ins can be activated using the **Tools, Add-Ins** menu.

**3 Open Assembly.**

Open Coletor from the Lesson01 \Case Study folder.

---

**Model Preparation**

In any static analysis, it is often necessary to modify the SOLIDWORKS geometry to allow the simulation to run. The same is true in flow simulations. SOLIDWORKS Flow Simulation groups flow analysis into two separate categories, internal analysis and external analysis. Before beginning model preparations, it is necessary to ask yourself which type of analysis you wish to perform.

**Internal Flow Analysis**

Internal flow analysis involves fluid flow bounded by outer solid surfaces, e.g. flows inside pipes, tanks, HVAC systems, etc. Internal flows are confined inside the SOLIDWORKS geometry. For internal flows the fluid enters a model through the inlets and exits the model through the outlets with the exception of some natural convection problems that have no openings.

To perform an Internal flow analysis, the SOLIDWORKS model must be fully closed (no openings) using lids. The **SOLIDWORKS Flow Simulation, Tools, Check Geometry** command tool can be used to ensure that the model is fully closed.

**External Flow Analysis**

External flow analysis involves a solid model which is fully surrounded by the flow, e.g., flows over aircraft, automobiles, buildings, etc. The fluid flow is not bounded by an outer solid surface, but bounded only by the Computational Domain boundaries and does not require a lid unless the application involves a flow source (such as a fan).

If both internal and external analysis is required simultaneously, e.g., flows over and through a building, the analysis is treated as an External analysis in SOLIDWORKS Flow Simulation.

## Manifold Analysis

Now that we know the difference between internal and external analysis, we can characterize our manifold analysis as internal. We will only study the flow on the inside of the manifold assembly and are not concerned with any flows around the body. As mentioned previously, to perform an internal flow analysis, the SOLIDWORKS model must be fully closed using Lids.

## Lids

Lids are used in internal flow analysis. In this type of analysis, all openings within a model must be covered using the SOLIDWORKS “lids” features. The surfaces of the lids (which contact the fluid) are used to apply boundary conditions which introduce a mass flow rate, volume flow rate, static /total pressure, or Fan condition within a fluid volume.



## Note

Situations that do not require the use of lids include external analysis that measure flow over bodies such as: cars, planes, buildings, ...etc. In addition, lids are not used in natural convection problems.

## Introducing: Create Lids

The **Create Lids** tool automatically creates lids for all openings in the selected planar surface of the model. This tool is available for both part and assembly files. The lids are necessary for an internal analysis (problems such as flow through a ball valve or pipe).

## Where to Find It

- CommandManager: **Flow Simulation > Create Lids** 
- Menu: **Tools, Flow Simulation, Tools, Create Lids**
- Flow Simulation Main toolbar: **Create Lids** 

---

### 4 Create a lid on the inlet face.

Under **Tools, Flow Simulation, Tools**, select **Create Lids** .

Select the annular face defining the plane of the inlet that should be closed by the lid.

In the **Create Lids** PropertyManager, click **Adjust Thickness**  and enter 1 mm as the **Thickness**.

Click **OK**.

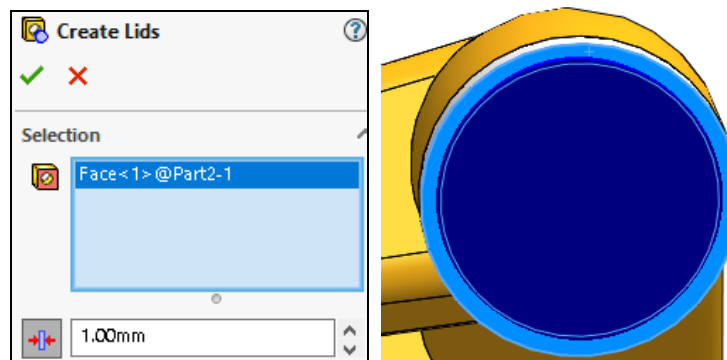

You'll notice that a new part called LID1 gets created in the FeatureManager design tree. The part is a blind extrusion from the selected planar face into the opening with a distance that was specified as the **Thickness**.

**Note** Multiple planar faces can be selected using the **Create Lids** tool. If the user is working with an assembly, new parts named LID1, LID2... will be created. If the user is working with a single part, new LID1, LID2...features will be created.

**Tip** It is good practice to rename your lids when working in an assembly. This can avoid problems with multiple assemblies with lids open at the same time.

---

### Lid Thickness

If necessary, the thickness of the lid can be adjusted by clicking the **Adjust Thickness** button  and input the value in the **Thickness** box (as done in the previous step).

The thickness of an external lid for an internal analysis is usually not important for the analysis. However, the lid should not be so thick that the flow pattern is affected downstream in some way. If this is both an external and internal analysis then creating a lid that is too thin will cause the number of cells to be very high. For most cases the lid thickness could be the same thickness used to create the neighboring walls.

### Manual Lid Creation

The **Create Lids** tool cannot be used if there are no planar faces to use as references. In this instance, the user must create the lids manually by creating lid parts or features.

### Adding a Lid to a Part File

- Click on the surface adjacent to where you would like to add the lid and open a sketch.
- Select the inside edge(s) and select **Sketch Tools, Convert Entities**.
- **Insert, Boss/Base, Extrude** and select the **Mid Plane** option.

**Note**

Selecting the **Mid Plane** option is very important. The **Blind** option would create an invalid contact (disjointed body) between the lid and the body. SOLIDWORKS Flow Simulation is unable to apply boundary conditions onto a surface when there is an invalid contact.

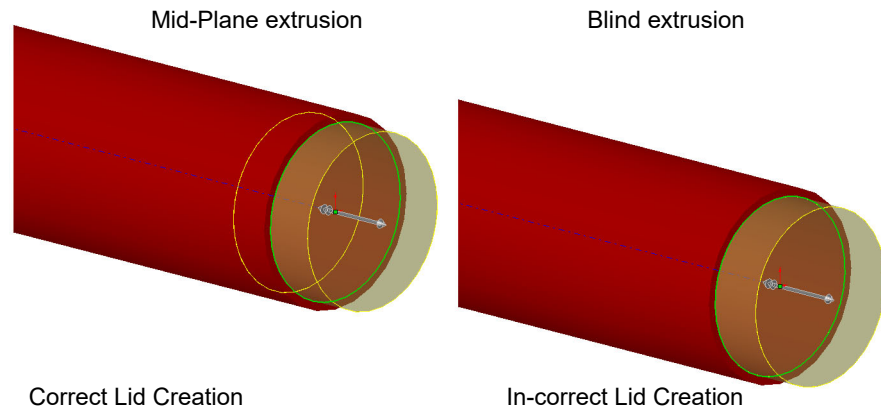

**Adding a Lid to an Assembly File**

There are several ways to create lids within a SOLIDWORKS assembly file. The following steps outline one of these recommended ways.

- Within the SOLIDWORKS assembly mode go to **Insert, Component, New Part**.
- Select the surface adjacent to where you would like to add the lid.
- Select the inside edge(s) and select **Sketch Tools, Convert Entities**.
- **Insert, Boss/Base, Extrude** and select the **Mid Plane** option.
- Click **OK** to close the part edit mode. A new Part will be added to the assembly.

**Note**

It's usually a good idea to create the lids as a part file within an assembly especially if your analysis involves heat transfer. These lids can then be assigned a different material, such as an insulator so that the lid does not affect the heat transfer analysis.

---

---

### 5 Remaining lids.

Create the remaining lids on the outlet faces using the manual lid creation method described above. Use a **Mid Plane** extrusion of 2 mm.

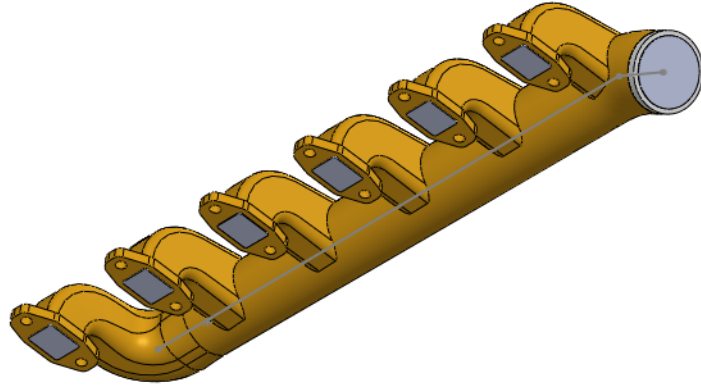

#### Note

We could have used the **Create Lids** tool to create the remaining lids, however the tool would have closed all of the openings on the selected face, therefore closing the bolt holes. This is not necessary, and this also gives us the opportunity to practice manual lid creation.

---

---

#### Discussion

When creating lids before the analysis, keep in mind that they have two purposes; closing off any openings and allowing for solid geometry on which boundary conditions (i.e. static pressure, mass flow rate, etc.) are defined. In this model, we could have used a single part to close off all six outlet ports as shown in the figure. This type of lid would not be applicable if we required different boundary conditions on each outlet. In addition, this lid is inappropriate because to evaluate the design, we require information about the flow through each individual outlet (remember, a well designed manifold will distribute the combustion mixture evenly). We will see that this type of lid will make it more difficult to obtain the information about each port.

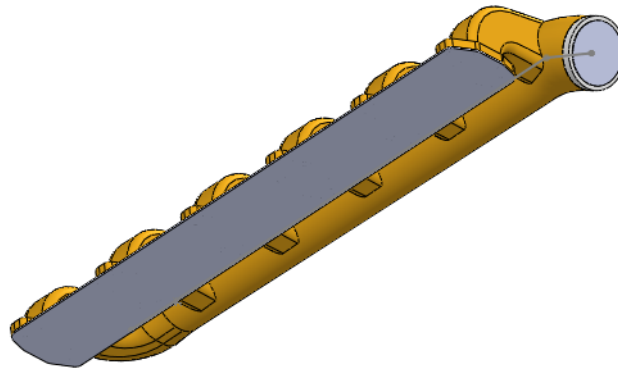

## Checking the Geometry

The SOLIDWORKS model must be checked to determine if there are any problems with the geometry that may cause problems meshing the body and fluid regions.

There are two main reasons that prevent meshing of the solid and fluid bodies.

- Openings in the geometry that prevent SOLIDWORKS from fully defining a fully closed internal volume. This is for an internal analysis only.
- Invalid contacts exist between parts in an assembly. (An invalid contact is defined as a line or point contact between part files.) These will be discussed later in the lesson.

### Note

Invalid contacts affect both internal and external analysis.

### Introducing: Check Geometry

A SOLIDWORKS Flow Simulation tool called **Check Geometry** allows users to check the SOLIDWORKS geometry. This tool also allows you to check bodies for possible geometry problems (e.g., tangent contact) that cause SOLIDWORKS Flow Simulation to create an inadequate mesh.

The **State** field allows you to disable some of the assembly components from the geometry check.

**Create solid body assembly** and **Create fluid body assembly** options are used to create part files of solid and fluid regions respectively. These part files help verify that the software has created the correct fluid and solid regions.

The **Check Geometry** tools allow you to create a solid and fluid body when **Improved geometry handling** mode is activated.

Provided the fluid volume exists, **Show Fluid Volume** command will graphically indicate it.

The **Check** command will run the geometry check on the assembly.

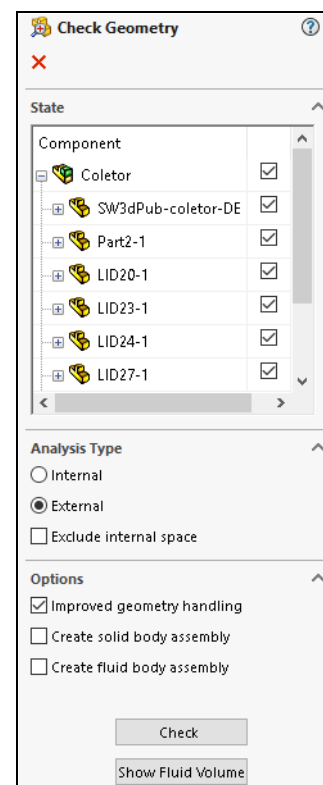

### Where to Find It

- CommandManager: **Flow Simulation > Check Geometry**
- Menu: **Tools, Flow Simulation, Tools, Check Geometry**
- Flow Simulation Main toolbar: **Check Geometry**

**6 Check for invalid fluid geometry.**

Access **Check Geometry** tool.

Keep all assembly components selected.

Under **Analysis Type**, select **Internal**.

Click **Check**.

The results are presented in the text field below the graphics area.

The non-zero values for the fluid and solid volumes indicate that the internal fluid volume is water tight and suitable for flow simulation.

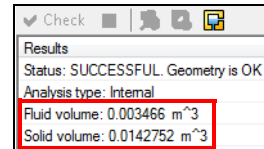

**Close** the text area with the results, and the **Check Geometry** PropertyManager.

**Note**

The **Check Geometry** command will check for possible invalid contacts, e.g., tangency, zero thickness, etc. If a problem has been detected, the message appears in the **Invalid contacts** output box.

**Tip**

When the geometry is deemed ready for analysis, it is good practice to set all components as fixed. This insures that none of the components move when defining boundary conditions, etc.

**Internal Fluid Volume**

SOLIDWORKS Flow Simulation will also calculate the total volume of solid components and the total fluid volume.

For internal flow analysis, the internal fluid volume must be greater than zero. If there are no invalid contacts and the internal fluid volume is still zero, then there is a small gap or an opening that connects the internal domain to the external space. Once the small gap or opening is detected and corrected, rerun the **Check Geometry** tool to ensure that the internal fluid volume is greater than zero.

**Invalid Contacts**

If invalid contacts exist, SOLIDWORKS Flow Simulation will not be able to calculate an internal fluid volume (within the computational domain), and the **Check Geometry** tool will report the internal fluid volume to be zero even if the model is perfectly closed and has no openings or gaps. Invalid contacts must be fixed before a flow analysis can be performed.

The invalid contacts can be fixed by either separating the two parts with a very small distance so that they are no longer touching, or by creating an interference fit between the two parts.

### Invalid Contact Examples

Some typical types of invalid contact are shown in the figure.

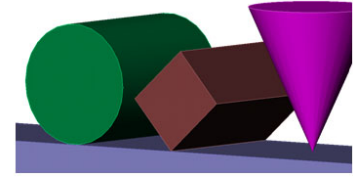

In our example, if a **Blind** extrusion was used, an invalid line contact would be created as shown in the figure.

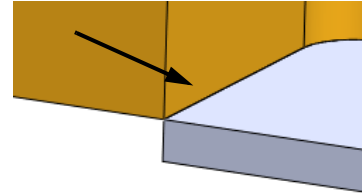

If an invalid contact is detected, you may click the contact in the list of invalid contacts to show the location.

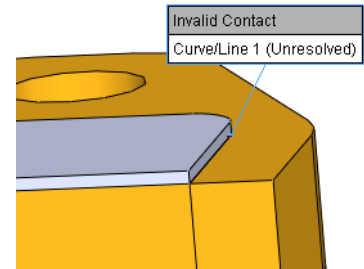

### Note

Not every tangent contact causes an invalid contact. SOLIDWORKS Flow Simulation uses SOLIDWORKS API boolean operations to compute fluid and solid bodies. If SOLIDWORKS is able to construct the resulting bodies successfully, then SOLIDWORKS Flow Simulation will consider the bodies as valid for its analysis even with potentially bad contacts, like “line contact.”

In some models, even with invalid contacts the user will be able to apply boundary conditions and solve the analysis. Users in these cases may receive the **Failed to complete** error message when trying to define **Cut Plots**. The user would have to correct the invalid contact to plot and rerun the analysis before defining Cut Plot images.

### Important!

For internal flow analysis, boundary conditions can not be applied until all openings are closed.

**7 Modify lid position.**

To demonstrate lid positions that are not ideal, you will now change the position of the last lid. Edit the position of the last lid so that its internal edge forms a line contact along the edge of the outlet.

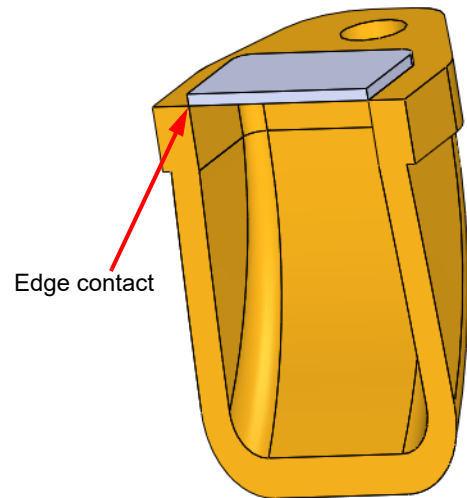
**8 Check Geometry.**

Follow step 6 on page 353 to check geometry for invalid contacts. Make sure you specify **Internal** analysis type.

The result text window indicates 16 detected unresolved contacts, which were fixed.

Because the invalid contacts were fixed, the **Check Geometry** tool was also able to calculate both the fluid and solid volumes.

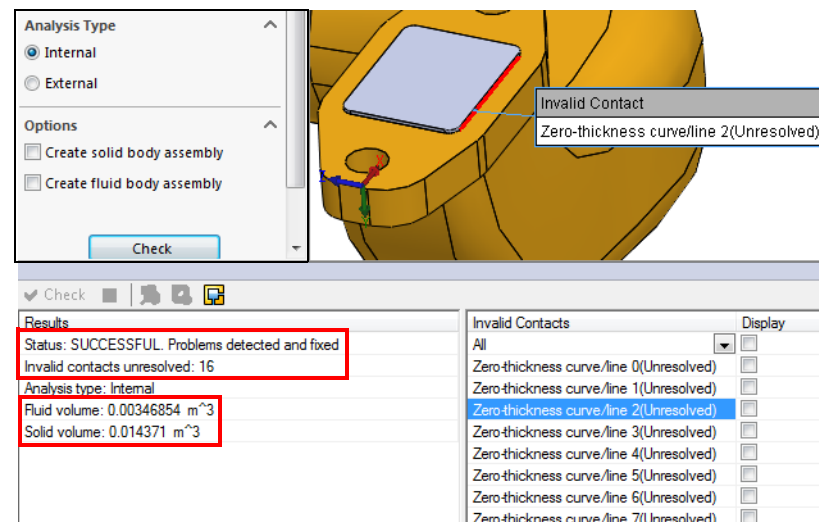
**Note**

In most of such situations, software is able to heal invalid contact and calculate the fluid and solid volumes.

Click on any of the invalid contacts to see it in the graphics area.

**Close** the text area with the results, and the **Check Geometry** PropertyManager.

- 9 Modify lid position again.**  
Follow step 7 and change the position of the lid to form a clear gap between the lid and the outlet.

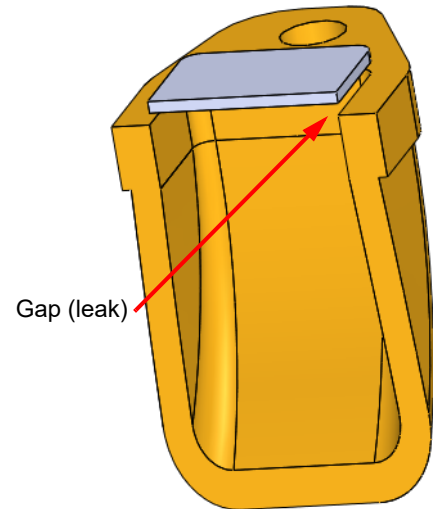

- 10 Check Geometry.**  
Follow step 8 to check the geometry for invalid contacts. Make sure you specify **Internal** analysis type.

The result text window indicates that the geometry check failed. Both the solid and fluid volumes show zero volumes indicating that they could not be calculated.

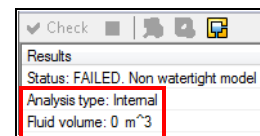

---

### Introducing: Leak Tracker

Leaks in geometry are sometimes difficult to detect. Leak tracker tool makes this task easy.

### Where to Find It

- Menu: **Tools, Flow Simulation, Tools, Leak Tracking**
- Flow Simulation Main toolbar: **Leak Tracking**

- 
- 11 Leak tracker.**  
Go to **Tools, Flow Simulation, Tools** and select **Leak Tracking** .

Select one face on the inside of the manifold, and one face on the outside of it.

Click **Find Connection**.

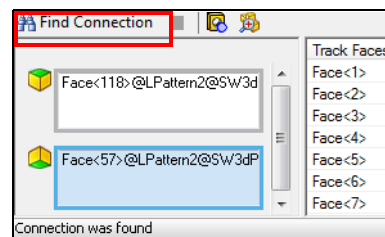
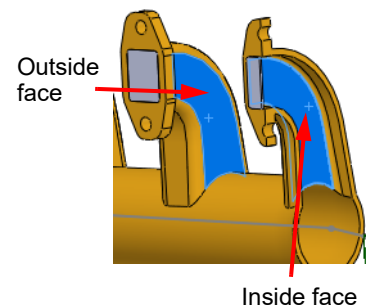

The trajectory from the inside face to the outside face will be graphically shown on the model.

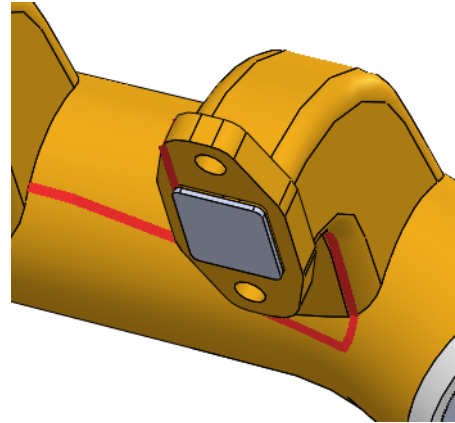

### 12 Close Leak Tracer.

### 13 Modify lid position.

Return the lid to its correct position where it forms the face to face contact with the outlet.

Face to face contact

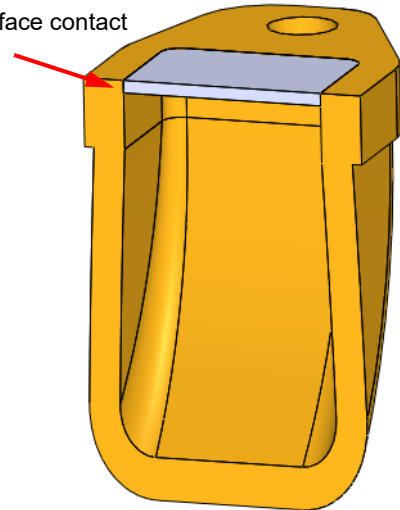

### Note

You may run the **Check Geometry** command for the last time to verify that your geometry is water tight.

---

---

## Project Wizard

Project wizard is the most convenient way to create and specify the basic configuration of your simulation project.

### Introducing: Wizard

The flow simulation project **Wizard** is used by even the most experienced users of SOLIDWORKS Flow Simulation. It walks you through the basic steps of setting up a flow analysis. Additional commands may then be needed to complete the definition of more complicated analyses. The Wizard addresses the following parts of modeling:

- **Project Configuration**

Select the configuration that you want to use with the simulation. You can create a new configuration or use one that is currently defined. It is recommended that you associate each flow simulation project to a new configuration. This insures that your files and results will be organized.

- **Unit System**

Defines the unit system that will be used in the simulation. This can be changed after finishing the Wizard in the **Flow Simulation** menu by selecting **Units**. In addition, each custom defined unit systems can be created that mix and match from the different universal systems.

- **Analysis type**

The analysis is defined as internal or external. In addition other features about the analysis can be defined (i.e., reference axis).

- **Default Fluid**

Defines the default fluid that is used in the analysis as well as the type of flow it will encounter (i.e., laminar, turbulent, both).

- **Wall Conditions**

Defines the boundary conditions for the flow at the walls of the SOLIDWORKS geometry.



- **Initial Conditions**

Defines the initial and ambient conditions of the solids and fluids in the model.

- **Results and Geometry Resolution**

Can define the density of the mesh based on the geometrical features of the model (thickness of thin wall and gaps) as well as the overall result accuracy.

### Where to Find It

- CommandManager: **Flow Simulation > Wizard** 
- Menu: **Tools, Flow Simulation, Project, Wizard**
- Flow Simulation Main toolbar: **Wizard** 

**14 Create a project using a wizard.**

From the **Tools, Flow Simulation** menu, choose: **Project, Wizard** .

**15 Create a new project.**

Under **Configuration**, click **Use Current** (default setting).

**Note**

You can also select **Create New** to create a new configuration, or **Select** to associate your project with any of the existing SOLIDWORKS configurations.

In the **Configuration Name** box, enter **Project 1**.

SOLIDWORKS Flow Simulation will store all data in a separate folder numbered sequentially, i.e. “1”, “2”, “3”,...etc. based on how many projects have been defined. This folder is located in the same directory as the assembly file.

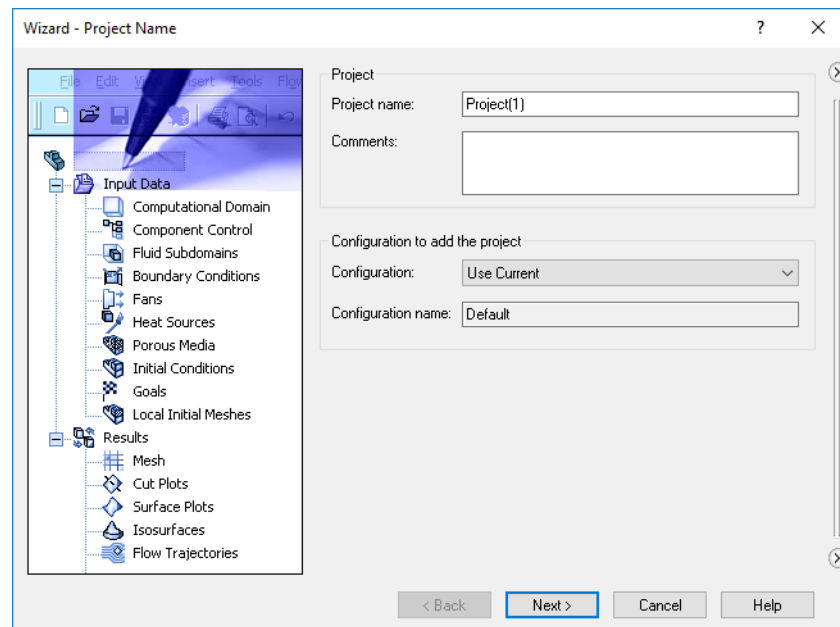

Click **Next**.

## 16 Select units.

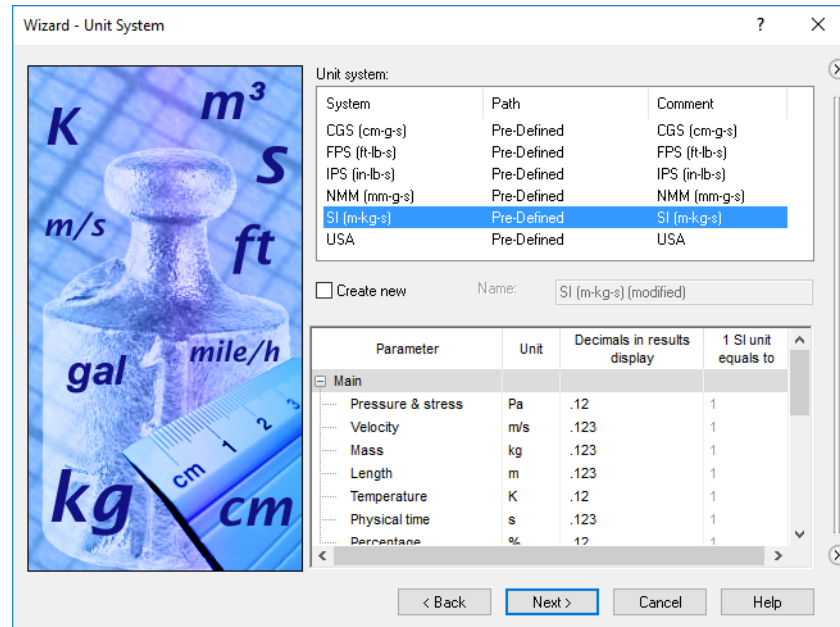

Select **SI (m-k-g-s)** as the **Unit System** for this project.

You can change the unit system anytime by going to **Tools, Flow Simulation, Units**.

Click **Next**.

### Note

You can also create your own system of units (by mixing and matching unit systems). This is done by checking the **Create New** check box and entering the custom name for the new unit system.

## 17 Select analysis type.

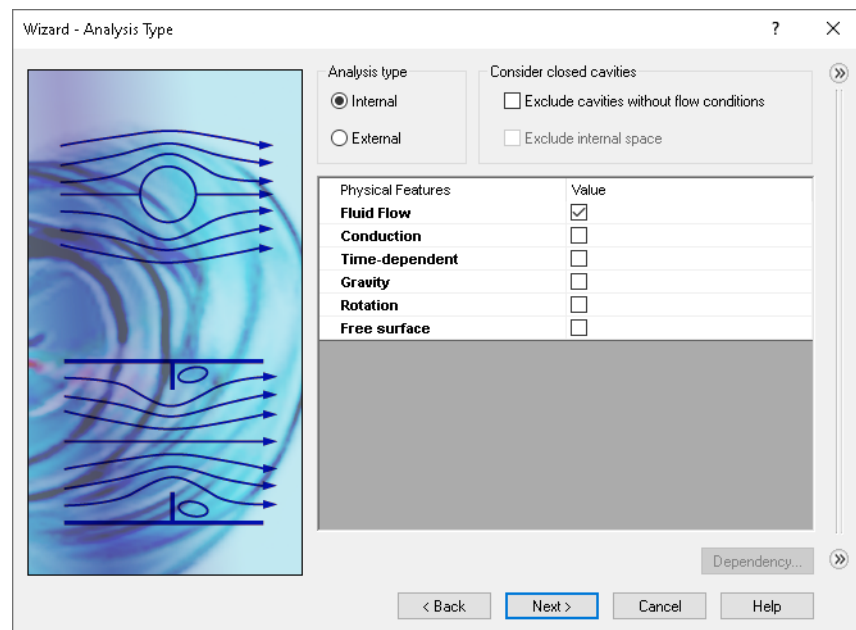

Select **Internal** under **Analysis Type**.

Under **Consider closed cavities**, clear **Exclude cavities without flow conditions**.

Accept all other default settings.

Click **Next**.

## Dependency

**Dependency** can be used to define the dependency of a specific quantity (i.e., radiation).

## Exclude Cavities Without Flow Conditions

The status of the **Exclude cavities without flow conditions** option is not important in this analysis; there is only one internal space within this model. If there were multiple unconnected internal spaces, then selecting this box would prevent SOLIDWORKS Flow Simulation from meshing and solving for any internal spaces that do not have boundary conditions.

## 18 Select fluid type (gas or liquid).

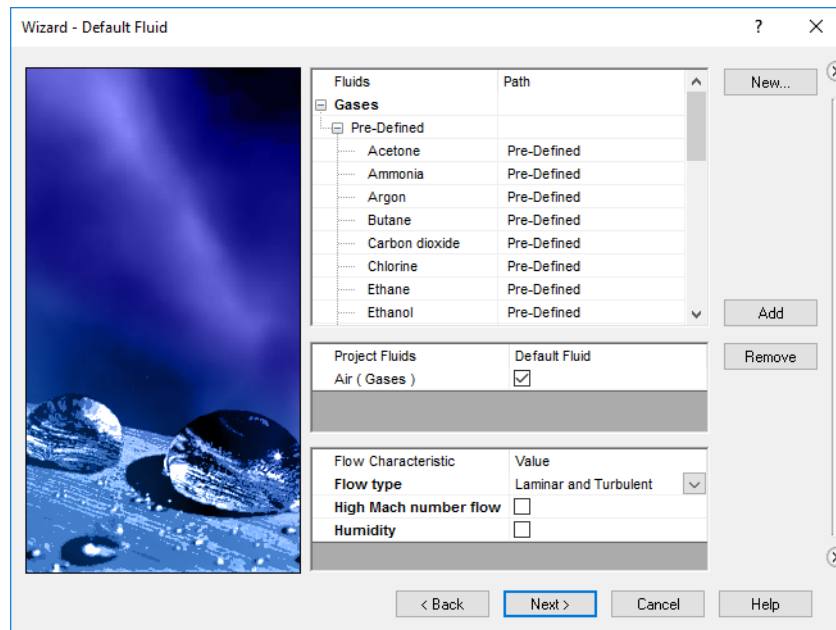

Expand the **Gases** tree. Using the scroll box in the database of fluids, click **Air**.

Click **Add**. This will move **Air** under the **Project Fluids** list.

Accept all other default settings.

Click **Next**.

## 19 Set wall conditions.

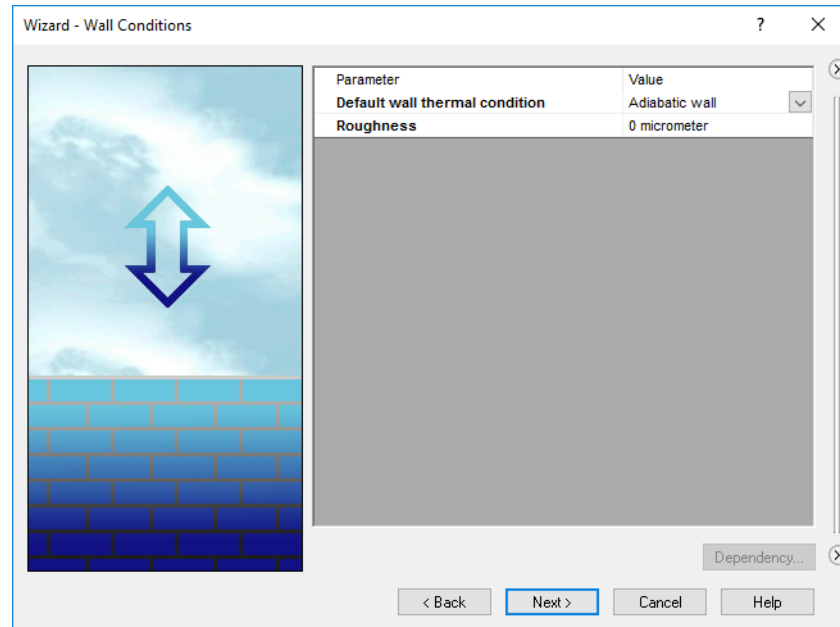

In the **Parameter** list, the value for **Default wall thermal condition** is **Adiabatic wall** and the value for **Roughness** is **0**.

Click **Next**.

---

### Adiabatic Wall

Since this project does not involve any type of heat transfer, the default **Adiabatic wall** selection is recommended. **Adiabatic wall** assumes the walls are perfectly insulated. In reality, there has to be some heat transfer across the wall. The manifold considered for the case study is an intake manifold of an engine. Air from the atmosphere will enter into the manifold at normal pressure and temperature therefore we will assume that the walls of the manifold are perfectly insulated.

### Roughness

This value is used in the calculation of the velocity profile within the boundary layer. If the default value of zero is used (recommended if the roughness is not known), the solver assumes the walls are smooth. Please consult the Flow Simulation help on how to determine appropriate roughness parameters.

## 20 Initial and ambient conditions.

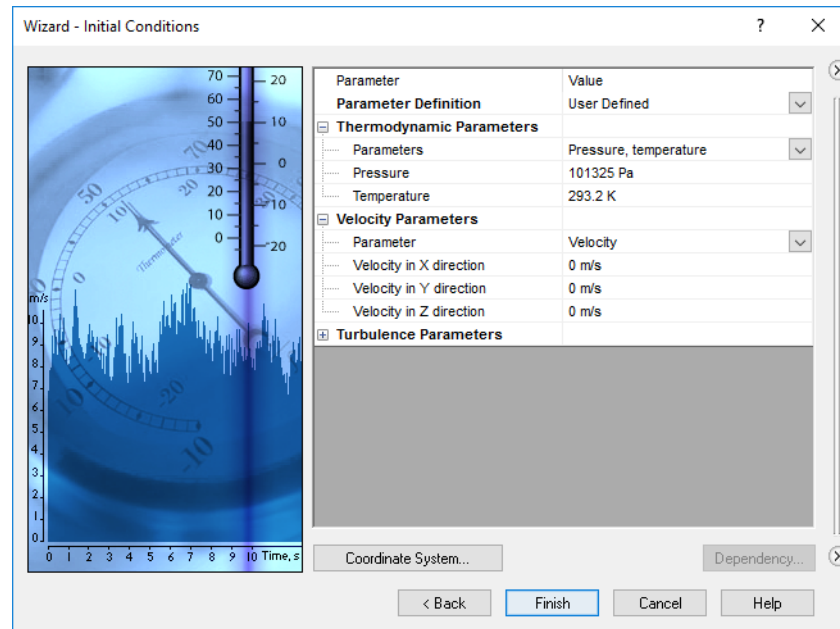

Click **Finish** to accept the default standard ambient conditions as the initial conditions for this analysis.

### Note

The closer the initial values are set to the final values determined in the analysis, the quicker the analysis will finish. Since we do not have any knowledge of the expected final values, we will not modify them in this lesson.

## 21 Review input data in the SOLIDWORKS Flow Simulation analysis tree.

SOLIDWORKS Flow Simulation will create a new project associated with the Default SOLIDWORKS configuration and a SOLIDWORKS Flow Simulation analysis tree will also be created.

The **Flow Simulation analysis tree** tab  in the SOLIDWORKS FeatureManager should be automatically created and selected.

If, after a later date, changes are needed to be made to the input data within the project, the user can right-click Input Data in the SOLIDWORKS Flow Simulation analysis tree and select the appropriate option to update the input information.

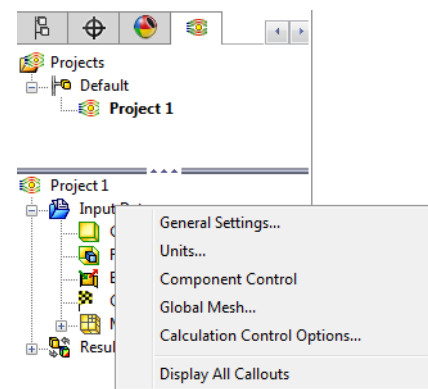

Expand the options under Input Data within the SOLIDWORKS Flow Simulation analysis tree. The SOLIDWORKS Flow Simulation analysis tree is used to define additional analysis settings for the project.

The Computational Domain, shown as a wireframe box enveloping the model, is used to visualize the volume being analyzed.

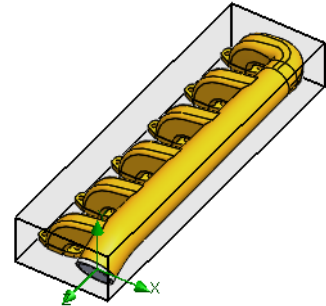

## Computational Domain

The Computational Domain is defined as a volume fixed with respect to a coordinate system within a fluid flow field. Although the fluid moves into and out of the computational domain, the computational domain itself remains fixed in space.

SOLIDWORKS Flow Simulation analyzes the model geometry and automatically generates a Computational Domain in the shape of a rectangular prism enclosing the model. The computational domain's boundary planes are orthogonal to the model's Global Coordinate System axes. For external flows, the computational domain's boundary planes are automatically distanced from the model capturing the fluid space around the model. However, for internal flows, the computational domain's boundary planes automatically envelop the model walls only.

## Introducing: Boundary Conditions

A boundary condition is required to describe where the fluid enters or exits the system (Computation Domain) and can be set as a pressure, mass flow, volume flow or velocity. Boundary conditions can also specify parameters of a wall such as ideal, stationary, or rotating.

The boundary condition can be entered in various ways allowing users to describe complex simulation scenarios.

- Constant: Boundary condition is entered as a constant value.

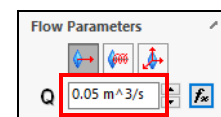

- **Formula: Formula Definition** allows for creation of dependence using mathematical and logical functions. The dependence can be on time (transient simulations only), on the monitored analysis outputs (such as outlet volume flow), on the defined analysis parameters, and on spatial coordinates. Most of the standard and advanced mathematical functions are supported. Logical function **IF** is supported along with the Boolean operators **AND**, **OR**, **XOR** and **NOT**.

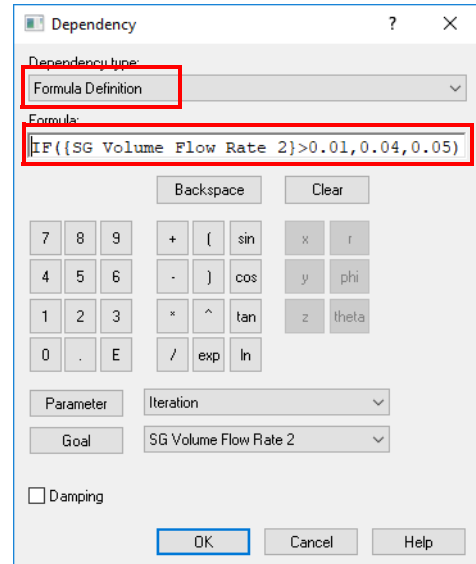

- **Table: Robust tabular dependencies** allow you to specify discrete dependencies of boundary conditions on spatial coordinates, on time (transient simulations only), on monitored analysis outputs (such as outlet volume flow rate), and on the defined analysis parameters. The list of exact available tabular dependencies can vary depending on the Flow Simulation feature and boundary condition used.

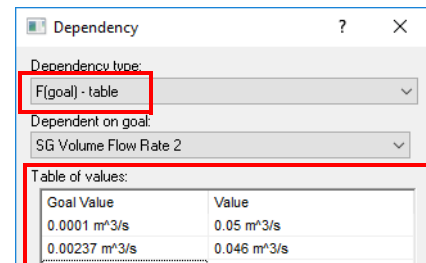

### Where to Find It

- **Shortcut Menu:** Right-click **Boundary Conditions** in the Flow Simulation analysis tree and click **Insert Boundary Condition**
- **CommandManager:** **Flow Simulation > Boundary Conditions**
- **Menu:** **Tools, Flow Simulation, Insert, Boundary Condition**

## 22 Insert boundary condition.

In the SOLIDWORKS Flow Simulation analysis tree, under Input Data, right-click Boundary Conditions and select **Insert Boundary Condition**.

Select the inside surface of the SOLIDWORKS feature representing the inlet, as shown in the figure.

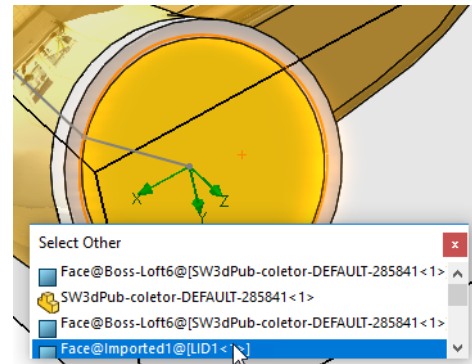

### Note

To access the inner face, right-click the outer face on the lid and click **Select Other**. In the **Select Other** window, cycle through the faces by moving the pointer to highlight each face dynamically in the solid geometry.

## 23 Set up the boundary condition.

In the **Boundary Conditions** PropertyManager, under **Type**, select the **Flow openings** button .

Still under **Type**, select **Inlet Volume Flow**.

Under **Flow Parameters**, click the **Normal to face** button  and enter 0.05 m<sup>3</sup>/s.

Click **OK**.

The new Inlet Volume Flow 1 item appears in the SOLIDWORKS Flow Simulation analysis tree under Boundary Conditions. SOLIDWORKS Flow Simulation will apply a 0.05 m<sup>3</sup> of air per second across the inlet area, normal to the selected face.

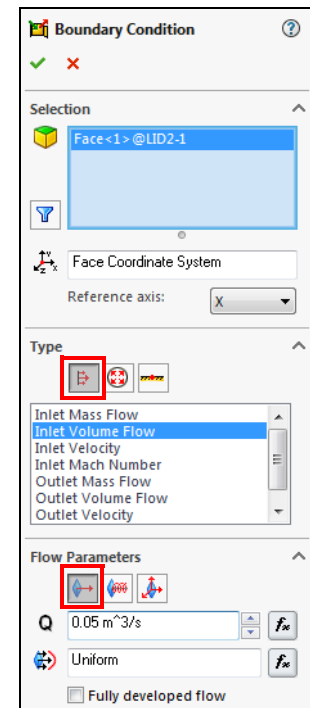

### Note

Since the volume flow rate is required as an output at each outlet, a pressure condition should be used to identify the outlet condition. If the pressure is not known at the outlet of each port, an ambient static pressure condition can be used as the boundary condition across each outlet face for this analysis.

**24 Insert boundary condition.**

In the SOLIDWORKS Flow Simulation analysis tree, under Input Data, right-click the Boundary Conditions icon and select **Insert Boundary Condition**.

Select the inner face of one of the outlet ports.

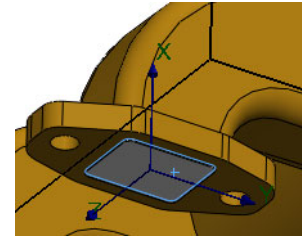
**25 Set up the boundary condition.**

In the **Boundary Conditions** window, under **Type**, select the **Pressure openings** button .

Still under **Type**, select **Static Pressure**.

Click **OK** to accept the default ambient values.

The new Static Pressure1 item appears in the SOLIDWORKS Flow Simulation analysis tree.

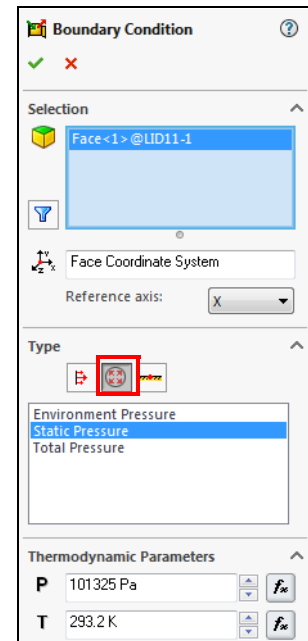
**26 Create additional outlet boundary conditions.**

Each outlet port should have a static pressure boundary condition assigned to the inside outlet lid surface. Create five additional static pressure boundary conditions for the remaining five outlets.

**Introducing:  
Engineering Goals**

SOLIDWORKS Flow Simulation contains built-in criteria to stop the solution process. However, it is best to use your own criterion by using what SOLIDWORKS Flow Simulation calls **Goals**. You can specify the Goals as physical parameters at areas of interest in the project, so that their convergence can be considered as obtaining a steady state solution from the engineering viewpoint.

Engineering goals are user specified parameters of interest, which the user can display while the solver is running and obtain information about after convergence is reached. Goals can be set throughout the entire domain (**Global Goal**), in a selected area (**Surface Goal**, **Point Goal**), or within a selected volume (**Volume Goal**). Furthermore, SOLIDWORKS Flow Simulation can consider the average, minimum or maximum value when examining goals.

In addition, you can also define an **Equation Goal**, which is a goal defined by an expression (basic mathematical functions) using the existing goals as variables. This allows you to calculate a parameter of interest (e.g., pressure drop) and keeps this information in the project for later reference.

There are five different types of goals that can be defined in SOLIDWORKS Flow Simulation:

- **Global Goal**
- **Surface Goal**
- **Equation Goal**
- **Point Goal**
- **Volume Goal**

**Where to Find It**

- Shortcut Menu: Right-click **Goals** in the Flow Simulation analysis tree and click **Insert Goals**
- CommandManager: **Flow Simulation > Goals** 
- Menu: **Tools, Flow Simulation, Insert**

**Use in Instructions**

Choose the type of goal you want to define.

**27 Insert surface goal.**

In the SOLIDWORKS Flow Simulation analysis tree, right-click **Goals**, and select **Insert Surface Goals**.

To select the inlet surface for the surface goal, split the feature pane and in the upper portion click the boundary condition **Inlet Volume Flow 1** item in the SOLIDWORKS Flow Simulation analysis tree to input the face where the surface goal is to be applied.

In the **Parameter** list, locate **Volume Flow Rate** and click the check box next to it.

Click **OK**.

The new **SG Volume Flow Rate1** item appears in the SOLIDWORKS Flow Simulation analysis tree under **Goals**.

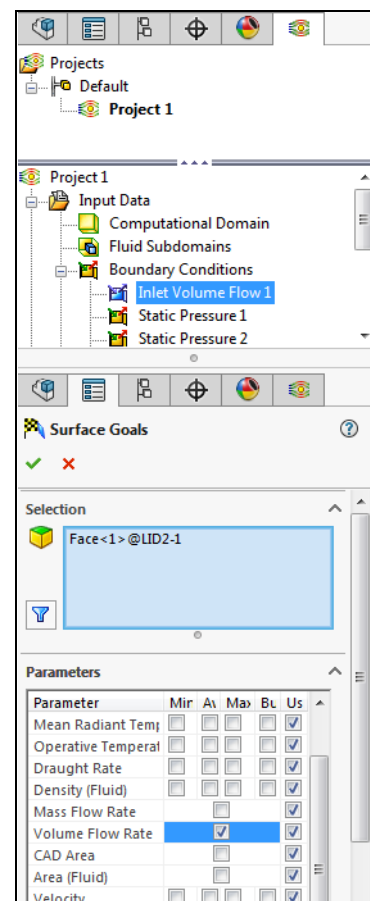

**28 Rename surface goal.**

Rename the SG Volume Flow Rate1 in the SOLIDWORKS Flow Simulation analysis tree so that it appears as Inlet SG Volume Flow Rate.

**29 Insert surface goal.**

Repeat the earlier steps 27 and 28 to apply a surface goal for the volume flow rate at the outlet ports.

When selecting the Static Pressure boundary conditions, hold the control key and select all of the outlet boundary conditions.

Click the **Create goal for each surface** check box. This will create 6 surface goals for each of the 6 outlets.

Optionally, rename each surface goal to reflect the outlet port.

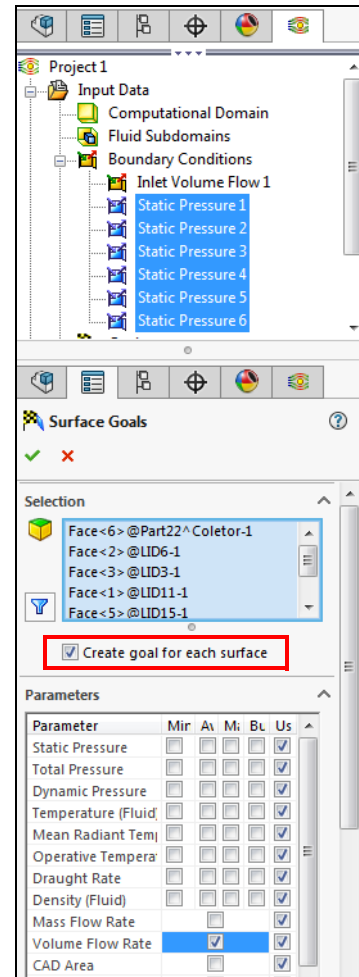
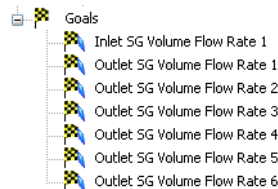

### 30 Insert equation goal.

The **Equation Goal** is used in this lesson to sum the outlet volume flow rates. The **Equation Goal** will determine the total **Volume flow rate** leaving the manifold.

In the Flow Simulation analysis tree, right-click the Goals icon and select **Insert Equation Goal**.

Select the Outlet SG Volume Flow Rate1 surface goal from SOLIDWORKS Flow Simulation analysis tree to add it to the **Expression** box.

Click **+** in the **Equation Goal** window.

Repeat the last 2 steps to add each of the remaining 5 outlet flow rates to complete the equation.

In the **Dimensionality** list, select **Volume Flow Rate**.

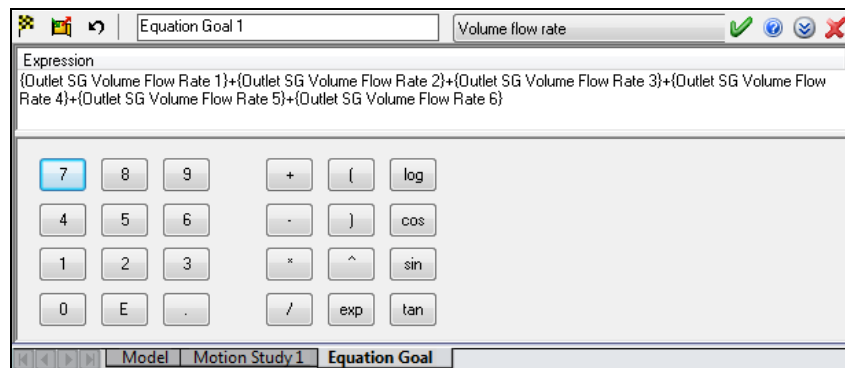

Click **OK**.

### 31 Rename the equation goal.

Rename the equation goal to Sum of outlet flow rates.

Once the solution has converged, the sum of the outlet volume flow rates should approximately be equal to the inlet volume boundary condition.

**Mesh**

Density and quality of mesh influences the result resolution, or in other words the level of accuracy of the results. In general, to achieve higher level of result accuracy, the finer mesh is in general required which means higher total cell counts and increased physical RAM requirements.

Higher mesh density will require longer CPU time to solve. Thus, the optimum mesh density requires a balance between precise results and computation time.

**32 Set initial global mesh parameters.**

In the SOLIDWORKS Flow Simulation analysis tree, under Input Data, expand the Mesh folder, right-click Global Mesh and select **Edit Definition**.

Under **Type** keep **Automatic**.

Under **Settings** accept the default **Level of initial mesh** of **3**.

Click **OK**.

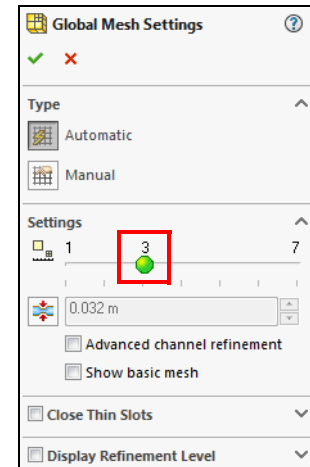
**Note**

In some situations, entering values for the **Minimum gap size** is important and ensures that any small gaps are not ignored during meshing. Since this model has a fairly uniform diameter, no minimum gap is required.

**33 Save file.**

Click **File, Save** to save the assembly file.

**Introducing: Run**

The **Run** command solves the simulation.

**Where to Find It**

- Shortcut Menu: Right-click the project folder (Project 1) in the SOLIDWORKS Flow Simulation analysis tree and click **Run**
- CommandManager: **Flow Simulation > Run** 
- Menu: **Tools, Flow Simulation, Solve, Run**

**Load Results Option**

Because the results from SOLIDWORKS Flow Simulation may become large, it is necessary to Load them for post-processing. This option automatically loads SOLIDWORKS Flow Simulation results once the solver completes.

**Note**

If multiple configurations/solutions are obtained, only a single solution set can be loaded at a time. Before loading a new set of results, the currently loaded results must be unloaded.

## Monitoring the Solver

The solution monitor window will appear after the solver has started. On the left of the **Solver** window is a log of each step taken in the solution process. On the right is an information dialog box with mesh information and any warnings concerning the analysis.

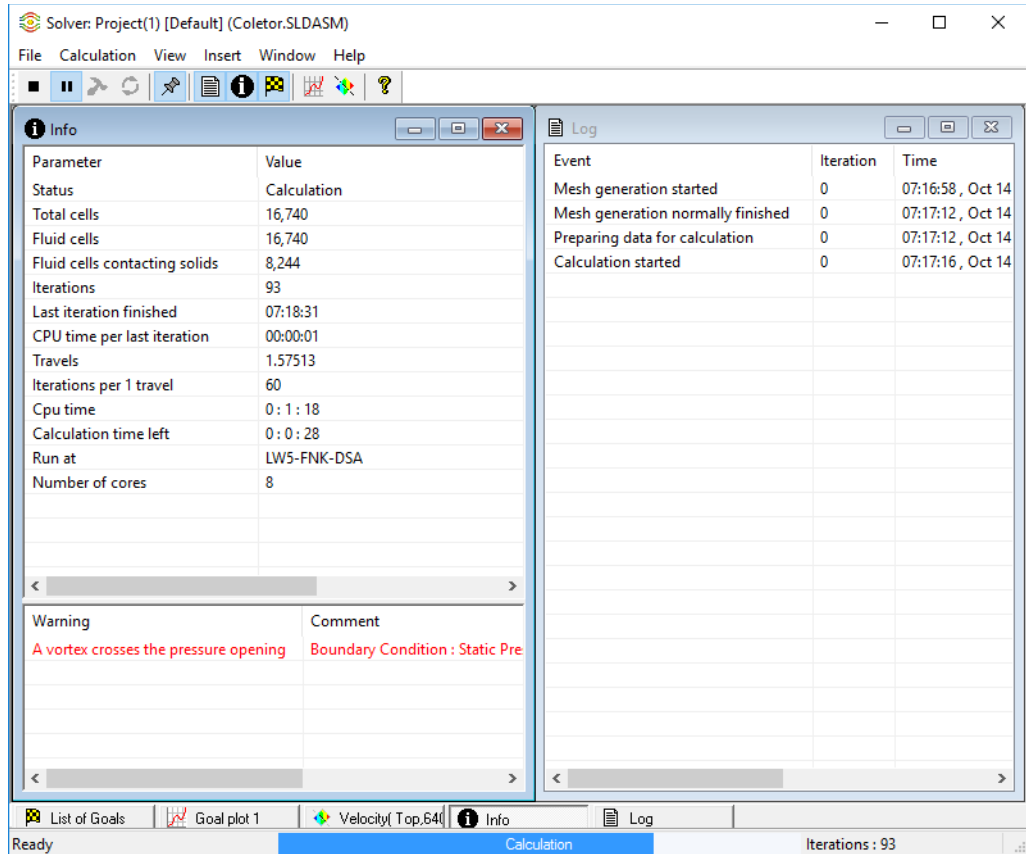

**Goal Plot Window**

The **Goal Plot** window will list each goal selected in the **Add/Remove Goals** window. Here you can see the current value and graph for each goal as well as the current progress towards completion given as a percentage. The progress value is only an estimate, and the rate of progress generally increases with time.

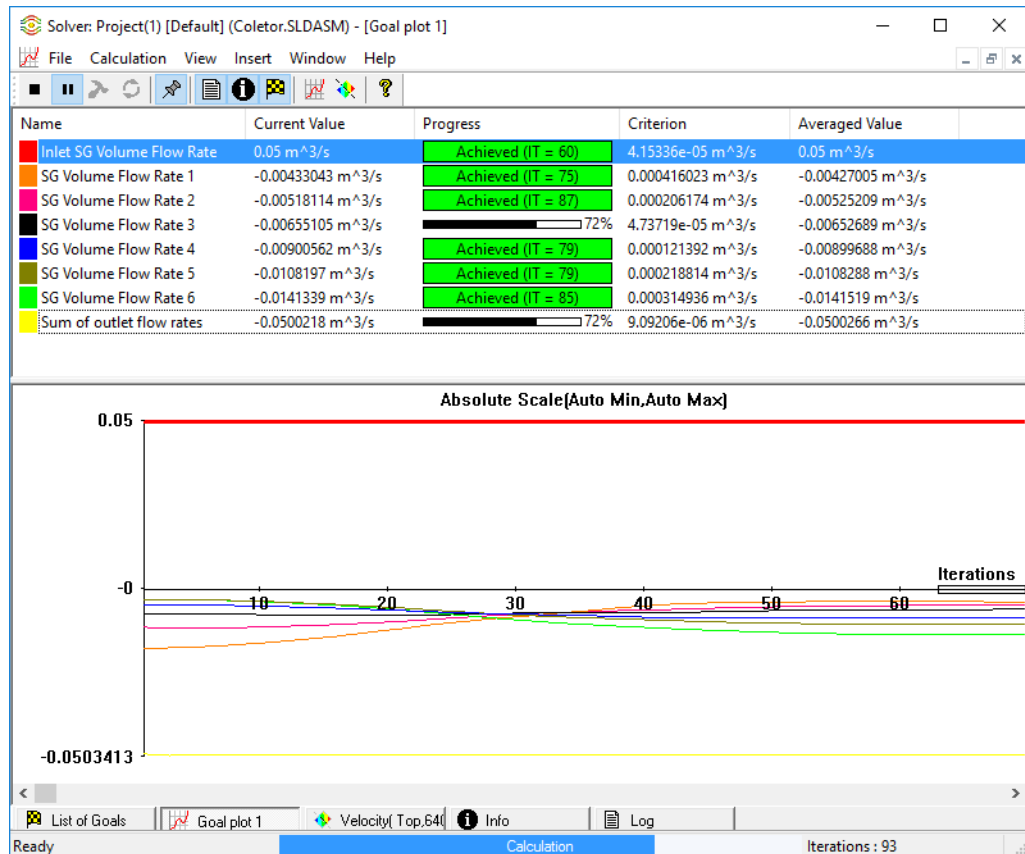
**Warning Messages**

Warning messages are also displayed in the **Info** section of the **Solver** window. In this analysis, you may see a warning message that reads “A vortex crosses the pressure opening”. This message indicates that there is a pressure difference across the outlet, which sometimes indicates a recirculation across the outlet. After running the analysis, the user can look at the result plots to see if the flow is entering through the outlets. This message is only a warning and can be ignored for this analysis, but if there was flow entering through the outlet, then the user would have to extend the outlet until the flow vectors were all leaving the outlet.

### 34 Solve the SOLIDWORKS Flow Simulation project.

In the SOLIDWORKS Flow Simulation analysis tree, right-click Project 1 and select **Run**.

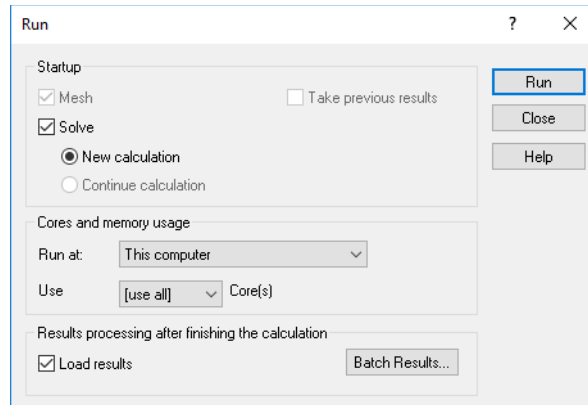

Make sure that the check boxes next to **Load Results** is selected.

Click **Run** with default settings.

The solver should take approximately 5 minutes to run.

#### Note

The Flow Simulation solver supports parallel computations. This allows you to select the number of CPUs to be used in the calculation.

### 35 Insert goal plot.

While the solver is running, In the Solver toolbar, click **Insert Goal Plot**  to open the **Add/Remove Goals** window.

Click the top checkbox to add all the goals you want to plot.

Click **OK**.

**36 Insert preview.**

With the solver running, after a few iterations, click the **Insert Preview** button  on the Solver toolbar.

In the **Preview Settings** window, selecting any SOLIDWORKS plane and clicking **OK** will create a preview plot of the solution on that plane. For this model, the Top Plane is a good choice to use as the preview plane. The preview plane can be chosen anytime from the SOLIDWORKS FeatureManager.

Click the **Settings** tab.

In the **Parameter** list, click **Velocity**.

Click **OK**.

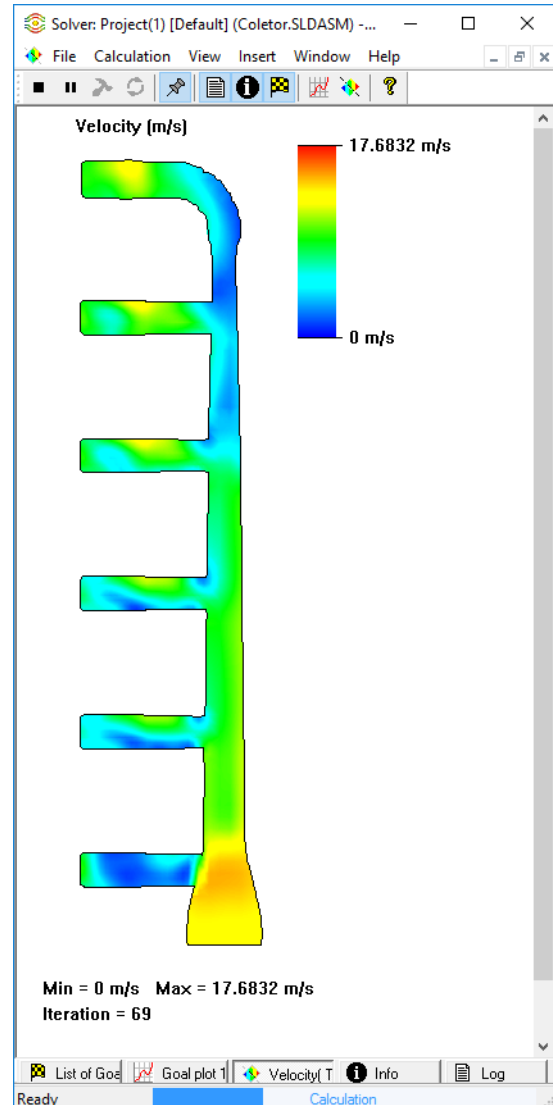
**Note**

The preview allows one to look at the results while the calculation is still running. This helps to determine if all the boundary conditions are correctly defined and gives the user an idea of how the solution will look even at an early stage. It is important to note that at the start of the run the results might look odd or change abruptly. However, as the run progresses, these changes will lessen and the results will settle in on a converged solution. The results can be displayed either in contour, isoline or vector representation.

**37 Close the Solver window.**

Click **File, Close**. This will close the **Solver** window.



## Post-processing

### Introducing: Cut Plots

The first step to view the results is to generate a transparent view of the geometry, a 'glass-body' image. This way, you can easily see where cut planes etc. are located with respect to the geometry.

A **Cut plot** displays any result on any SOLIDWORKS plane. The representation can be as a contour plot, as isolines, or as vectors and also in any combination of the above (e.g. contour with overlaid vectors).

### Where to Find It

- Shortcut Menu: Right-click **Cut Plots** under Results in the Flow Simulation analysis tree and click **Insert**
- CommandManager: **Flow Simulation > Insert > Cut Plot** 
- Menu: **Tools, Flow Simulation, Results, Insert, Cut Plot** 

---

### 38 Set model Transparency.

In the **Tools, Flow Simulation** menu, select **Results, Display, Transparency**.

Move the slider to the right to increase the **Value to set**. Set the model transparency to **0.75**.

Click **OK**.

### Tip

You can also right-click each part in the SOLIDWORKS FeatureManager tree and select **Change Transparency**.

### Note

As selected when initializing the solution, the results will be automatically loaded. The associated result file is indicated in the parentheses next to the Result folder.

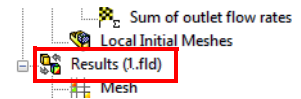

### 39 Create Cut Plots.

In the Flow Simulation analysis tree, right-click Cut Plots under Results and select **Insert**.

In the **Section Plane or Planar Face** box, select the Top plane view.

Click **OK**.

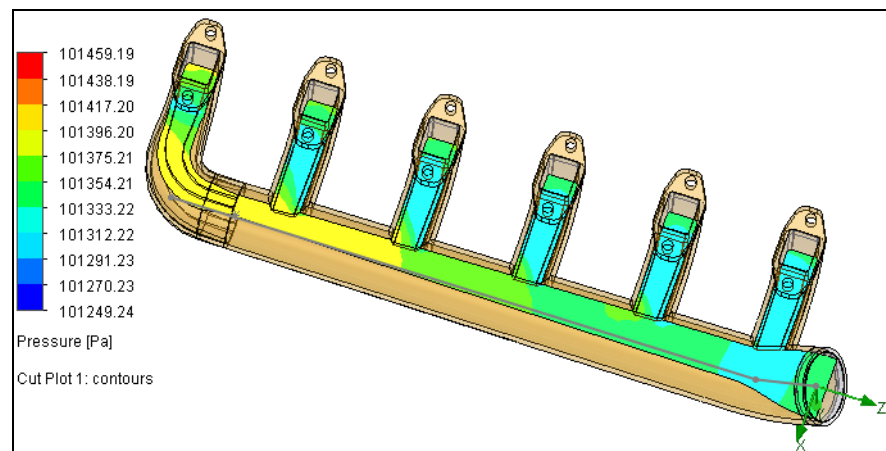

We can observe that the total pressure magnitude varies from 101,249 Pa to 101,459 Pa.

A Cut Plot 1 item will be created in the Flow Simulation analysis tree under the Cut Plots folder.

#### 40 Hide the cut plot.

Right-click the Cut Plot 1 icon and select **Hide**.

#### 41 Add a cut plot.

Right-click the Cut Plots icon under Results and select **Insert**.

Choose the Top Plane as the cut plane.

Make sure that the **Contours** button is selected.

Under **Contours** select **Velocity** and increase **Number of Levels** slider to **50**.

Click **OK**.

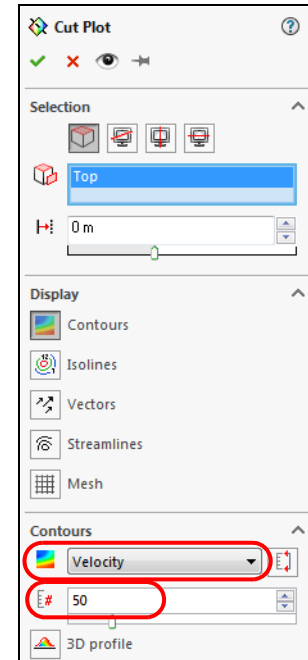

#### Note

The limits of the legend default to the global maximum and minimum. Use the **Adjust Maximum and Minimum** button under the **Contours** dialog to change them.

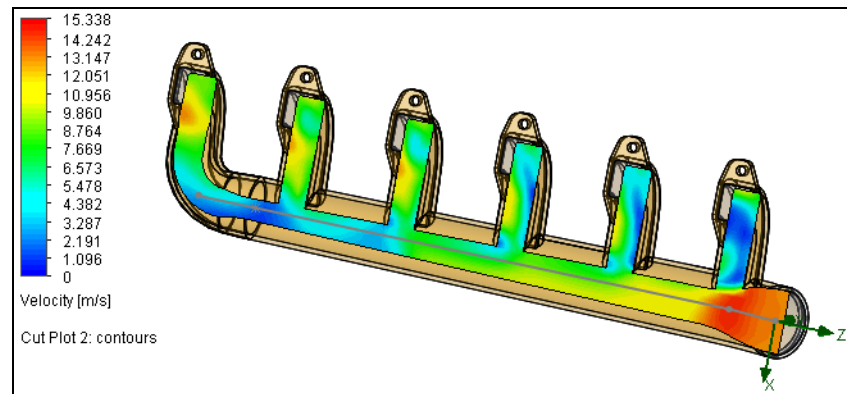

The maximum velocity close to 15.3 m/s is reached close to the inlet where the rapid narrowing of the profile ends.

To modify the options for this and other plots, either double-click on the color scale or right-click the plot name and select **Edit Definition**.

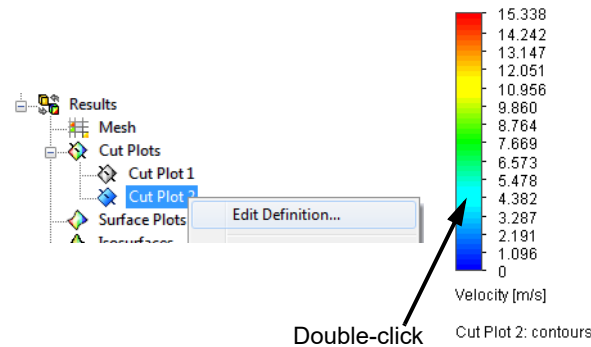

### Scaling the Limits of the Legend

Click directly on the lower or upper limit value in the legend. The desired limit value can then be entered in the text field.

To the right of the text field, there are two auto-scaling buttons. The first button (left side) auto-scales the maximum value of the legend to the maximum value existing in the model. The second button auto-scales the maximum value of the legend to the maximum value in that cut plane. These buttons also exist for adjusting the minimum values of the legend.

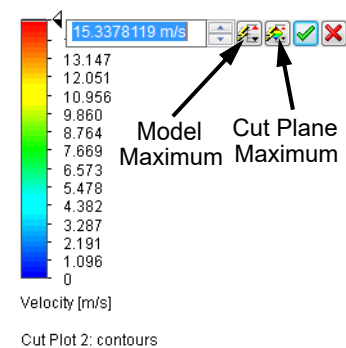

### Changing Legend Settings

To edit various legend settings such as color palette, out of range colors, font and its size and others, right click directly on the legend and use the **Edit** and **Appearance** commands.

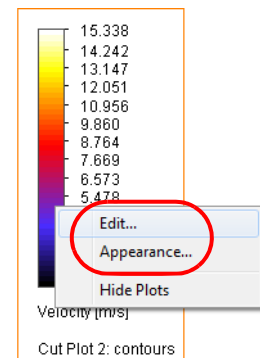

### Orientation of the Legend, Logarithmic Scale

Legend can be oriented vertically, or horizontally. To change the legend orientation, right-click the legend and click **Make Horizontal** (or **Make Vertical**).

Click **Logarithmic Scale** to change the axes to this scale.

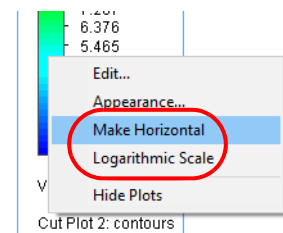

**42 Animate cut plot through the model.**

The animation feature can be used to view how the quantity plotted on the cut plot (total pressure in our example) varies through the model.

Right-click on the Cut Plot 2 item under the Cut Plots folder and select

**Play**, to automatically move the cutting plane (Top plane in our example) through the mode and view how the plotted quantity varies.

**Stop** the animation by clicking the stop button  in the right bottom corner of the screen.

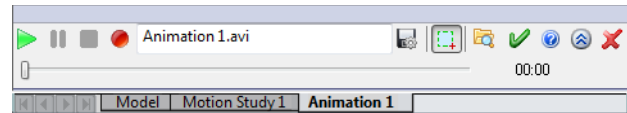
**43 Create vector cut plot.**

Right-click the Cut Plot 2 icon under Cut Plots and select **Edit Definition**.

Under **Display**, deselect **Contours** and click **Vectors**.

Click **OK**.

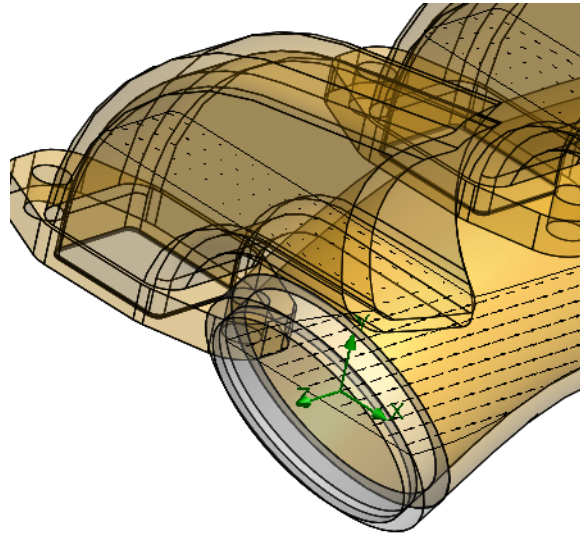
**Note**

The vector **Spacing**, their **Size**, and other vector parameters can be adjusted in the **Vectors** dialog of the **Cut Plot** window.

**44 Edit Cut Plot 2.**

Edit definition of Cut Plot 2. Change the offset distance to -0.02m. Click **OK**.

**Note**

The new position of the cut plot will be used later on in this lesson.



**45 Hide Cut Plot 2.**

Right-click the Cut Plot 2 icon under Results, Cut Plots in the SOLIDWORKS Flow Simulation analysis tree and select **Hide**.

## Introducing: Surface Plot

A **Surface Plot** displays any result on any SOLIDWORKS surface. The representation can be as a contour plot, as isolines, or as vectors - and also in any combination of the above (e.g. contour with overlaid vectors).

## Where to Find It

- Shortcut Menu: Right-click **Surface Plots** under Results in the Flow Simulation analysis tree and click **Insert**
- CommandManager: **Flow Simulation > Insert > Surface Plot** 
- Menu: **Tools, Flow Simulation, Results, Insert, Surface Plot** 

---

### 46 Create surface plot.

In the Flow Simulation analysis tree, right-click the Surface Plots icon under Results and select **Insert**.

Select **Use all faces**.

Make sure **Contours** is selected and specify **Pressure** as the quantity to plot.

Click **OK**.

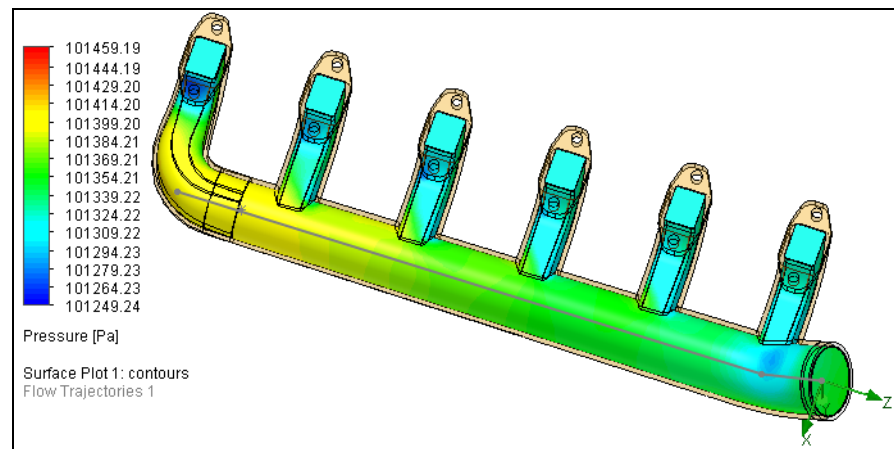

A Surface Plot 1 icon will be created in the SOLIDWORKS Flow Simulation analysis tree under Surface Plots. The same basic options are available for Surface Plots as for Cut Plots. Feel free to experiment with different combinations on your own.

**47 Probe.**

In the Flow Simulation analysis tree, right-click Results and select **Probe**. Select points of interest in the graphics window.

The pressure at those locations will appear in the graphics window.

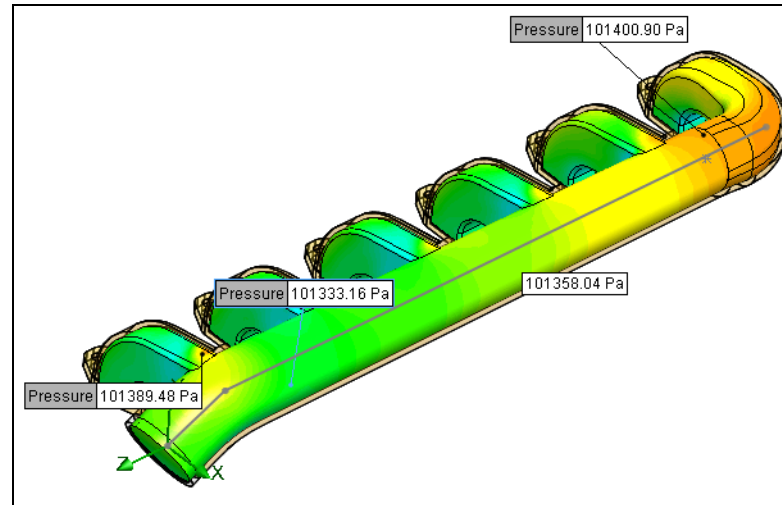

To turn the **Probe** tool off, right-click Results and select **Probe** again.

To turn off the probe displays, right-click Results and select **Display Probes**.

**48 Hide Surface Plot 1.**

Right-click the Surface Plot 1 and select **Hide**.

**Introducing: Flow Trajectories**

Using **Flow trajectories**, you can show the flow streamlines and paths of the massless particles that are inserted into the fluid. Flow trajectories provide a very good image of the 3D fluid flow. You can also see how parameters change along each trajectory by exporting data into Microsoft Excel. Additionally, you can save trajectories as SOLIDWORKS reference curves. The trajectories can also be colored by values of whatever variable chosen in the **View Settings** window.

**Where to Find It**

- Shortcut Menu: Right-click **Flow Trajectories** under Results in the Flow Simulation analysis tree and click **Insert**
- CommandManager: **Flow Simulation > Insert > Flow Trajectories** 
- Menu: **Tools, Flow Simulation, Results, Insert, Flow Trajectories**

#### 49 Create flow trajectory.

In the SOLIDWORKS Flow Simulation FeatureManager, right-click the Flow Trajectories icon under Results and select **Insert**.

Click the Flow Simulation analysis tree tab.

Under Boundary conditions, click **Static Pressure1** item. This will select the inner face of the outlet Lid 2 part as the origin for the trajectories.

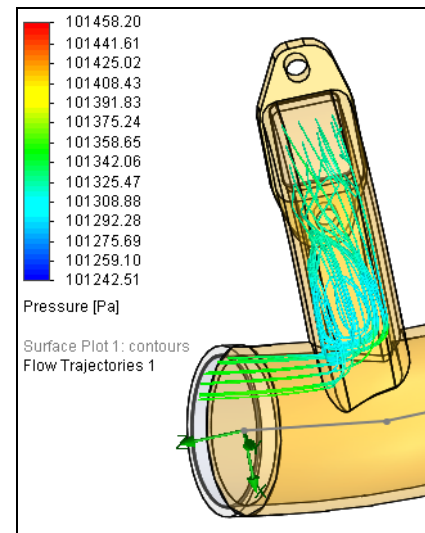

Under **Appearance** click the **Static Trajectories** , and set **Draw Trajectories As** to **Pipes**.

In the **Number of points** box, type 16.

Click **OK**.

#### Discussion

Notice the trajectories that are entering and exiting through the exit lid. This is the reason for the warning (A vortex crosses the pressure opening) during the solution process. When flow both enters and exits the same opening, the accuracy of the results will be affected. In a case such as this, one would typically add the next component to the model (such as a pipe extending the computational domain) so that the vortex does not occur at an opening.

Another approach to deal with this warning message could be to change the boundary condition at the pressure opening. We applied a static pressure boundary condition to each outlet face. This applies static pressure to both sides of the lid. In reality, we know that if the lid was extended, the flow would experience some amount of pressure difference. To account for this, we could have used an environment pressure boundary condition. The environment pressure boundary condition applies total pressure to the face of the lid where the flow enters the model and static pressure to the face of the lid where the flow leaves the model. This type of boundary condition will provide us with more reliable results than the static pressure condition.

**Introducing: XY Plots**

**XY-Plot** allows you to see how a parameter changes along a specified direction. To define the direction, you can use curves and sketches (2D and 3D sketches). The data are exported into an Excel workbook, where parameter charts and values are displayed. The charts are displayed in separate sheets and all values are displayed in the **Plot Data** sheet.

**Where to Find It**

- Shortcut Menu: Right-click **XY Plots** under Results in the Flow Simulation analysis tree and click **Insert**
- CommandManager: **Flow Simulation > Insert > XY Plots** 
- Menu: **Tools, Flow Simulation, Results, Insert, XY Plots**

**50 Hide Flow Trajectories 1.**

Right-click the Flow Trajectories 1 icon under Results, Flow Trajectories in the SOLIDWORKS Flow Simulation analysis tree and select **Hide**.

**51 Plot XY plot.**

We have already created a SOLIDWORKS sketch containing a line through the manifold. This sketch can be created after the analysis is finished. Take a look at Sketch-XY Plot in the SOLIDWORKS FeatureManager analysis tree.

In the SOLIDWORKS Flow Simulation analysis tree, under Results, right-click the XY Plots icon and select **Insert**.

Under **Parameters**, select **Pressure** and **Velocity**.

Under **Selection**, select Sketch-XY Plot from the SOLIDWORKS FeatureManager.

Leave all options as defaults and click **Show**.

The window with the graphs of the selected results will open on the bottom of the screen.

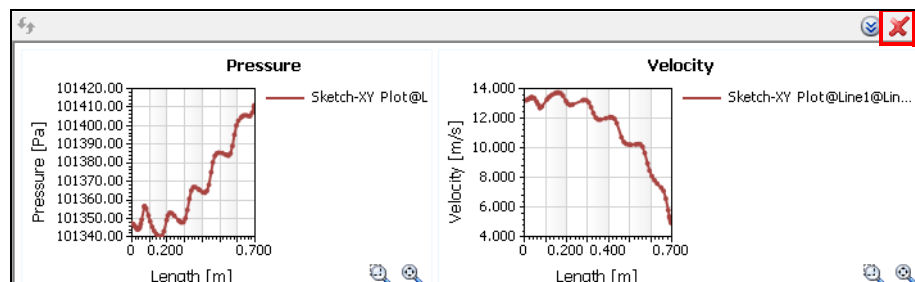

**Close** the plot window by clicking the close button (see the figure above).

Still in the **XY Plot** PropertyManager, click the **Export to Excel** button.

Microsoft Excel will open and generate two lists of data points as well as two graphs, one for **Velocity** and the other for **Pressure**. You will need to toggle between different sheets to view each graph.

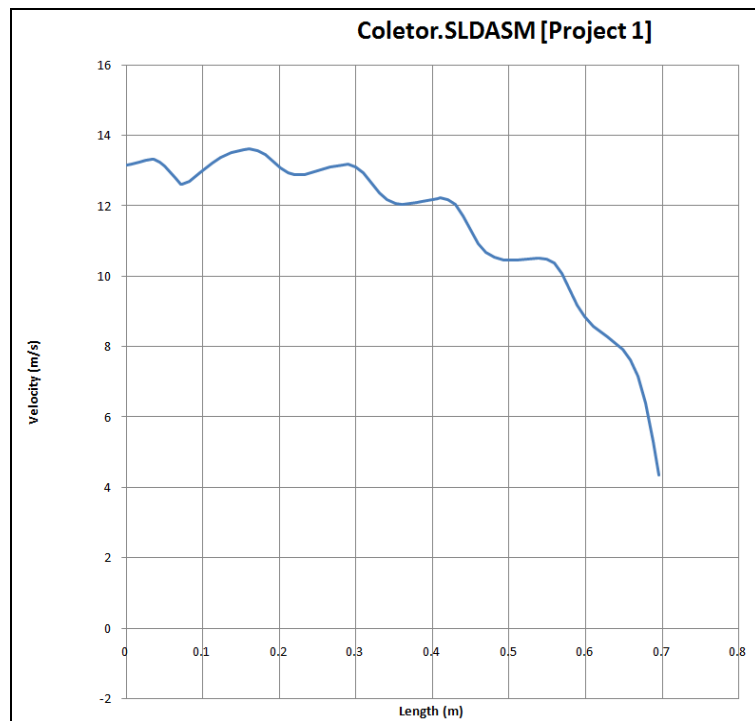
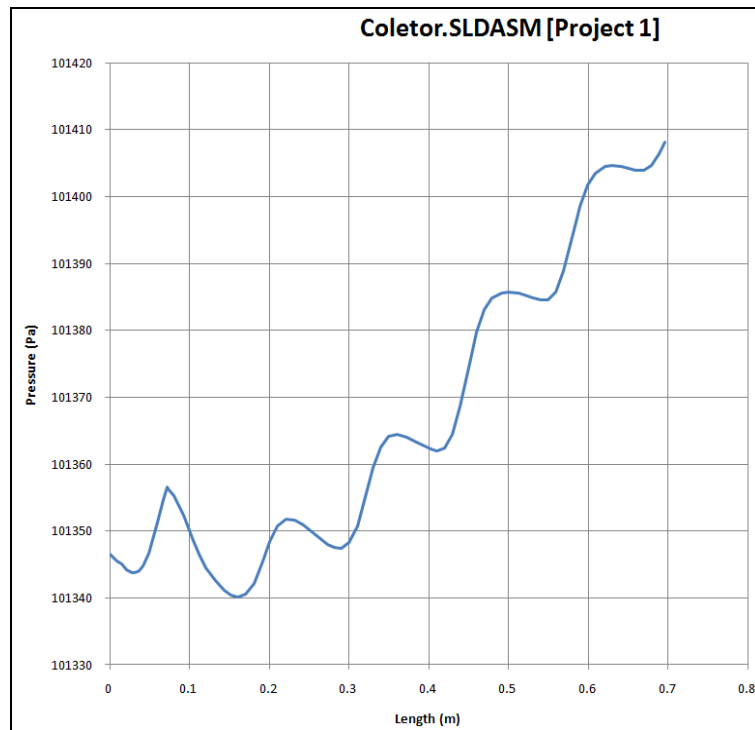

**Introducing: Surface Parameters**

Surface Parameters can be used to determine pressures, forces, heat flux as well as many other variables on any face within your model contacting the fluid. For this type of analysis, it would probably be of interest to calculate the average static pressure drop from the valve inlet to outlet. Surface parameters can also be calculated using section plane. If a section plane divides a model into several closed contours then surface parameters for each parameters can be calculated separately.

**Cut Plots** can be used to obtain **Surface Parameters**. This eliminates the need to create a dummy body to measure a fluid's integral parameters.

- Shortcut Menu: Right-click **Surface Parameters** under Results in the Flow Simulation analysis tree and click **Insert**
- CommandManager: **Flow Simulation > Insert > Surface Parameters** 
- Menu: **Tools, Flow Simulation, Results, Insert, Surface Parameters**

---

**52 Create Surface Parameters.**

In the SOLIDWORKS Flow Simulation analysis tree, under Results, right-click the Surface Parameters icon and select **Insert**.

In the SOLIDWORKS Flow Simulation analysis tree, under Boundary Conditions, click the Inlet Volume Flow 1 item. This will select and add the inner face of the inlet Lid 1 part to the **Faces** list.

Select **All** from the **Parameters** list.

Click **Show**. At the bottom of the screen, two tables will appear. The table on the left will contain the local parameters and the table to the right contains the integral parameters.

Shown in the **Local** table are the **Minimum, Maximum, Average,** and **Bulk Average** values for a number of parameters (including **Pressure, Temperature, Density,** etc.) for the inlet face. The same information can be obtained if the outlet lid faces were selected.

Close the two tabs by clicking the **Close Table** mark at the right hand side of the screen.

Click **Export to Excel**.

An Excel spreadsheet will be automatically created containing the values in the **Surface Parameter** window.

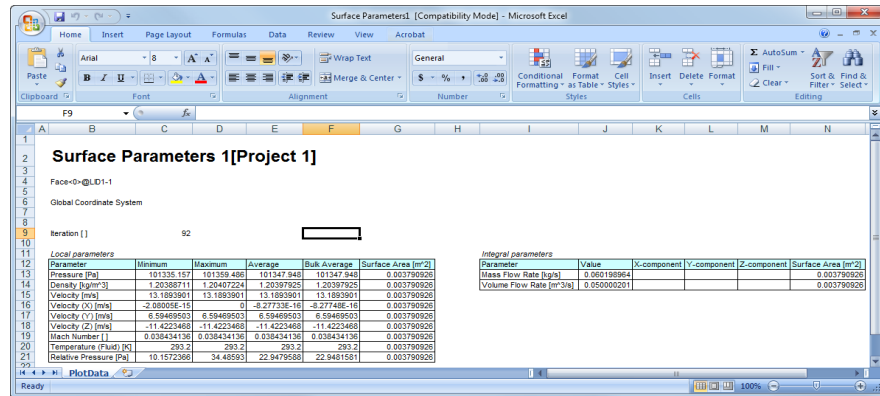

**Note**

The **Integral** table contains integrated values taken across the face of the selected surface. We can see that the volume flow rate on this inlet face is equal to the volume flow rate boundary condition of 0.05 m<sup>3</sup>/s that we specified.

**53 Calculate mass flow rate, volume flow rate and average pressure at each outlet.**

In the SOLIDWORKS Flow Simulation analysis tree, under Results, right-click the Surface Parameters icon and select **Insert**.

Under **Selection** select **Cut Plot**.

Select **Cut Plot 2** from the Cut Plot drop down.

Select **Separate** check box.

Under **Parameters**, select **Mass Flow Rate**, **Volume Flow Rate** and **Pressure**.

Click **Show**.

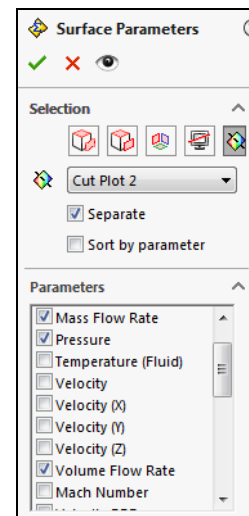

**Note**

Separate check box appears in the **Surface Parameters** PropertyManager when the section plane divides the model into several closed contours.

Under **Display Contours**, select items **Air(1)** to **Air(6)** corresponding to the six outlet ports locations.

Click **OK**.

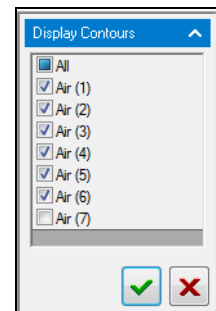

**Note**

Numbering of your **Air** items corresponding to the outlet ports may be different.

Flags of selected parameters for each contour are displayed in the graphics area.

Take a look at each parameter. Mass flow rate for each outlet is different.

There is smooth transition between Air (6) outlet and the main pipe. For that reason the mass and volume flow rates at Air (6) outlet is at their maximum.

On the other side, Air (1) outlet and the main pipe do not have smooth transition, and hence the mass and volume flow rates at Air (1) outlet are at their minimums.

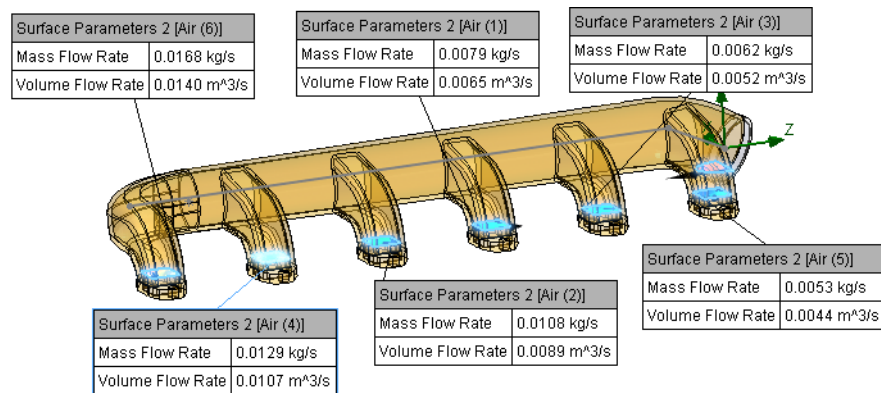

Click **OK**.

**Introducing: Goal Plot**

The goal plot allows you to see how the goal changes throughout the flow simulation as well as the final value of the goal at the end of the calculation.

**Where to Find It**

- Shortcut Menu: Right-click **Goal Plots** under Results in the Flow Simulation analysis tree and click **Insert**
- CommandManager: **Flow Simulation > Results > Goal Plot** 
- Menu: **Tools, Flow Simulation, Results, Goal Plot**

**54 Goals plot.**

In the SOLIDWORKS Flow Simulation analysis tree, under Results, right-click Goal Plots and select **Insert**.

Select **All Goals** in the **Goal Filter** and check **All** in the **Goals to Plot** list.

Under **Options** select **Group charts by parameter**.

Click **Show**.

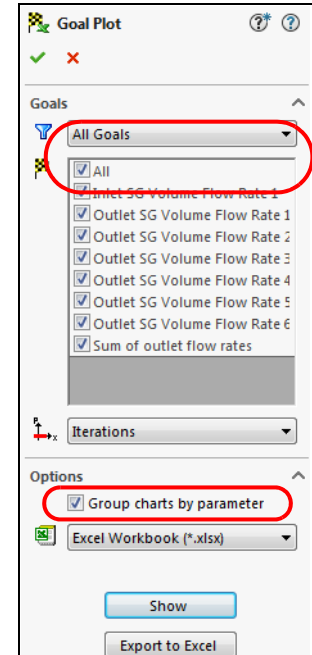

The table of the goal values will open on the bottom of the screen.

Goal Name	Unit	Value	Averaged	Minimum	Maximum	Progress [%]	Use In Cc	Delta	Criteria
Inlet SG Volume Flow Rate	[m <sup>3</sup> /s]	0.0500	0.0500	0.0500	0.0500	100	Yes	5.9958e-006	4.1536e-005
Outlet SG Volume Flow Rate 1	[m <sup>3</sup> /s]	-0.0047	-0.0047	-0.0047	-0.0047	100	Yes	4.8066e-005	0.0004
Outlet SG Volume Flow Rate 2	[m <sup>3</sup> /s]	-0.0050	-0.0050	-0.0051	-0.0050	100	Yes	0.0001	0.0002
Outlet SG Volume Flow Rate 3	[m <sup>3</sup> /s]	-0.0063	-0.0062	-0.0063	-0.0062	100	Yes	4.3822e-005	4.6039e-005
Outlet SG Volume Flow Rate 4	[m <sup>3</sup> /s]	-0.0093	-0.0093	-0.0093	-0.0093	100	Yes	1.4382e-005	0.0001
Outlet SG Volume Flow Rate 5	[m <sup>3</sup> /s]	-0.0107	-0.0107	-0.0107	-0.0106	100	Yes	4.0308e-005	0.0002
Outlet SG Volume Flow Rate 6	[m <sup>3</sup> /s]	-0.0141	-0.0141	-0.0141	-0.0141	100	Yes	3.8274e-005	0.0003
Sum of outlet flow rates	[m <sup>3</sup> /s]	-0.0500	-0.0500	-0.0500	-0.0500	100	Yes	6.0592e-006	9.1051e-006

Change the view from **Summary** to **History**.

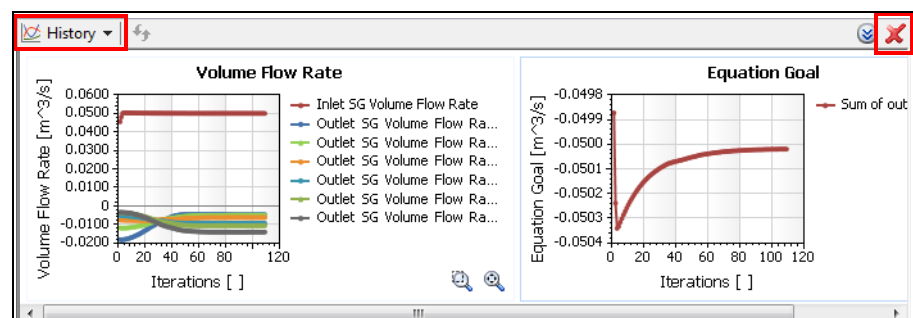

**Close** the goal plot window by clicking the close button (see the figure above).

Still in the **Goal Plot** PropertyManager, click the **Export to Excel** button.

An Excel spreadsheet will be automatically created containing information about the goals.

Goal Name	Unit	Value	Averaged Value	Minimum Value	Maximum Value
Inlet SG Volume Flow Rate	[m³/s]	0.050000201	0.050000197	0.0500001	0.050000268
Outlet SG Volume Flow Rate	[m³/s]	-0.014644803	-0.014617143	-0.014661311	-0.014528126
Outlet SG Volume Flow Rate	[m³/s]	-0.004634992	-0.004634391	-0.004671638	-0.004611926
Outlet SG Volume Flow Rate	[m³/s]	-0.010592901	-0.010582666	-0.01059644	-0.010565472
Outlet SG Volume Flow Rate	[m³/s]	-0.006565608	-0.006577662	-0.006595766	-0.006565204
Outlet SG Volume Flow Rate	[m³/s]	-0.005087456	-0.00510545	-0.00512596	-0.005087456
Outlet SG Volume Flow Rate	[m³/s]	-0.008492752	-0.008501136	-0.008539487	-0.008488165
Sum of outlet flow rates	[m³/s]	-0.050018513	-0.050018449	-0.050018661	-0.050018347

Iterations: 92  
Analysis interval: 27

**Close** the **Goal Plot** PropertyManager.

#### Note

The spreadsheet contains the final, maximum, minimum and averaged values of the goal during the calculation. In addition, there are plots showing how the goal changed during the calculation.

Negative values represent flow out of the computational domain.

Here, we can also verify that our inlet volume flow rate boundary condition was also applied properly during the calculation. In addition, the total flow out is equal to the total flow in.

#### Introducing: Save Image

Postprocessing images such as cut plots and surface plots can be exported in various image formats, and also in the eDrawings format.

#### Where to Find It

- Shortcut Menu: Right-click the Results folder and select **Save Image**
- CommandManager: **Flow Simulation > Screen Capture > Save Image**
- Menu: **Tools, Flow Simulation, Results, Screen Capture, Save Image**

### 55 Save image as eDrawings.

Show all your result plots.

Right-click on the Results folder and select **Save Image**.

Select **eDrawings** as the format, and keep the default name Project 1.easm.

Click **Save**.

The file will be saved in the directory associated with this project.

**Close** the PropertyManager.

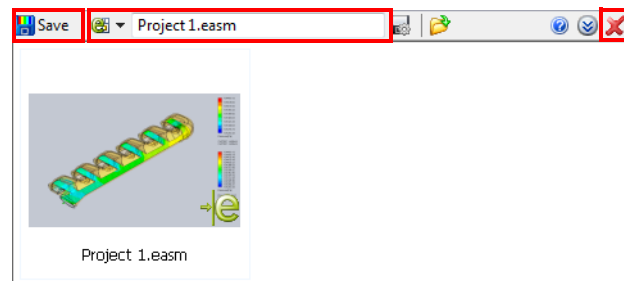

### 56 Open eDrawings file.

Navigate to the result folder associated with this project, and open Project 1.easm by double-clicking on it.

eDrawings will open the model with all defined results plots.

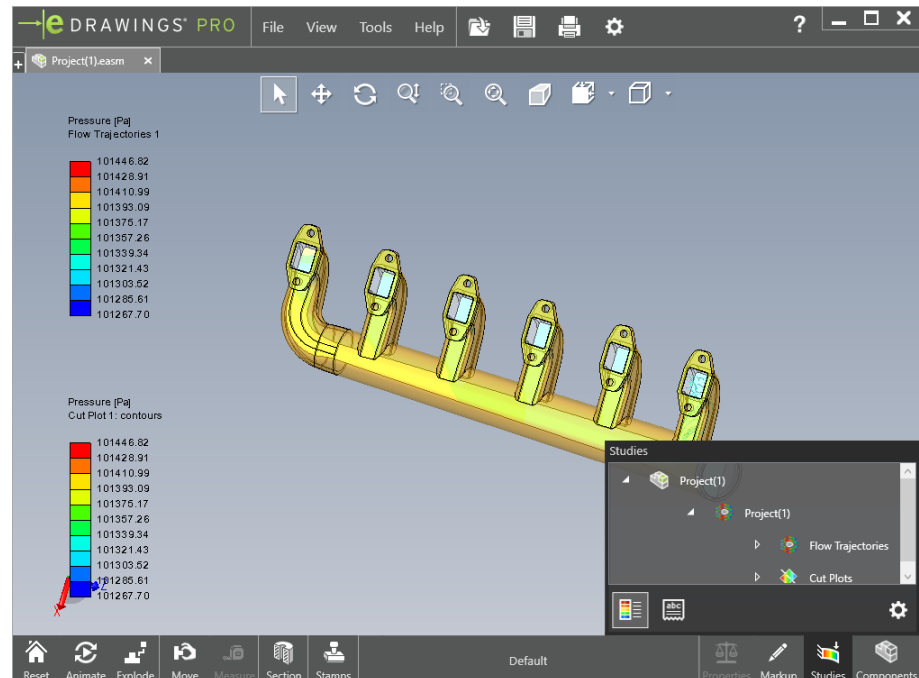

All plots shown in the Flow Simulation feature tree will be included.

**57 Save and Close.**

**Save** and **Close** the assembly.

---

**Discussion**

We specified an inlet volume flow rate of  $0.05 \text{ m}^3/\text{s}$  and have verified that this boundary condition was applied properly using **Surface Parameters** and **Goal Plots** that this value was applied.

Due to conservation of mass, we also know that the total volume flow rate into the manifold should equal the total volume flow rate out of the manifold. We can verify that this is true using the **Goal Plot** and looking at our goal for the Sum of outlet flow rates.

Furthermore, we would like to determine if the design of the manifold will result in efficient engine performance. In the beginning of the lesson, we said that the ideal situation would have similar flow through all of the outlet ports. When looking at our goals, we can see that the volume flow rate can vary significantly through the outlet ports. It is up to the engineer to decide whether design modification would be necessary to produce a more uniform outlet flow through each port.

**Summary**

In this lesson we learned how to set up a Flow Simulation project. The **Wizard** was used to create all of the general settings of the analysis. Both inlet and outlet boundary conditions were defined and a number of goals were created. The results of the simulation was thoroughly post-processed using many of the options available in SOLIDWORKS Flow Simulation. The stages of flow simulation that were outlined in this lesson will be followed throughout the book.

